

### GENERAL DESCRIPTION

OB3652x is primary side control offline LED lighting power switch with very low operation current which can achieve accurate LED current for an isolated lighting application in a single stage converter.

It significantly simplifies the LED lighting system design by eliminating the secondary side feedback components and the opto-coupler, and also the auxiliary winding inductance. A HV 600V power switch is also integrated into the device. The LED current can be adjusted externally by the sense resistor  $R_s$  at CS pin and high precision constant current regulation is realized.

OB3652x offers comprehensive protection coverage with auto-recovery features including open loop protection, short circuit protection, cycle-by-cycle current limiting, built-in leading edge blanking, VDD under voltage lockout (UVLO), latched over temperature protection (OTP), etc.

OB3652x is offered in SOP-8 or DIP8 packages.

### FEATURES

- High precision Constant Current Regulation at Universal AC input
- Primary-side Sensing and Regulation Without TL431 and Opto-coupler
- Sense and supply without auxiliary winding inductance
- Low System Cost and High Efficiency
- Low operation current
- Programmable CC Regulation
- Built-in Primary winding inductance compensation
- Built-in line compensation
- Short Circuit Protection
- Open Loop Protection
- Cycle-by-Cycle Current Limiting
- Built-in Leading Edge Blanking (LEB)
- VDD Under Voltage Lockout with Hysteresis
- Latched over temperature protection (OTP)

### APPLICATIONS

- LED lighting

### TYPICAL APPLICATION

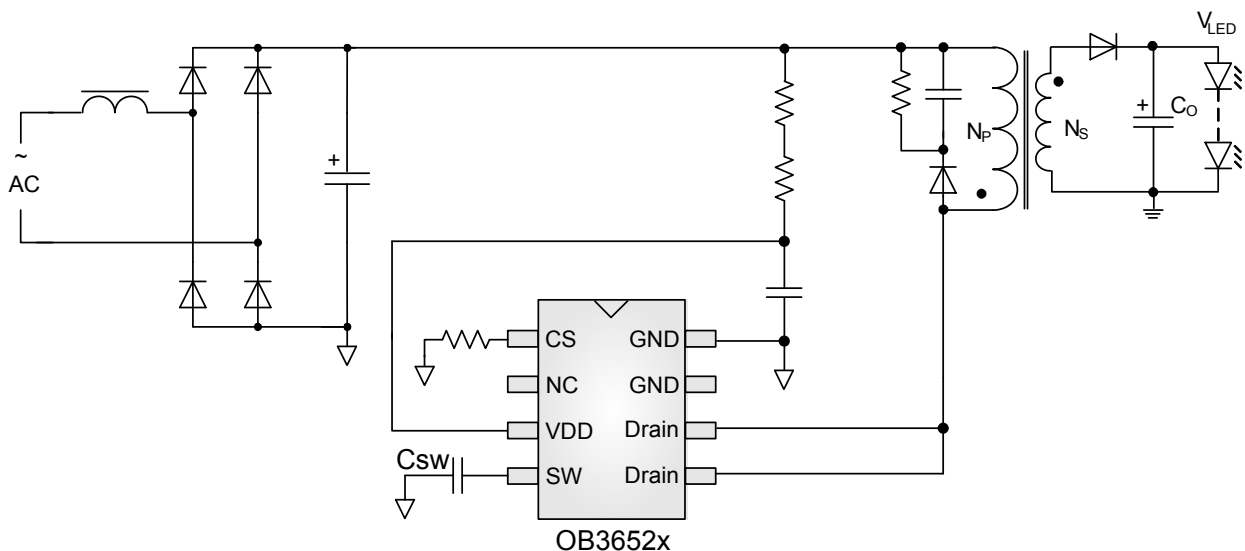

Note: The suggested range of  $C_{sw}$  is 47pF to 200pF.

**GENERAL INFORMATION**

**Pin Configuration**  
SOP-8

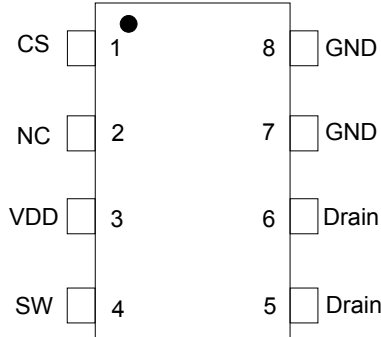

DIP-8

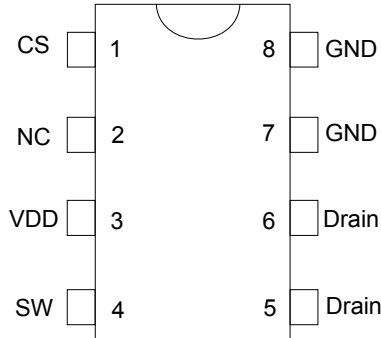

**Ordering Information**

| Part Number  | Description                     |
|--------------|---------------------------------|
| OB3652SCP-H  | 8 Pin SOP, Halogen-free in Tube |
| OB3652SCPA-H | 8 Pin SOP, Halogen-free in T&R  |
| OB3652MCP-H  | 8 Pin SOP, Halogen-free in Tube |
| OB3652MCPA-H | 8 Pin SOP, Halogen-free in T&R  |
| OB3652NAP    | 8 Pin DIP, Halogen-free in Tube |
| OB3652NCP    | 8 Pin SOP, Halogen-free in Tube |
| OB3652NCPA   | 8 Pin SOP, Halogen-free in T&R  |
| OB3652YCP    | 8 Pin SOP, Halogen-free in Tube |
| OB3652YCPA   | 8 Pin SOP, Halogen-free in T&R  |
| OB3652PAP    | 8 Pin DIP, Halogen-free in Tube |
| OB3652NCP-V  | 8 Pin SOP, Halogen-free in Tube |
| OB3652NCPA-V | 8 Pin SOP, Halogen-free in T&R  |
| OB3652PAP-H  | 8 Pin DIP, Halogen-free in Tube |

**Note:** All Devices are offered in Halogen-free Package if not otherwise noted.

**Package Dissipation Rating**

| Package | R $\theta$ JA (°C/W) |
|---------|----------------------|
| SOP-8   | 90                   |
| DIP-8   | 75                   |

**Recommended Operating Condition**

| Symbol | Parameter          | Range      |
|--------|--------------------|------------|
| VDD    | VDD Supply Voltage | 8 to 10.5V |

**Absolute Maximum Ratings**

| Parameter   | Value           |              |
|---|-----------------|--------------|
| VDD Voltage   | -0.3 to 20V     |              |
| DRAIN Voltage   | OB3652M/S/N/P-H | -0.3 to 650V |
|   | OB3652N/Y/P     | -0.3 to 600V |
|   | OB3652NCP-V     | -0.3 to 700V |
| CS Input Voltage                                      | -0.3 to 7V      |              |
| SW Input Voltage                                      | -0.3 to 20V     |              |
| Min/Max Operating Junction Temperature T <sub>J</sub> | -40 to 150 °C   |              |
| Operating Ambient Temperature T <sub>A</sub>          | -40 to 85 °C    |              |
| Min/Max Storage Temperature T <sub>stg</sub>          | -55 to 150 °C   |              |
| Lead Temperature (Soldering, 10secs)                  | 260 °C          |              |

**Note:** Stresses beyond those listed under "absolute maximum ratings" may cause permanent damage to the device. These are stress ratings only, functional operation of the device at these or any other conditions beyond those indicated under "recommended operating conditions" is not implied. Exposure to absolute maximum-rated conditions for extended periods may affect device reliability.

**Output Power Table**

| Product     | 90Vac~264Vac Input | 220Vac±20% Input |
|-------------|--------------------|------------------|
| OB3652SCP   | 3.1W               | 3.5W             |
| OB3652MCP   | 5.5W               | 5.8W             |
| OB3652NAP   | 9W                 | 13W              |
| OB3652NCP   | 6.7W               | 7.3W             |
| OB3652YCP   | 9W                 | 12W              |
| OB3652PAP   | 12.5W              | 18W              |
| OB3652NCP-V | 8W                 | 12W              |
| OB3652PAP-H | 12W                | 18W              |

**Notes:** Maximum practical continuous power in an open frame design with sufficient drain pattern as a heat sink, at 50°C ambient and 60°C temperature rise. Higher output power is possible with extra added heat sink or air circulation to reduce thermal resistance.

### Marking Information

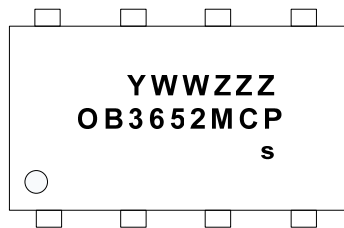
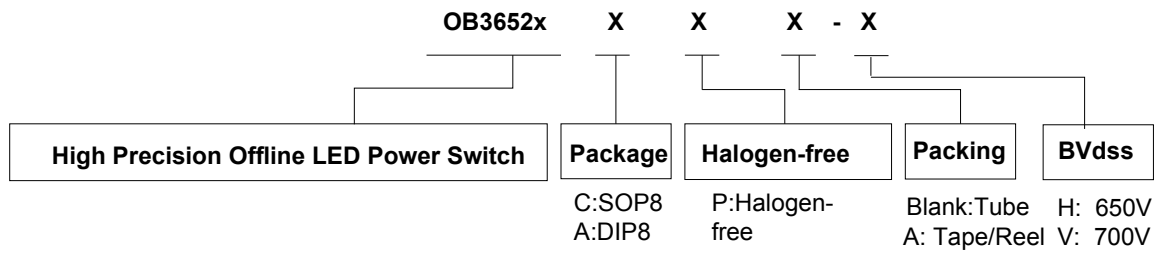

Y: Year Code  
 WW: Week Code (01-52)  
 ZZZ:Lot Code  
 C: SOP8  
 P:Halogen-free Package  
 S: Internal Code(Optional)

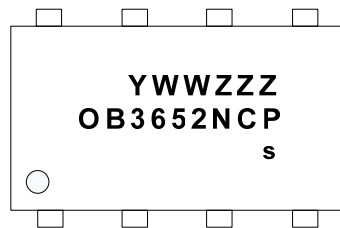

Y: Year Code  
 WW: Week Code (01-52)  
 ZZZ:Lot Code  
 C: SOP8  
 P:Halogen-free Package  
 S: Internal Code(Optional)

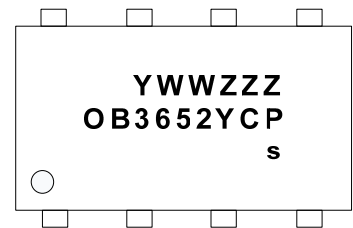

Y: Year Code  
 WW: Week Code (01-52)  
 ZZZ:Lot Code  
 C: SOP8  
 P:Halogen-free Package  
 S: Internal Code(Optional)

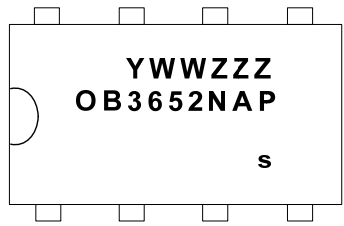

Y: Year Code  
 WW: Week Code (01-52)  
 ZZZ:Lot Code  
 A: DIP8  
 P:Halogen-free Package  
 s: Internal Code(Optional)

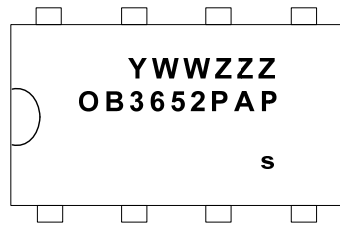

Y: Year Code  
 WW: Week Code (01-52)  
 ZZZ:Lot Code  
 A: DIP8  
 P:Halogen-free Package  
 s: Internal Code(Optional)

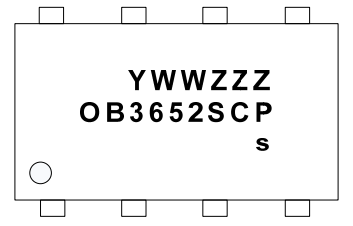

Y: Year Code  
 WW: Week Code (01-52)  
 ZZZ:Lot Code  
 C: SOP8  
 P:Halogen-free Package  
 S: Internal Code(Optional)

### TERMINAL ASSIGNMENTS

| Pin Num. | Pin Name | I/O | Description  |
|----------|----------|-----|--|
| 1        | CS       | I   | Current sensing terminal   |
| 2        | NC       |     | No Connection  |
| 3        | VDD      | P   | Power supply Input   |
| 4        | SW       | I   | MOSFET Source Terminal   |
| 5,6      | DRAIN    | I   | MOSFET Drain Terminal  |
| 7        | GND      | P   | Power Ground, suggest to be left floating with no pad in PCB layout. |

|   |     |   |              |
|---|-----|---|--------------|
| 8 | GND | P | Power Ground |
|---|-----|---|--------------|

## BLOCK DIAGRAM

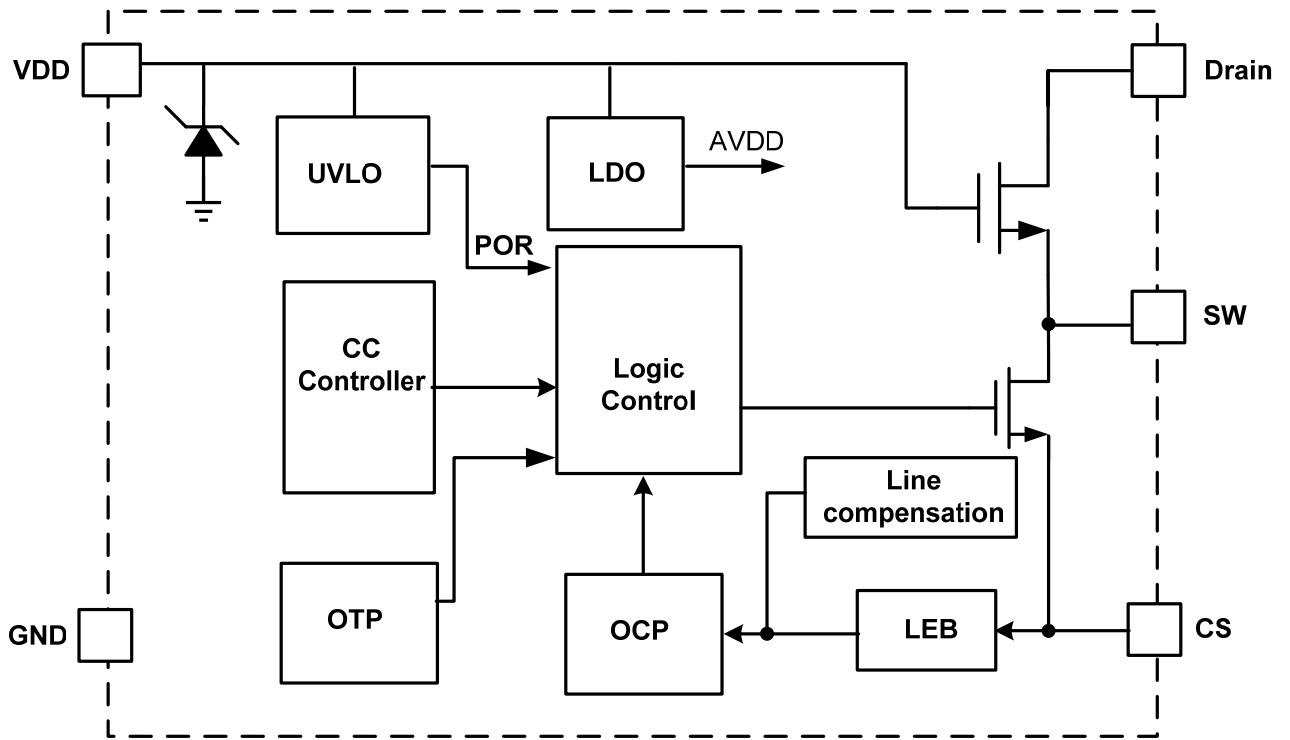

### ELECTRICAL CHARACTERISTICS

(TA = 25°C, VDD=7.5V, if not otherwise noted)

| Symbol                              | Parameter                       | Test Conditions                   | Min | Typ. | Max | Unit |
|-------------------------------------|---------------------------------|-----------------------------------|-----|------|-----|------|
| <b>Supply Voltage (VDD) Section</b> |                                 |                                   |     |      |     |      |
| I <sub>start-up</sub>               | Start up current                | VDD=UVLO(OFF)-1V                  |     | 100  | 150 | uA   |
| I <sub>op</sub>                     | Operation current               | VDD=7.5V, no loading              |     | 190  | 250 | uA   |
| UVLO(OFF)                           | VDD under voltage lockout exit  |                                   |     | 9    |     | V    |
| UVLO(ON)                            | VDD under voltage lockout enter |                                   |     | 6.5  |     | V    |
| VDD_CLAMP                           | VDD CLAMP                       | VDD current 1mA                   |     | 10.5 |     | V    |
| <b>Current Sense Input Section</b>  |                                 |                                   |     |      |     |      |
| TLEB                                | LEB time                        |                                   |     | 0.3  |     | us   |
| Vth_ocp                             | Over current threshold          |                                   | 485 | 500  | 515 | mV   |
| Td_oc                               | OCP propagation delay           | From OCP comparator to gate drive |     | 100  |     | ns   |
| Toff_max                            | Maximum off time                |                                   |     | 600  |     | us   |
| Toff_min                            | Minimum off time                |                                   |     | 5.5  |     | us   |
| Ton_max                             | Maximum on time                 |                                   |     | 75   |     | us   |
| <b>OTP Section</b>                  |                                 |                                   |     |      |     |      |
| OTP                                 | Over temperature protection     |                                   |     | 150  |     | °C   |

| Parameter<br>Product | BVdss(V)<br>MOSFET Drain-Source Breakdown Voltage |      |     |
|----------------------|---|------|-----|
|                      | Min   | Typ. | Max |
| OB3652SCP            | 650   |      |     |
| OB3652MCP            | 650   |      |     |
| OB3652NAP            | 600   |      |     |
| OB3652NCP            | 600   |      |     |
| OB3652YCP            | 600   |      |     |
| OB3652PAP            | 600   |      |     |
| OB3652NCP-V          | 700   |      |     |
| OB3652PAP-H          | 650   |      |     |

**CHARACTERIZATION PLOTS**

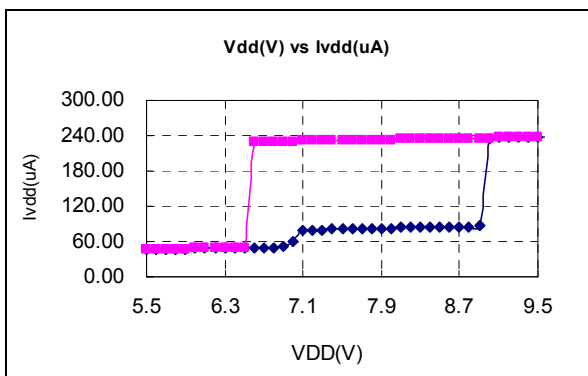
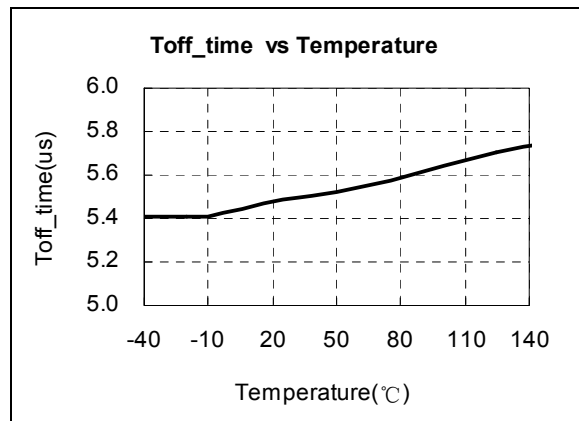
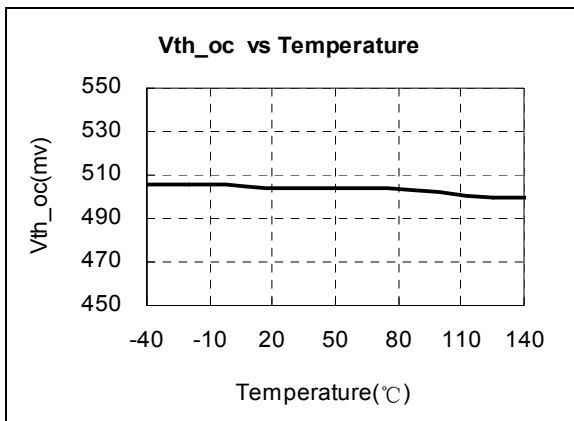
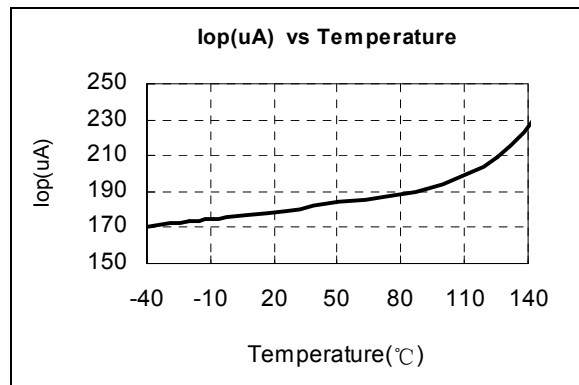
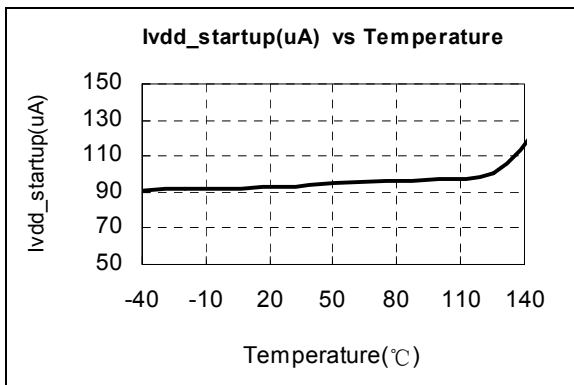
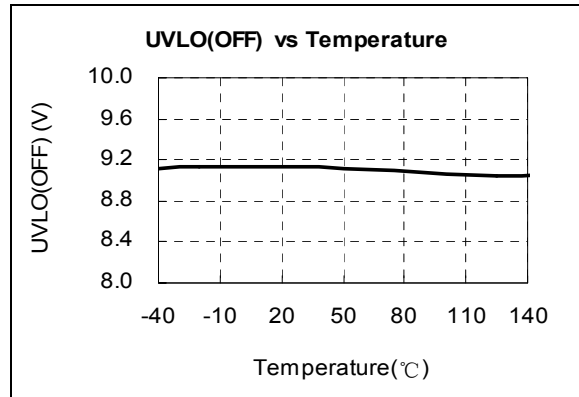
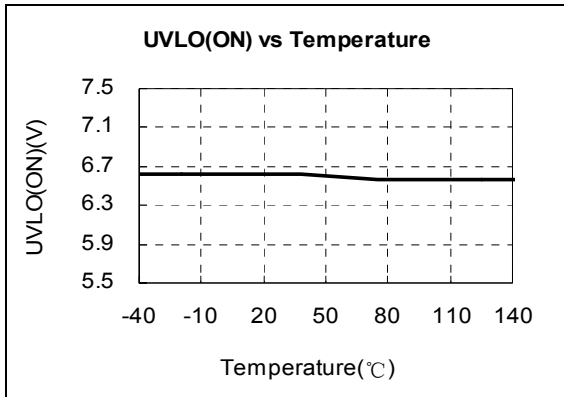

### OPERATION DESCRIPTION

OB3652x is a primary side control offline LED lighting controller with very low operation current which can achieve accurate LED current for an isolated lighting application in a single stage converter. It significantly simplifies the LED lighting system design by eliminating the secondary side feedback components and the opto-coupler, and also the auxiliary winding inductance. A HV 600V power switch is also integrated into the device.

- **Start up Control**

Startup process is realized by charging VDD capacitor. When VDD voltage reaches up to UVLO(OFF), the inner circuit works. An 10.5V (typical) clamp circuit is designed to clamp VDD voltage. At work state, no auxiliary winding inductance is necessary.

- **Adjustable CC point**

In OB3652x, the CC point can be externally adjusted by external current sense resistor  $R_s$  at CS pin as illustrated in typical application diagram. The larger  $R_s$  is, the smaller CC point is, and vice versa.

- **Principle of CC Operation**

For flyback operating in DCM, the output current  $I_{out}$  is given by

$$I_{out} = \frac{1}{2} L_p F_{sw} I_p^2 \eta / V_{out} \quad (1)$$

Where  $L_p$  indicates the inductance of primary winding and  $I_p$  is the peak current of primary winding.

Refer to the equation 1, the change of the primary winding inductance results in the change of the constant output current. To compensate the change from variations of primary winding inductance, the switching frequency is locked by an internal loop such that the switching frequency is

$$F_{sw} = \frac{1}{2T_{Demag}} \quad (2)$$

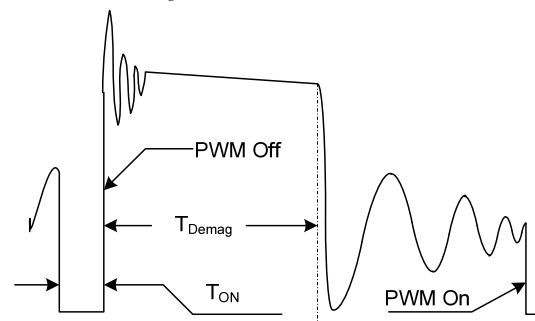

Figure.1 Drain voltage waveform

Since  $T_{Demag}$  is inversely proportional to the inductance, as a result, the product  $L_p$  and  $f_{sw}$  is constant, thus output current will not change as primary winding inductance changes. Up to  $\pm 10\%$  variation of the primary winding inductance can be compensated.

The output LED current is

$$I_{out} = \frac{1}{4} N \frac{V_{thoc}}{R_s} \quad (3)$$

Where  $N$  is the ratio of transformer between primary-side winding and secondary winding.

- **Current Sensing and Leading Edge Blanking**

Cycle-by-Cycle current limiting is offered in OB3652x. The switch current is detected by a sense resistor into the CS pin. An internal leading edge blanking circuit chops off the sensed voltage spike at initial power MOSFET on state.

- **Latched Over Temperature Protection**

Over temperature protection is offered in OB3652x. When temperature of the device rises over  $150^\circ\text{C}$  (typical), the switching frequency will decrease to half. And the state will be kept until the device restarts.

**PACKAGE MECHANICAL DATA**

**SOP8 PACKAGE OUTLINE DIMENSIONS**

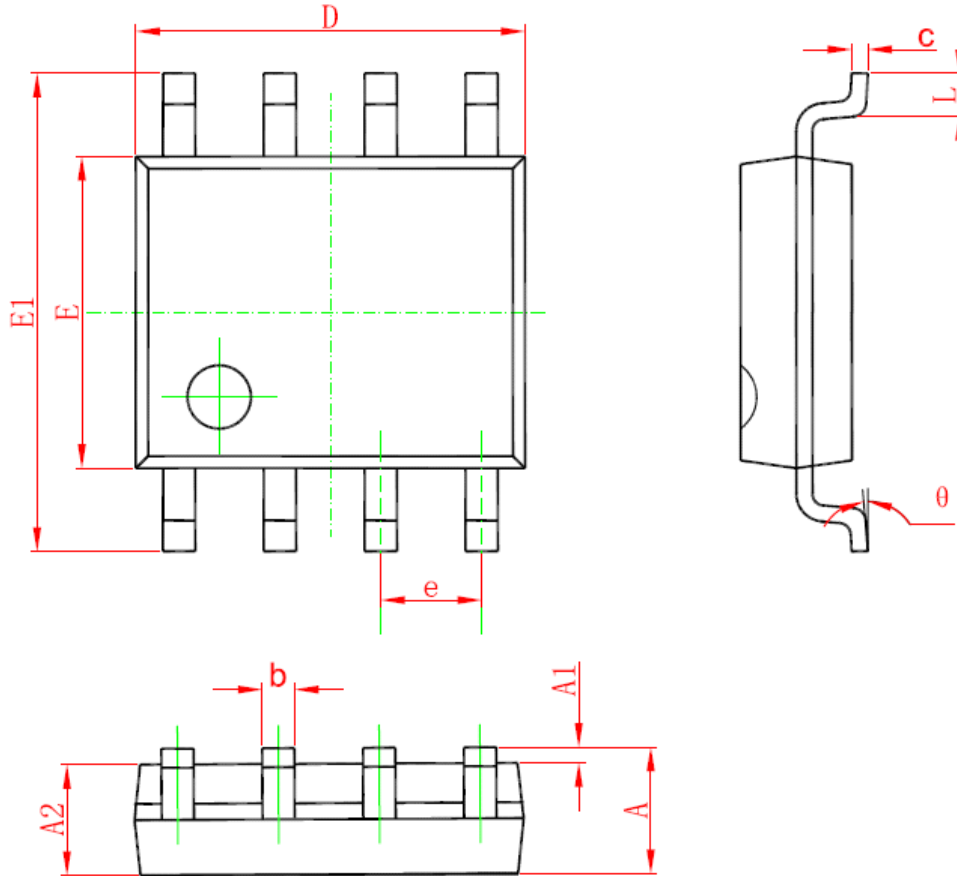

| Symbol | Dimensions In Millimeters |       | Dimensions In Inches |       |
|--------|---------------------------|-------|----------------------|-------|
|        | Min                       | Max   | Min                  | Max   |
| A      | 1.350                     | 1.750 | 0.053                | 0.069 |
| A1     | 0.050                     | 0.250 | 0.002                | 0.010 |
| A2     | 1.250                     | 1.650 | 0.049                | 0.065 |
| b      | 0.310                     | 0.510 | 0.012                | 0.020 |
| c      | 0.100                     | 0.250 | 0.004                | 0.010 |
| D      | 4.700                     | 5.150 | 0.185                | 0.203 |
| E      | 3.800                     | 4.000 | 0.150                | 0.157 |
| E1     | 5.800                     | 6.200 | 0.228                | 0.244 |
| e      | 1.270 (BSC)               |       | 0.050 (BSC)          |       |
| L      | 0.400                     | 1.270 | 0.016                | 0.050 |
| θ      | 0°                        | 8°    | 0°                   | 8°    |



**DIP8 PACKAGE OUTLINE DIMENSIONS**

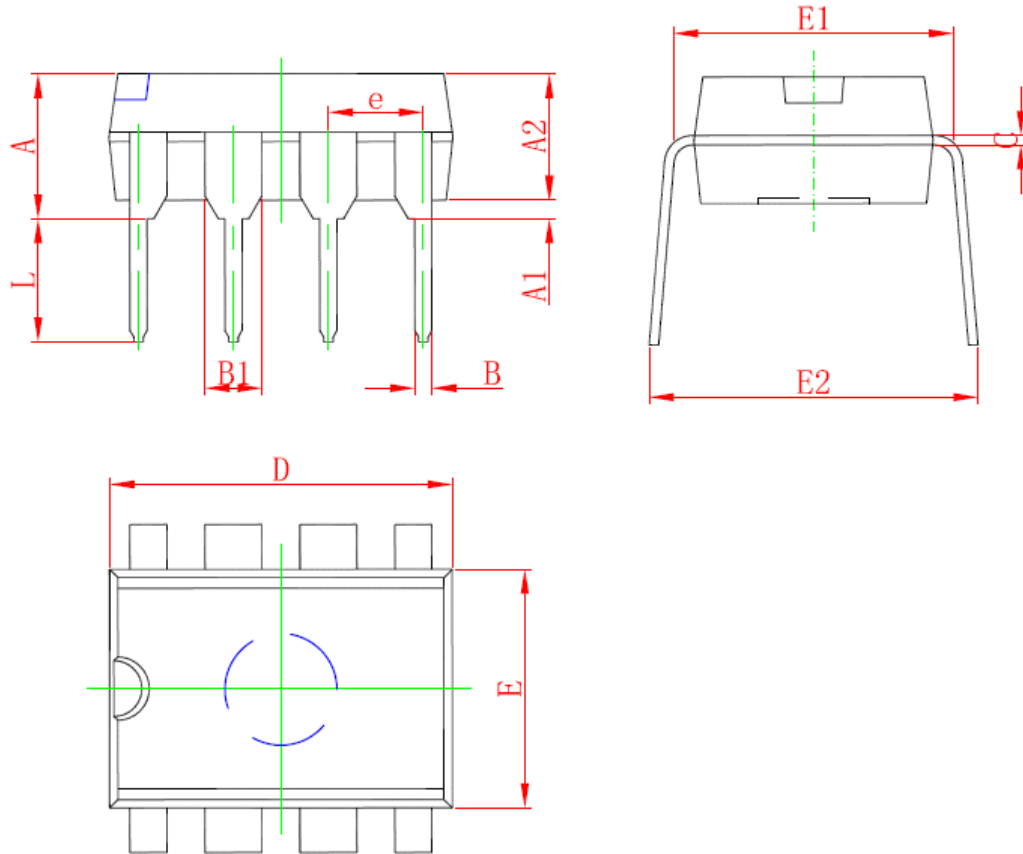

| Symbol | Dimensions In Millimeters |        | Dimensions In Inches |       |
|--------|---------------------------|--------|----------------------|-------|
|        | Min                       | Max    | Min                  | Max   |
| A      | 3.710                     | 5.334  | 0.146                | 0.210 |
| A1     | 0.381                     |        | 0.015                |       |
| A2     | 2.921                     | 4.953  | 0.115                | 0.195 |
| B      | 0.350                     | 0.650  | 0.014                | 0.026 |
| B1     | 1.524 (BSC)               |        | 0.06 (BSC)           |       |
| C      | 0.200                     | 0.360  | 0.008                | 0.014 |
| D      | 9.000                     | 10.160 | 0.354                | 0.400 |
| E      | 6.096                     | 7.112  | 0.240                | 0.280 |
| E1     | 7.320                     | 8.255  | 0.288                | 0.325 |
| e      | 2.540 (BSC)               |        | 0.1 (BSC)            |       |
| L      | 2.921                     | 3.810  | 0.115                | 0.150 |
| E2     | 7.620                     | 10.920 | 0.300                | 0.430 |

## **IMPORTANT NOTICE**

### **RIGHT TO MAKE CHANGES**

On-Bright Electronics Corp. reserves the right to make corrections, modifications, enhancements, improvements and other changes to its products and services at any time and to discontinue any product or service without notice. Customers should obtain the latest relevant information before placing orders and should verify that such information is current and complete.

### **WARRANTY INFORMATION**

On-Bright Electronics Corp. warrants performance of its hardware products to the specifications applicable at the time of sale in accordance with its standard warranty. Testing and other quality control techniques are used to the extent it deems necessary to support this warranty. Except where mandated by government requirements, testing of all parameters of each product is not necessarily performed.

On-Bright Electronics Corp. assumes no liability for application assistance or customer product design. Customers are responsible for their products and applications using On-Bright's components, data sheet and application notes. To minimize the risks associated with customer products and applications, customers should provide adequate design and operating safeguards.

### **LIFE SUPPORT**

On-Bright Electronics Corp.'s products are not designed to be used as components in devices intended to support or sustain human life. On-bright Electronics Corp. will not be held liable for any damages or claims resulting from the use of its products in medical applications.

### **MILITARY**

On-Bright Electronics Corp.'s products are not designed for use in military applications. On-Bright Electronics Corp. will not be held liable for any damages or claims resulting from the use of its products in military applications.