

## GENERAL DESCRIPTION

OB3635Bx is an offline LED lighting controller with high power factor, low THD and high constant current (CC) precision. It can achieve low system cost for an isolated lighting application by primary side control in a single stage converter. It significantly simplifies the LED lighting system design by eliminating auxiliary winding.

The proprietary CC control scheme is used and the system can achieve high power factor with constant on-time control scheme. Quasi-resonant (QR) operation and clamping frequency greatly improves the system efficiency. The advanced start-up technology is used to meet the start-up time requirement (<0.5s). The constant output current is compensated for tolerance of transformer inductance variation. And the line compensation and load compensation are built in OB3635Bx for high precisely constant output current control.

OB3635Bx offers comprehensive protection coverage with auto-recovery features including LED open loop protection, LED short circuit protection, cycle-by-cycle current limiting, built-in leading edge blanking, VDD under voltage lockout (UVLO), etc.

OB3635Bx is offered in SOP8/DIP8 package.

## FEATURES

- High PF (>0.95)
- Low THD (<10%)
- High precision constant current regulation at universal AC input
- Fast start-up (<0.5s)
- Primary-side sensing and regulation without auxiliary winding
- Low system cost and high efficiency
- Quasi-resonant operation
- Programmable CC regulation
- Built-in primary winding inductance compensation
- Built-in line compensation
- Built-in load compensation
- LED short circuit protection
- LED open loop protection
- Cycle-by-cycle current limiting
- Built-in leading edge blanking (LEB)
- VDD under voltage lockout with hysteresis
- Over temperature protection (OTP)
- Thermal fold-back control

## APPLICATIONS

- LED lighting

## TYPICAL APPLICATION

### Application Schematic 1:

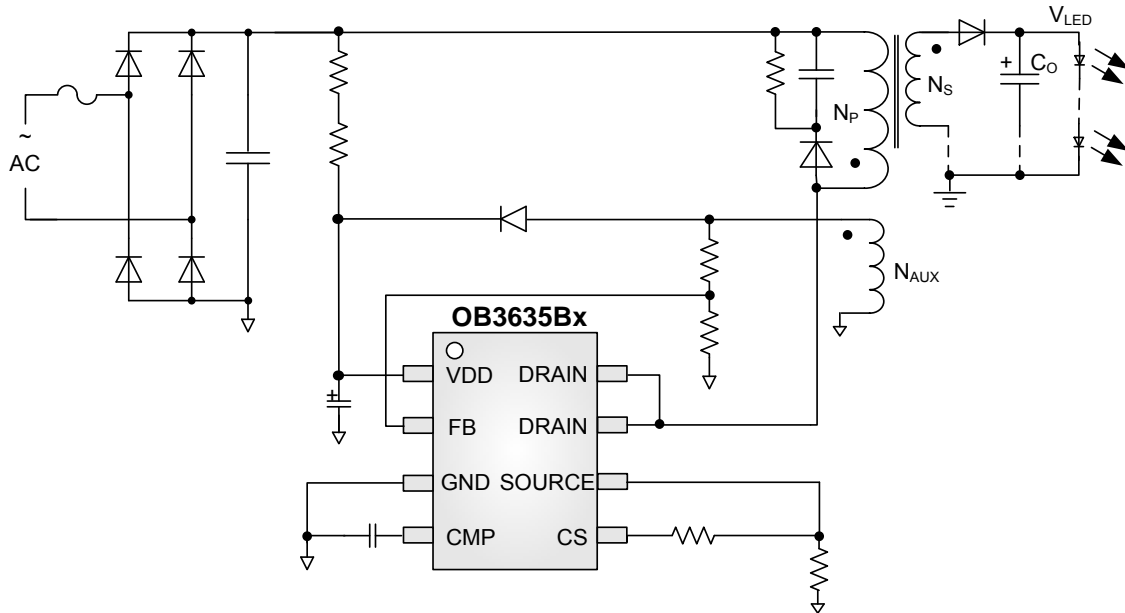

### Application Schematic 2:

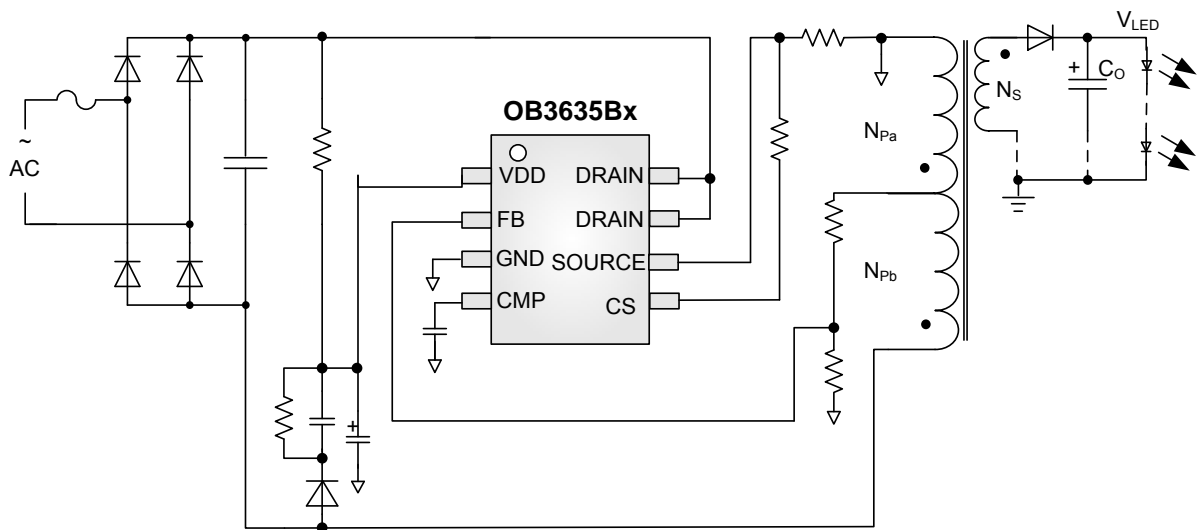

### GENERAL INFORMATION

#### Pin Configuration

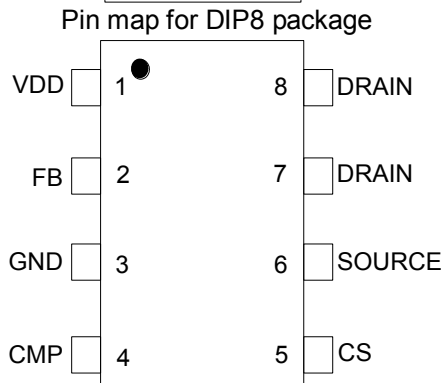
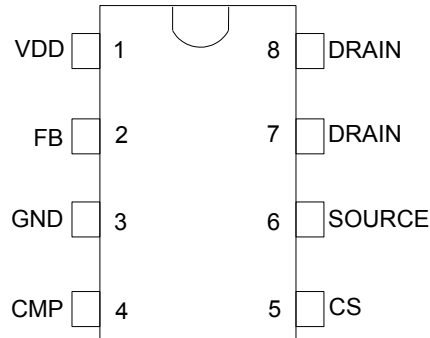

#### Ordering Information

Part Number	Description
OB3635BTAP-H	DIP8, Halogen-free in Tube
OB3635BNCP-H	SOP8, Halogen-free in Tube
OB3635BNCPA-H	SOP8, Halogen-free in T&R
OB3635BRCP-H	SOP8, Halogen-free in Tube
OB3635BRCPA-H	SOP8, Halogen-free in T&R
OB3635BVAP-H	DIP8, Halogen-free in Tube
OB3635BUAP-H	DIP8, Halogen-free in Tube
OB3635BRCP	SOP8, Halogen-free in Tube
OB3635BRCPA	SOP8, Halogen-free in T&R

**Note:** All Devices are offered in Halogen-free Package if not otherwise noted.

#### Package Dissipation Rating

Package	R $\theta$ JA (°C/W)
DIP8	75°C/W
SOP8	90°C/W

#### Absolute Maximum Ratings

Parameter	Value
Drain Voltage(off state)	-0.3 to 650V
VDD Voltage	-0.3 to 40V
SOURCE Voltage	-0.3 to 7V
CS Input Voltage	-0.3 to 7V
FB Input Voltage	-0.3 to 7V
COMP Voltage	-0.3 to 7V
Min/Max Operating Junction Temperature T <sub>J</sub>	-40 to 150 °C
Min/Max Storage Temperature T <sub>stg</sub>	-55 to 150 °C
Lead Temperature (Soldering, 10secs)	260 °C

**Note:** Stresses beyond those listed under "absolute maximum ratings" may cause permanent damage to the device. These are stress ratings only, functional operation of the device at these or any other conditions beyond those indicated under "recommended operating conditions" is not implied. Exposure to absolute maximum-rated conditions for extended periods may affect device reliability.

#### Output Power Table

Product	90-264VAC	220Vac±20%
	Open Frame	Open Frame
OB3635BTAP-H	18W	29W
OB3635BNCPA-H	7.5W	13.4W
OB3635BRCPA-H	10.4W	17.5W
OB3635BUAP-H	22.8W	38.4W
OB3635BVAP-H	24.1W	42.6W
OB3635BRCP	11W	17.5W

**Notes:** Maximum practical continuous power in an open frame design with sufficient drain pattern as a heat sink, at 50°C ambient and 60°C temperature rise. Higher output power is possible with extra added heat sink or air circulation to reduce thermal resistance.

### Marking Information

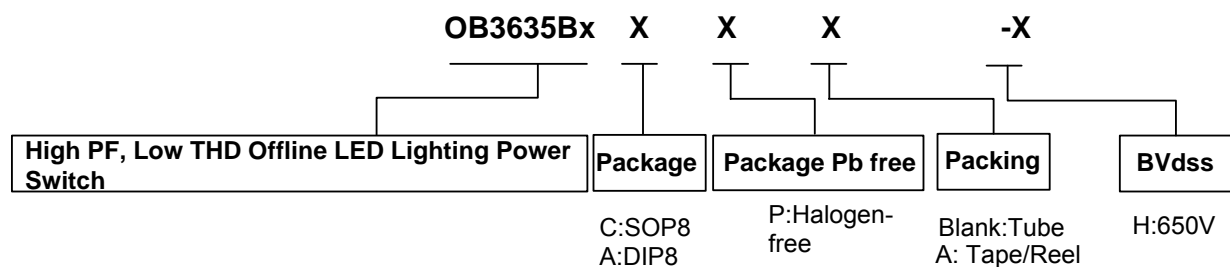

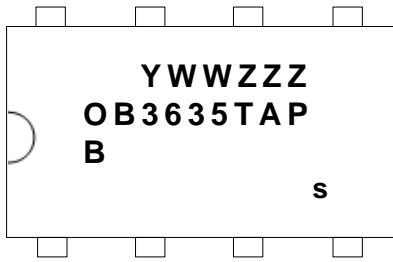

Y: Year Code  
 WW: Week Code (01-52)  
 ZZZ: Lot Code  
 A: DIP8  
 P: Halogen-free Package  
 B: Character Code  
 s: Internal Code(Optional)

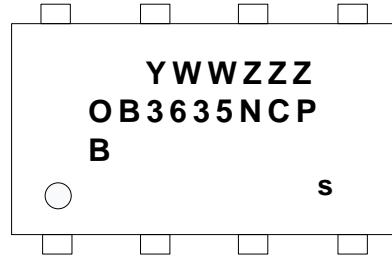

Y: Year Code  
 WW: Week Code (01-52)  
 ZZZ: Lot Code  
 C: SOP8  
 P: Halogen-free Package  
 B: Character Code  
 s: Internal Code(Optional)

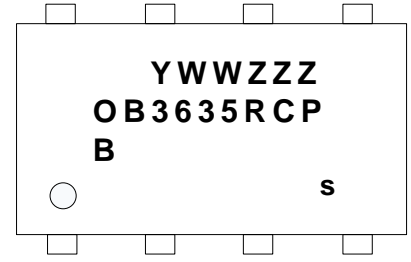

Y: Year Code  
 WW: Week Code (01-52)  
 ZZZ: Lot Code  
 C: SOP8  
 P: Halogen-free Package  
 B: Character Code  
 s: Internal Code(Optional)

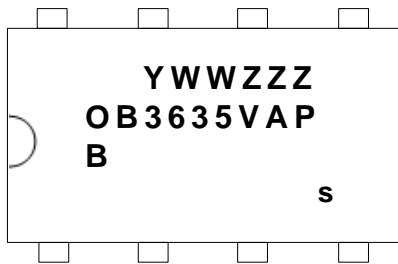

Y: Year Code  
 WW: Week Code (01-52)  
 ZZZ: Lot Code  
 A: DIP8  
 P: Halogen-free Package  
 B: Character Code  
 s: Internal Code(Optional)

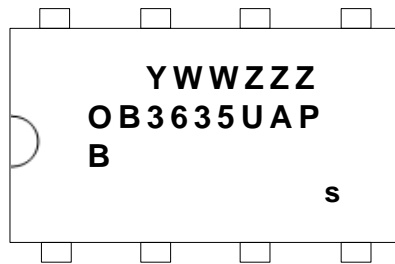

Y: Year Code  
 WW: Week Code (01-52)  
 ZZZ: Lot Code  
 A: DIP8  
 P: Halogen-free Package  
 B: Character Code  
 s: Internal Code(Optional)

### TERMINAL ASSIGNMENTS

Pin Num	Pin Name	I/O	Description
1	VDD	P	Power supply Input.
2	FB	I	The voltage feedback terminal.
3	GND	P	Power Ground
4	CMP	I/O	Loop compensation pin. A capacitor is connected between COMP and GND.
5	CS	I	Current sensing terminal.
6	SOURCE	I/O	MOSFET Source
7	DRIAN	I/O	MOSFET Drain terminal
8	DRIAN	I/O	MOSFET Drain terminal

**BLOCK DIAGRAM**

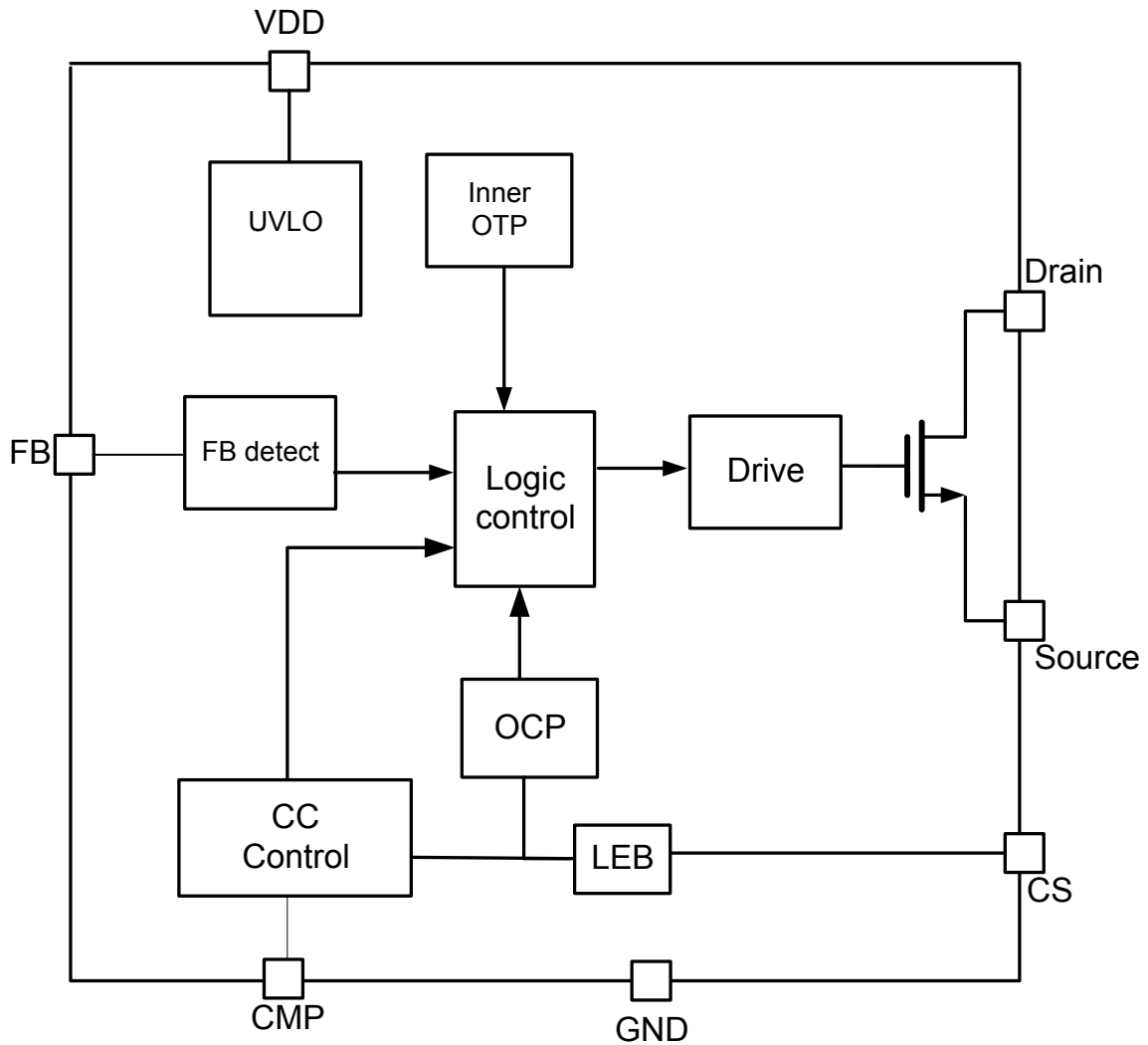

## ELECTRICAL CHARACTERISTICS

(TA = 25°C, VDD=20V, if not otherwise noted)

Symbol	Parameter	Test Conditions	Min	Typ.	Max	Unit
<b>Supply Voltage (VDD) Section</b>						
I <sub>start-up</sub>	Start up current	VDD=UVLO(OFF)-1V		3	7	uA
I <sub>op</sub>	Operation current	VDD=20V, no loading		0.4	0.6	mA
UVLO(OFF)	VDD under voltage lockout exit		16	18	20	V
UVLO(ON)	VDD under voltage lockout enter		7	8	9	V
VDD_clamp	VDD clamping Voltage		28	30	32	V
<b>Current Sense Input Section</b>						
TLEB	LEB time			0.4		us
Vth_ocp	Over Current Threshold	FB>0.25V	1.05	1.1	1.15	V
		FB<=0.25V		0.5		V
<b>FB Input Section</b>						
Vout_ovp	Output Over Voltage Protection		1.42	1.5	1.58	V
Vout_scp	Output Short Circuit Protection			0.25		V
I_FB	Maximum Sink current from FB				2	mA
<b>QR Section</b>						
Fmax	Maximum Clamping Frequency			100		KHz
Toff_max	Maximum Off Time			100		us
Toff_min	Minimum Off Time	CS>0.15V		2		us
		CS<=0.15V		0.5		us
Ton_max	Maximum On Time			25		us
<b>Error Amplifier Section</b>						
Vref	Error Amplifier Reference Voltage		0.196	0.200	0.204	V
Gm	Error Amplifier Transconductance			40		uS
Vclamp_cmp	CMP Pin Down_clamp Voltage			1.0		V
<b>OTP Section</b>						
T <sub>TF</sub>	Thermal regulation threshold			145		°C
OTP	Over Temperature Protection			170		°C

Product	Parameter	BVdss(V) MOSFET Drain-Source Breakdown Voltage		
		Min	Typ.	Max
OB3635BTAP-H		650		
OB3635BNCPA-H		650		
OB3635BRCPA-H		650		
OB3635BUAP-H		650		
OB3635BVAP-H		650		
OB3635BRCP		600		

**CHARACTERIZATION PLOTS**

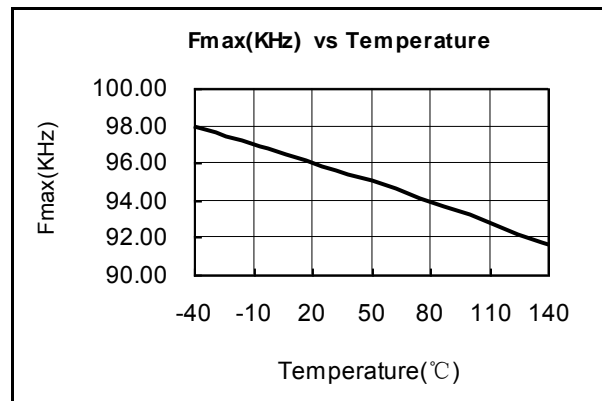
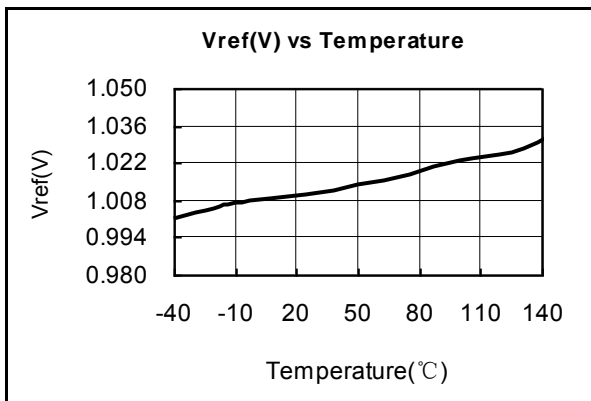
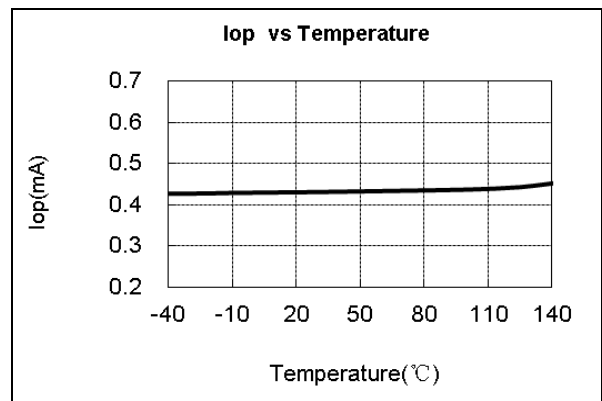
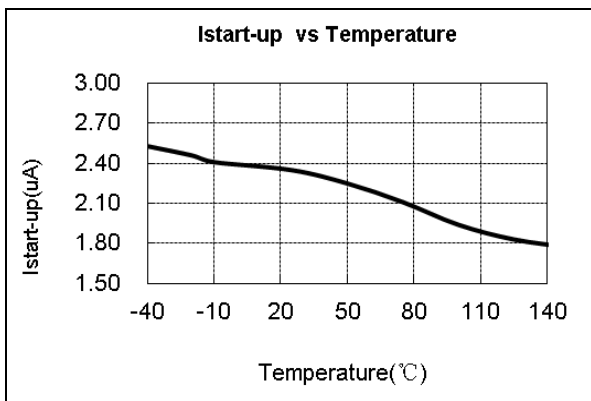
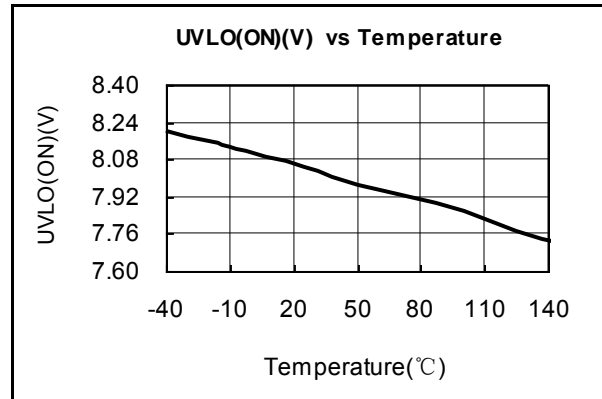
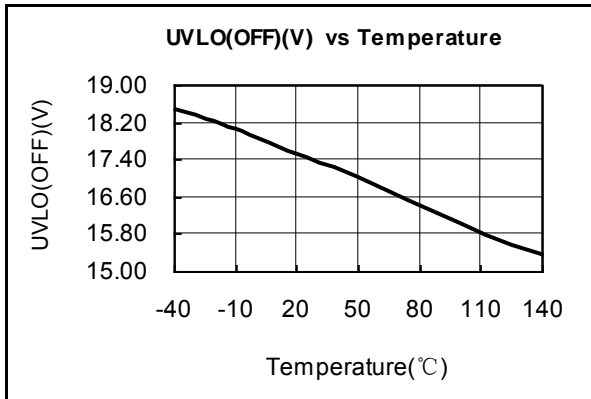

## OPERATION DESCRIPTION

OB3635Bx is a primary-side-control and high power factor, low THD fly-back PWM controller specialized for LED lighting application. It operates in primary side sensing and regulation without auxiliary winding. OB3635Bx works at Quasi-Resonant operation with maximum working frequency clamping, which can improve the efficiency of LED lighting system design.

### Start up Control

The advanced start-up technology is used in OB3635Bx to meet the start-up time requirement (<0.5s). Low start-up current is designed in OB3635Bx so that VDD could be charged up above UVLO threshold with small charging current.

At the startup, the capacitor at CMP pin is pulled up quickly. OB3635Bx operates at open loop and over-current protection is set cycle-by-cycle until it senses the output voltage by FB pin up to about 0.6V. After that OB3635Bx operates in close loop and the transconductance of error amplifier is set to 40uS (typical).

### LED Constant Current Regulation

The LED output current equals to the average of the output rectifier diode current. So the LED output current is related with the transformer peak current value and the transformer current discharge time. The transformer current discharge time is sensed through FB pin and the transformer peak current value is determined by internal reference voltage. A proprietary CC control block calculates LED output current through the CS pin peak current value and the transformer current discharge time. The output of the calculation is compared with an internal precise reference to generate an error voltage (Vcmp), which determines the turn-on time in voltage mode control. The LED output current can be approximated as:

$$I_{LED} = \eta \cdot \frac{N}{2} \cdot \frac{V_{ref}}{R_{CS}}$$

$\eta$  — The transformer coupling coefficient.

N — Turn ratio of primary side winding to secondary side winding.

Rcs — The sensing resistor connected between the MOSFET source and GND.

Vref — Internal reference voltage.

### PFC and THD

The duration of the turn on period  $t_{on}$  is generated by comparing an internal fixed saw-tooth wave with the voltage on the CMP pin. During steady state operation, the voltage on the CMP pin Vcmp is slowly varying due to a large external capacitor connected at the CMP pin, therefore the turn on time  $t_{on}$  is constant. In a fly-back topology,

constant turn on time and quasi-resonant operation provide high power factor (PF) and low total harmonic distortion (THD).

### Current Sensing and Leading Edge Blanking

Cycle-by-Cycle current limiting (OCP) is offered in OB3635Bx. The switching current is detected by a sense resistor connected between the CS pin and GND. An internal leading edge blanking circuit chops off the sense voltage spike at initial MOSFET on state due to snubber diode reverse recovery so that the external RC filter is no longer required. The current limit comparator is disabled at this blanking time and thus the external MOSFET cannot be turned off during this blanking time.

### Quasi-Resonant Operation

OB3635Bx performs quasi-resonant detection through FB pin by monitoring the voltage activity on the primary windings in series with external resistors. When the stored energy of fly-back transformer is fully released to the output, the voltage at FB pin decreases. When FB pin voltage falls below 0.05V (typical), an internal FB comparator is triggered and a new PWM switching cycle is initiated following the FB triggering.

### Line/Load Compensation

OB3635Bx provides internal line compensation and load compensation to avoid using outside sensing devices. The compensated voltage is added to CS voltage cycle-by-cycle and LED output current is kept constant under different line voltage and output voltage.

### Thermal Fold-back Protection

OB3635Bx provides thermal foldback function to control LED output current. When temperature is up to 145°C (typical) and the output current of system will be adjusted according to the sensed temperature. The output current will be reduce to about half of the setting value at 165°C (typical). Over temperature protection is offered in OB3635Bx. When temperature rises above 170°C (typical), the device will stop working.

### LED Short Circuit Protection

When LED string is short, the FB voltage is low. If the voltage at FB pin is lower than a threshold of approximately 0.25V (typical), the IC will work at minimum frequency and the threshold voltage of OCP is reduced to 0.5V (typical). The power dissipation is greatly reduced in this way.

### LED Open Circuit Protection

When the LED string open circuit happens, the FB pin voltage is high. If the voltage at FB pin is higher than a threshold of approximately 1.5V (typical), the IC will shut down and enter power on startup sequence thereafter.



## PACKAGE MECHANICAL DATA

8-Pin Plastic SOP

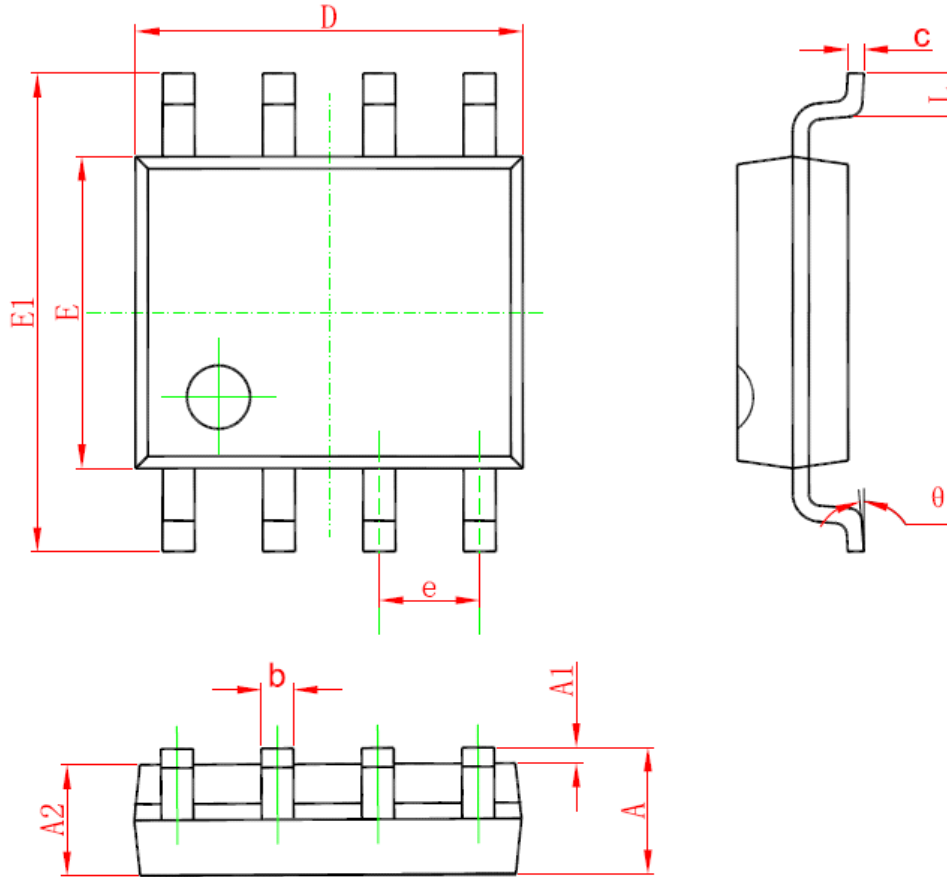

Symbol	Dimensions In Millimeters		Dimensions In Inches	
	Min	Max	Min	Max
A	1.350	1.750	0.053	0.069
A1	0.050	0.250	0.002	0.010
A2	1.250	1.650	0.049	0.065
b	0.310	0.510	0.012	0.020
c	0.100	0.250	0.004	0.010
D	4.700	5.150	0.185	0.203
E	3.800	4.000	0.150	0.157
E1	5.800	6.200	0.228	0.244
e	1.270 (BSC)		0.050 (BSC)	
L	0.400	1.270	0.016	0.050
θ	0°	8°	0°	8°

## 8-Pin Plastic DIP

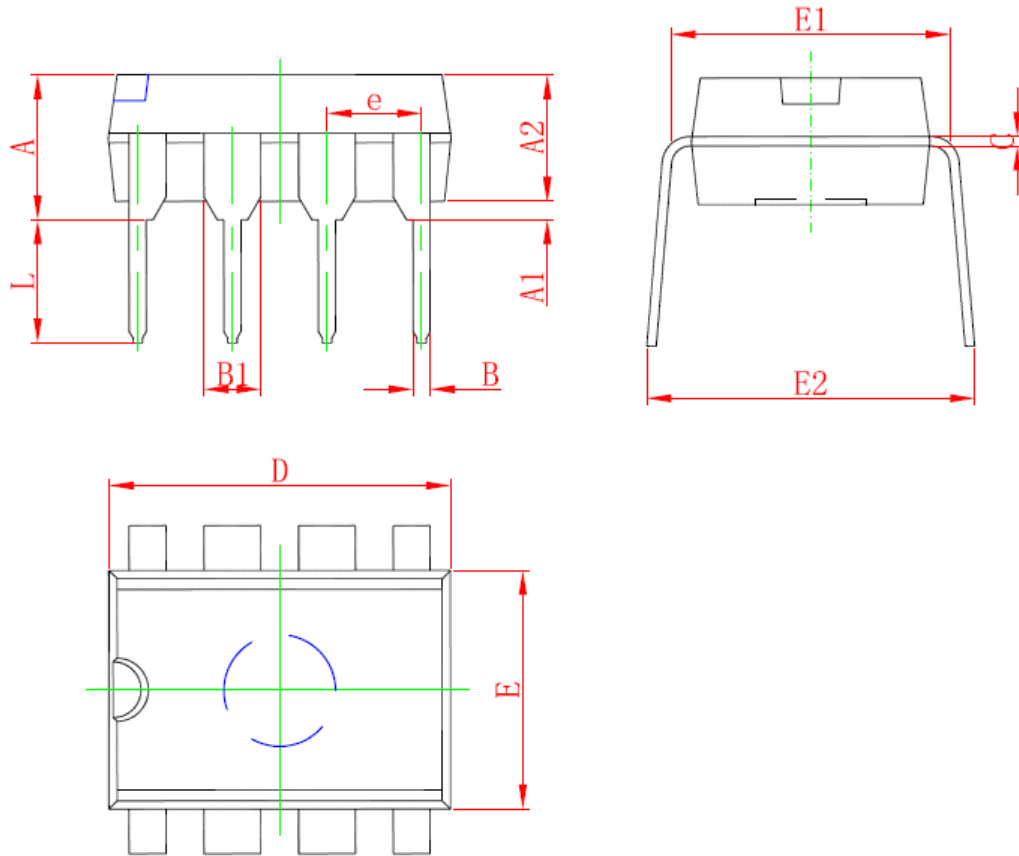

Symbol	Dimensions In Millimeters		Dimensions In Inches	
	Min	Max	Min	Max
A	3.710	5.334	0.146	0.210
A1	0.381		0.015	
A2	2.921	4.953	0.115	0.195
B	0.350	0.650	0.014	0.026
B1	1.524 (BSC)		0.06 (BSC)	
C	0.200	0.360	0.008	0.014
D	9.000	10.160	0.354	0.400
E	6.096	7.112	0.240	0.280
E1	7.320	8.255	0.288	0.325
e	2.540 (BSC)		0.1 (BSC)	
L	2.921	3.810	0.115	0.150
E2	7.620	10.920	0.300	0.430

## **IMPORTANT NOTICE**

### **RIGHT TO MAKE CHANGES**

On-Bright Electronics Corp. reserves the right to make corrections, modifications, enhancements, improvements and other changes to its products and services at any time and to discontinue any product or service without notice. Customers should obtain the latest relevant information before placing orders and should verify that such information is current and complete.

### **WARRANTY INFORMATION**

On-Bright Electronics Corp. warrants performance of its hardware products to the specifications applicable at the time of sale in accordance with its standard warranty. Testing and other quality control techniques are used to the extent it deems necessary to support this warranty. Except where mandated by government requirements, testing of all parameters of each product is not necessarily performed.

On-Bright Electronics Corp. assumes no liability for application assistance or customer product design. Customers are responsible for their products and applications using On-Bright's components, data sheet and application notes. To minimize the risks associated with customer products and applications, customers should provide adequate design and operating safeguards.

### **LIFE SUPPORT**

On-Bright Electronics Corp.'s products are not designed to be used as components in devices intended to support or sustain human life. On-bright Electronics Corp. will not be held liable for any damages or claims resulting from the use of its products in medical applications.

### **MILITARY**

On-Bright Electronics Corp.'s products are not designed for use in military applications. On-Bright Electronics Corp. will not be held liable for any damages or claims resulting from the use of its products in military applications.