

SPECIFICATION FOR APPROVAL

承 認 書

Description : Speaker

Kingstate Part No. : KDMG50008C-10AW

Customer's Model No. : _____

Specification No. : POD-7725

Number Of The Edition : 1.1

CUSTOMER'S APPROVED SIGNATURE		

志豐電子股份有限公司 KINGSTATE ELECTRONICS CORP.



KINGSTATE Address: 10F, No. 69-11, Sec. 2, Chung Cheng E. Rd., Tamshui County, Taipei Hsien, Taiwan, R.O.C.

International sales dept.: TEL:886-2-2809-5651 FAX:886-2-2809-7151

Domestic sales dept.: TEL:886-2-2809-0668 FAX:886-2-28096748

<http://www.kingstate.com.tw>

Approved by	Checked by	Issued by
		FAN 2021.12.29

KINGSTATE ELECTRONICS CORPORATION

志豐電子股份有限公司

變更履歷表

圖號 Drawing no. : POD-7725		機種 P/N: KDMG50008C-10AW	
變更日期 Date modified	提出者 Applied	版本 Edition	變更內容 Modified content
2021.12.29	羅光明	1.1	規格書建立

A. SCOPE 範疇

This specification applies speaker, **KDMG50008C-10AW**

此規格書適用於喇叭, **KDMG50008C-10AW**

B. SPECIFICATION 規格

No.	Item	Symbol	Unit	Specification	Condition
1	Dimension 尺寸		mm	Ø50*7.5H	
2	Rated Power 額定功率		W	Ⓒ 1W (2.83V)	
3	Max Power 最大功率		W	1.5W (3.46V)	Maximum Power:IEC-60268-5 Filter 60s ON/120s Off 10 Cycles(Room Temp)
4	Impedance 阻抗	Ω	ohm	Ⓒ8± 15%	At 2.0KHz
5	Resonance Frequency 低音諧振	Fo	Hz	Ⓒ250± 20% Hz	At 1.0V
6	Output S.P.L. 音壓位準		dB	Ⓒ92± 3dB(0.1W/0.1m)	At0.8KHz,1KHz,1.2KHz,1.5K Hz(Average figures)
7	Frequency Rang 有效頻寬		Hz	ⒸFO---20K	Average SPL -10db
8	Distortion 失真		%	Ⓒ <10%	At 1.0KHz 0.1W
9	Diaphragm 振膜			PET	
10	Magnet 磁石		mm	Φ12.5*1.5	Nd-Fe-B
11	Flux Density 磁通密度		Gauss	N/A	
12	Operating temp. 操作溫度		℃	-20 ~ +60	
13	Storage temp. 儲存溫度		℃	-20 ~ +60	
14	Buzze & Rattle 異常音				Not be audible at 2.83V sine wave between From FO~20K 輸入 2.83V 正弦波從 FO 到 20K 之間無異常音
15	Piece weight/Out Box weight 單重 / 箱重		g	N/A	
16	Material 材質			SPCC	
17	Polarity 極性			Diaphragm shall move Forward when Apply a Positive DC Current to the “+”	
18	Environmental Protection Regulation 環保法規			RoHS2.0	

C. SPEAKER CHARACTERISTICS 頻率響應曲線

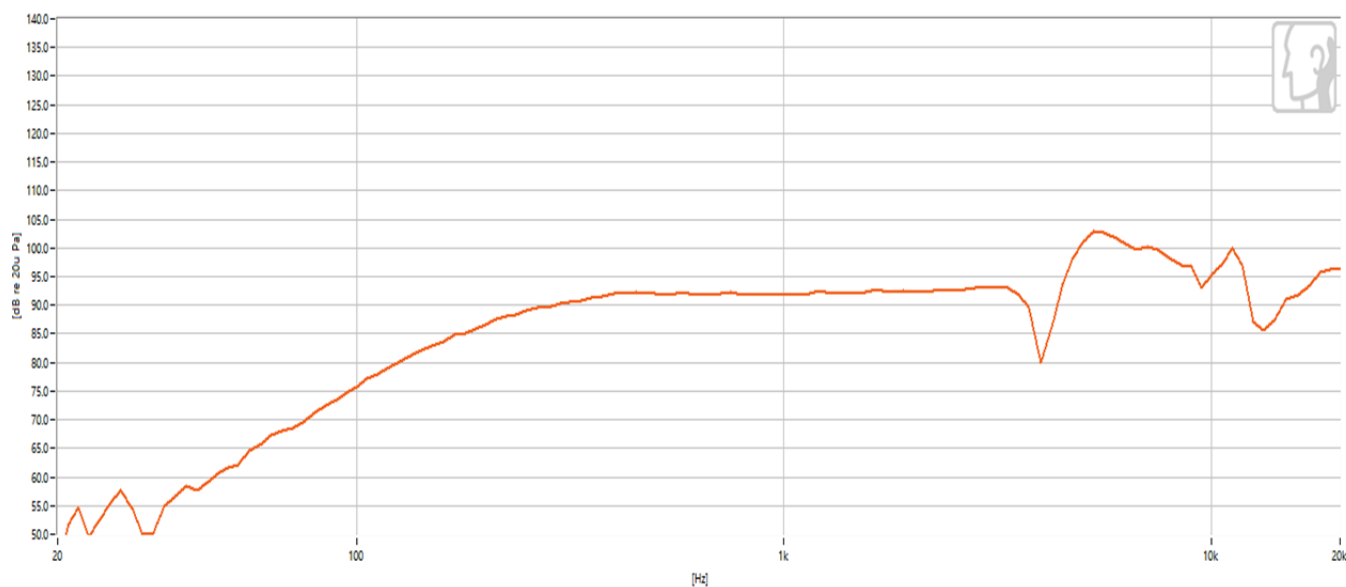

D. APPEARANCE DRAWING 外觀尺寸圖

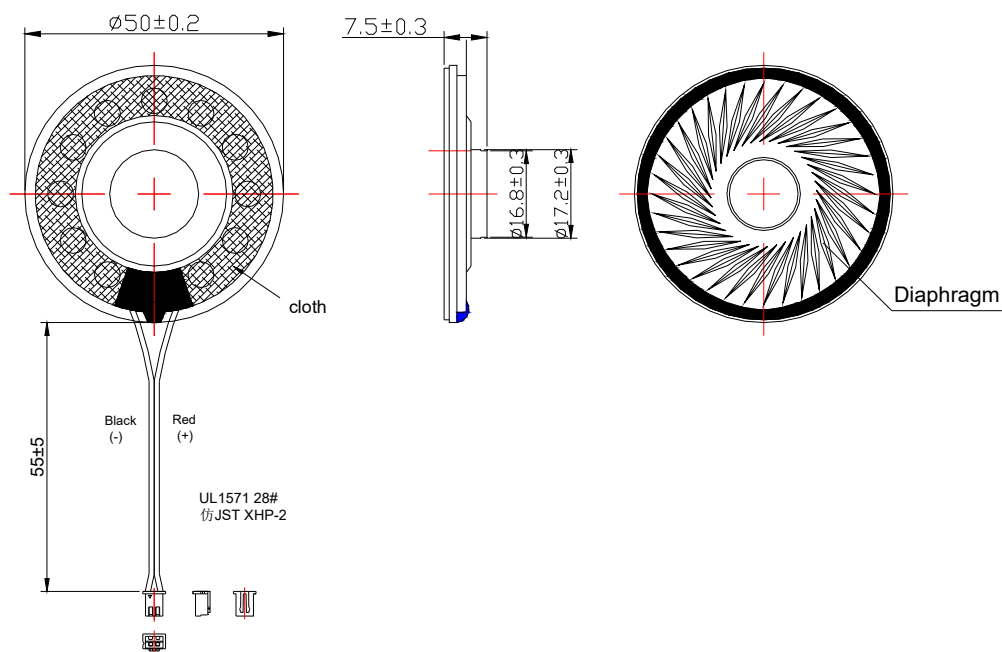

Tol: ± 0.5 Unit: mm

E. MEASUREMENT CIRCUIT 測量線路

Speaker Testing framework diagram

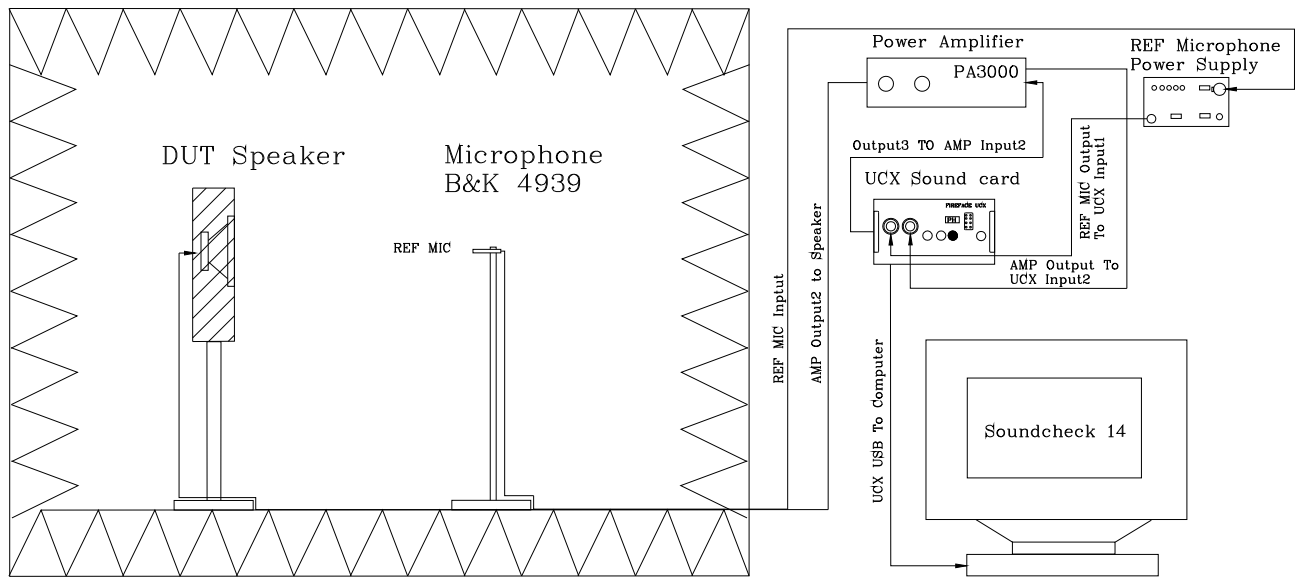

F. MECHANICAL CHARACTERISTICS 機械特性

No.	Item	Test condition	Evaluation standard
1	Solderability 焊錫附著性 (Connector excepted) 端子類不適用此項	Stripped wires of lead wires are immersed in rosin for 5 seconds and then immersed in solder bath of $+270\pm 5^{\circ}\text{C}$ for 3 ± 0.5 seconds. 裸線部份浸入松香溶液 5 秒後,再浸入 $+270\pm 5^{\circ}\text{C}$ 溶融焊錫槽 3 ± 0.5 秒.	90% min. stripped wires shall be wet with solder.(Except the edge of terminal) 浸入裸線部份附著焊錫 90% 以上.(末端斷面不算).
2	Vibration Test 振動測試	Speaker shall be measured after being applied vibration of amplitude of 1.5mm with 10 to 55Hz band of vibration frequency to each of 3 per-pendicular directions for 2 hours. 振動週波數 10~55Hz、全振幅 1.5mm 於 X.Y.Z 3 個方向, 各 2 小時.	No obstacle to be harmful to normal operation; damages, cracks, rusts and distortions. Should not be audible at 2.83V sine wave between FO ~20KHz.
3	Drop Test 落下測試	Drop the speakers contained in normal box onto the board 40mm thick 2times from the height of 75cm 將揚聲器置於盒中, 自 75 公分高度落在 40mm 木板上共 2 次.	測試後無任何障礙防礙正常操作.輸入 2.83V 正弦波從 FO 到 20KHz 之間無異常音.

G. ENVIRONMENTAL TEST 環境試驗

No.	Item	Test conditions	Evaluation standard
1	High temp. Test 高溫測試	After being placed in a chamber at +60°C for 96 hours. 置於+60°C 環境中 96 小時	Being placed for 6 hours at +25°C, speaker shall be measured. No obstacle to be harmful to normal operation; damages, cracks, rusts, etc.
2	Low temp. Test 低溫測試	After being placed in a chamber at -20°C for 96 hours. 置於-20°C 環境中 96 小時	
3	Humidity test 相對濕度測試	After being placed in a chamber at +30°C and 90~95% RH relative humidity for 96 hours. 置於+30°C, 相對濕度 90~95% 環境中 96 小時	
4	Temp. cycle test 溫度循環測試	<p>The part shall be subjected to 5 cycles. One cycle shall be consist of: 單體承受溫度循環測試 5 次, 其循環內容如圖示:</p> <p>The diagram illustrates a temperature cycle test profile. It starts at +60°C for 2 hours, then ramps down to +25°C in 0.5 hours. It remains at +25°C for 1 hour, then ramps down to -20°C in 0.5 hours. It remains at -20°C for 2 hours. The total duration of one cycle is 6 hours, indicated by a dashed line at the bottom.</p>	<p>Should not be audible at 2.83V sine wave between FO to 20K. Fo should meet initial one. S.P.L. deviation of unit should be within ±3dB 經測試後, 靜置於+25°C (室溫) 環境中 6 小時後, 測試後無任何障礙防礙正常操作. 輸入 2.83V 正弦波從 FO 到 20K 之間無異常音. Fo 與原規格值相同, 輸出音壓變化量在 ±3dB 內.</p>

H. RELIABILITY TEST 信賴性試驗

No.	Item	Test conditions	Evaluation standard
1	Load test 連續負荷	1W White noise is applied for 96 hours, at room temp product. 在室溫下, 輸入功率 1W, 白噪音連續操作 96 小時.	<p>Being placed for 1 hours at +25°C, speaker shall be measured. No obstacle to be harmful to normal operation; damages, cracks, rusts, etc. Should not be audible at 2.83V sine wave between FO to 20K. Fo should meet initial one. S.P.L. deviation of unit should be within ±3dB 經測試後, 靜置於+25°C (室溫) 環境中 1 小時後, 測試後無任何障礙防礙正常操作. 輸入 2.83V 正弦波從 FO 到 20K 之間無異常音. Fo 與原規格值相同, 輸出音壓變化量在 ±3dB 內.</p>

TEST CONDITION.

Standard Test Condition :	a) Temperature : +15 ~ +35°C	b) Humidity : 45-85%	c) Pressure : 860-1060mbar
一般測試條件 :	a) 溫度 : +15 ~ +35°C	b) 濕度 : 45-85%	c) 氣壓 : 860-1060mbar
Judgement Test Condition	a) Temperature : +20 ± 3°C	b) Humidity : 60-70%	c) Pressure : 860-1060mbar
爭議時測試條件:	a) 溫度 : +20 ± 3°C	b) 濕度 : 60-70%	c) 氣壓 : 860-1060mbar

I.PACKING STANDARD 包裝規格

units: cm

Remark:

50pcs per tray

10 trays for unit, 1 units per carton

Total:500 pcs per box

Size:42*32*35cm

