

A

B

C

D

E

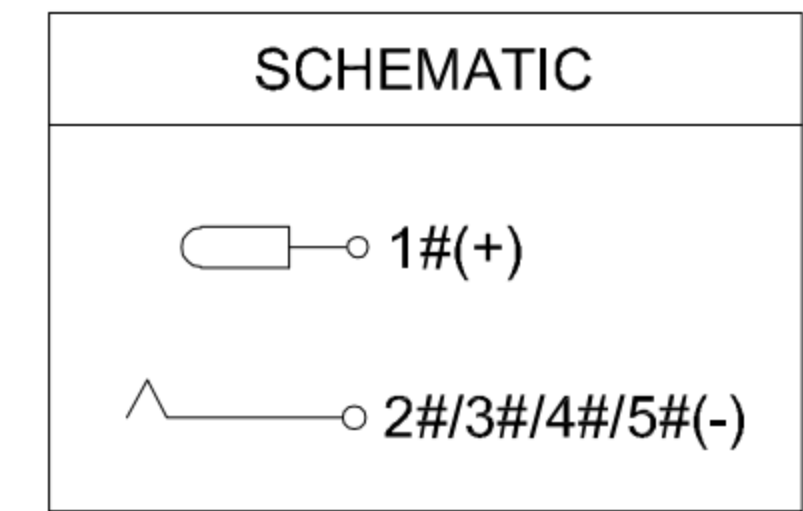
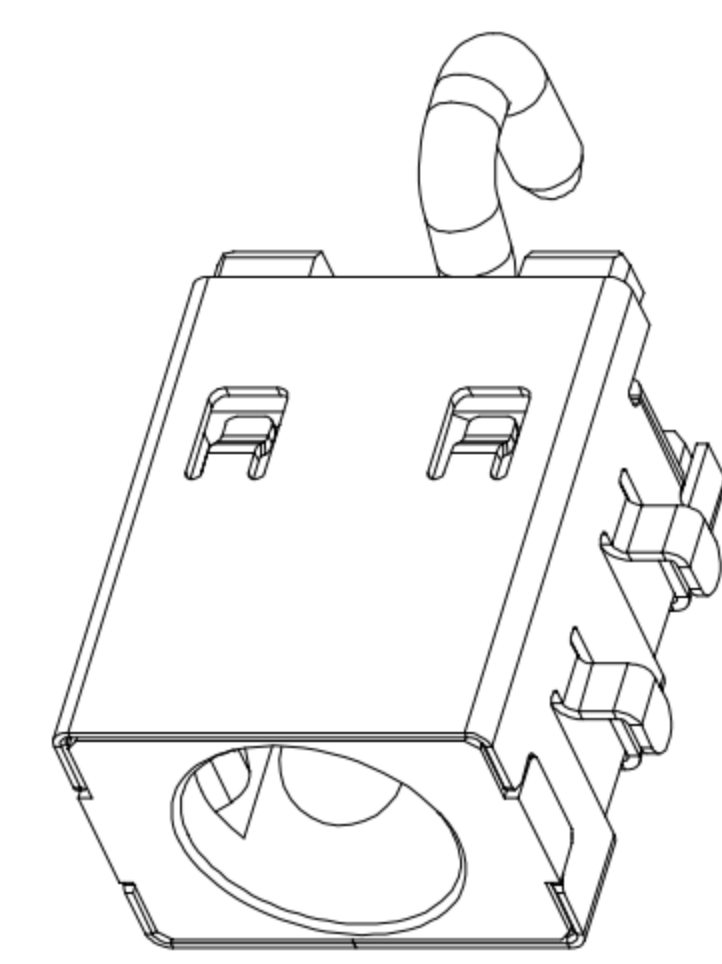
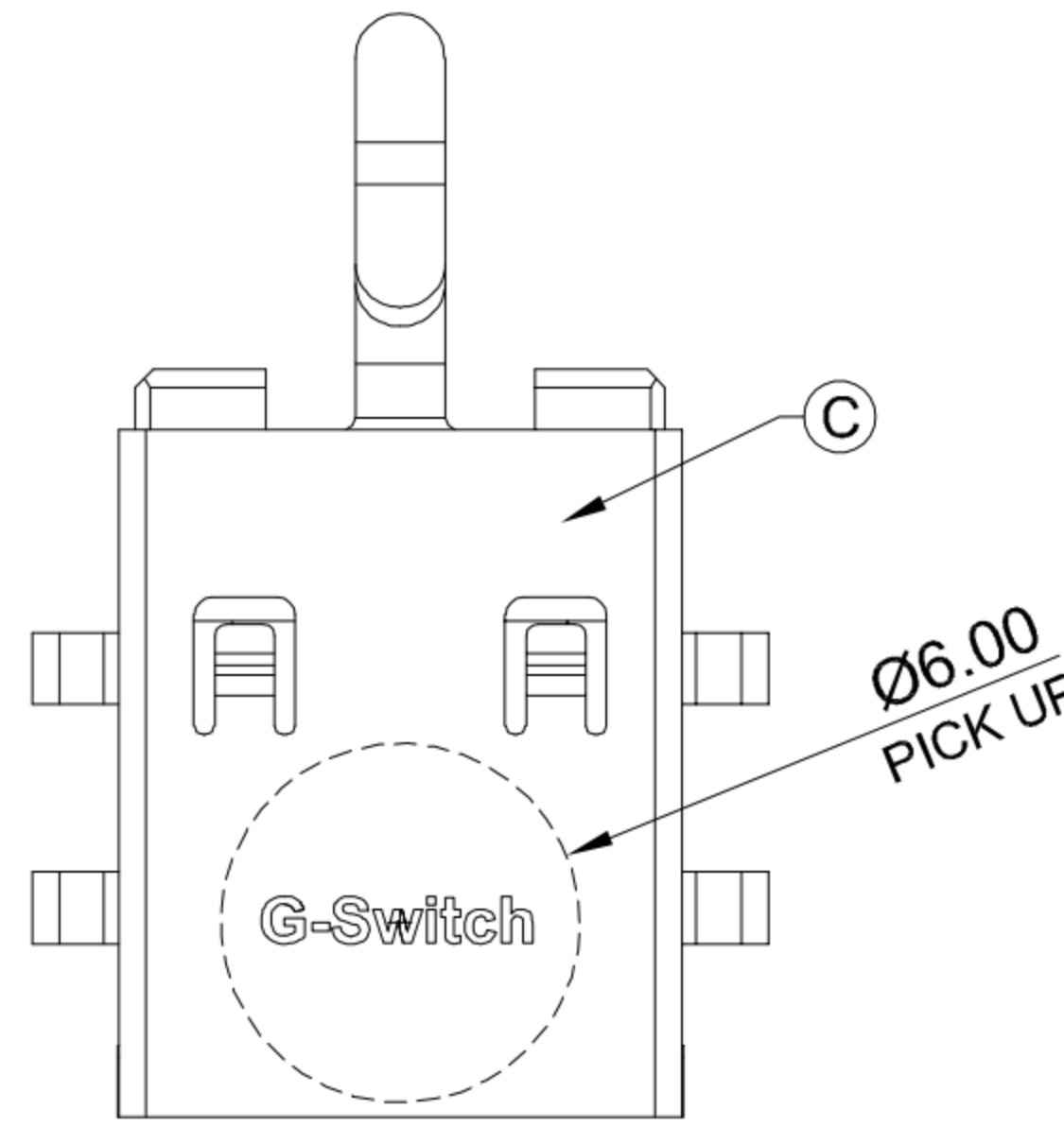

CIRCUIT DIAGRAM

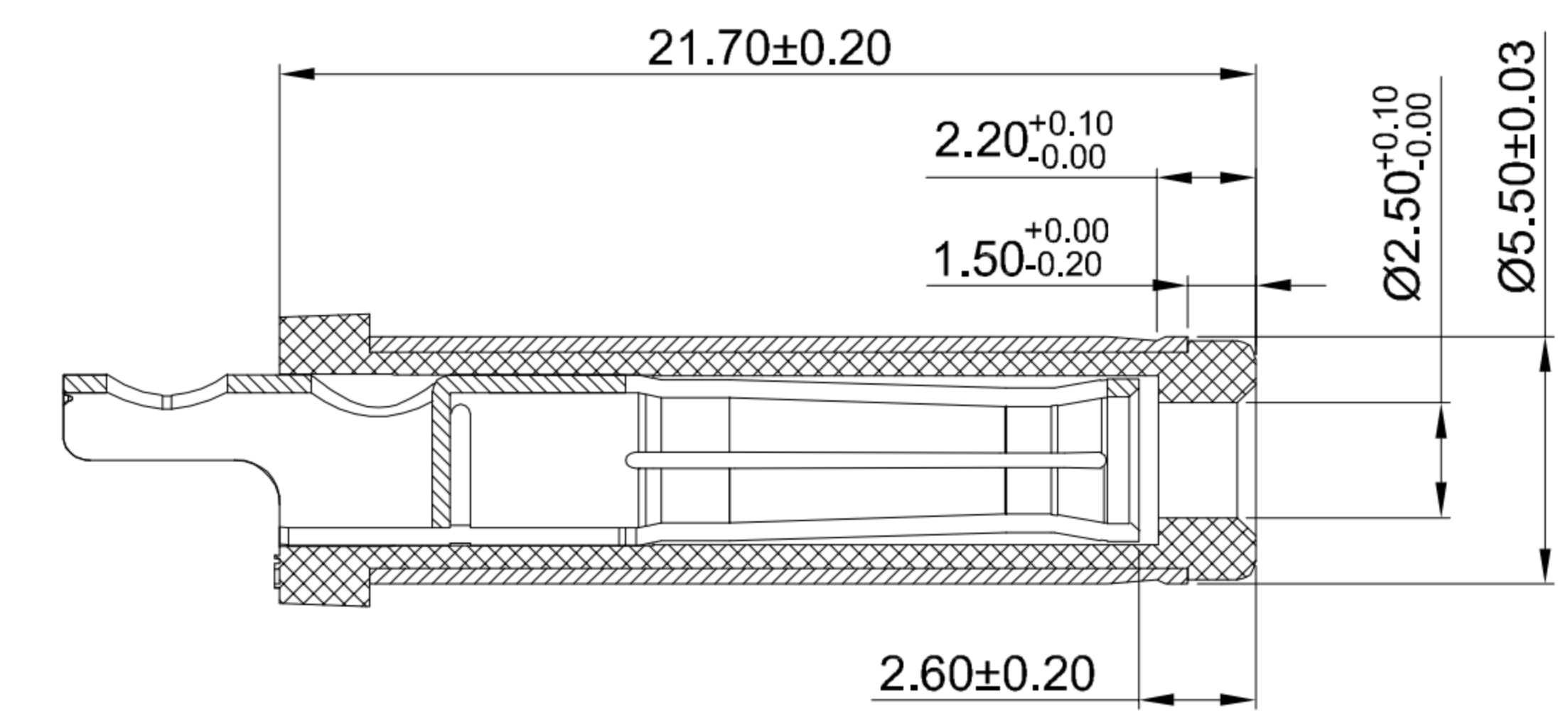
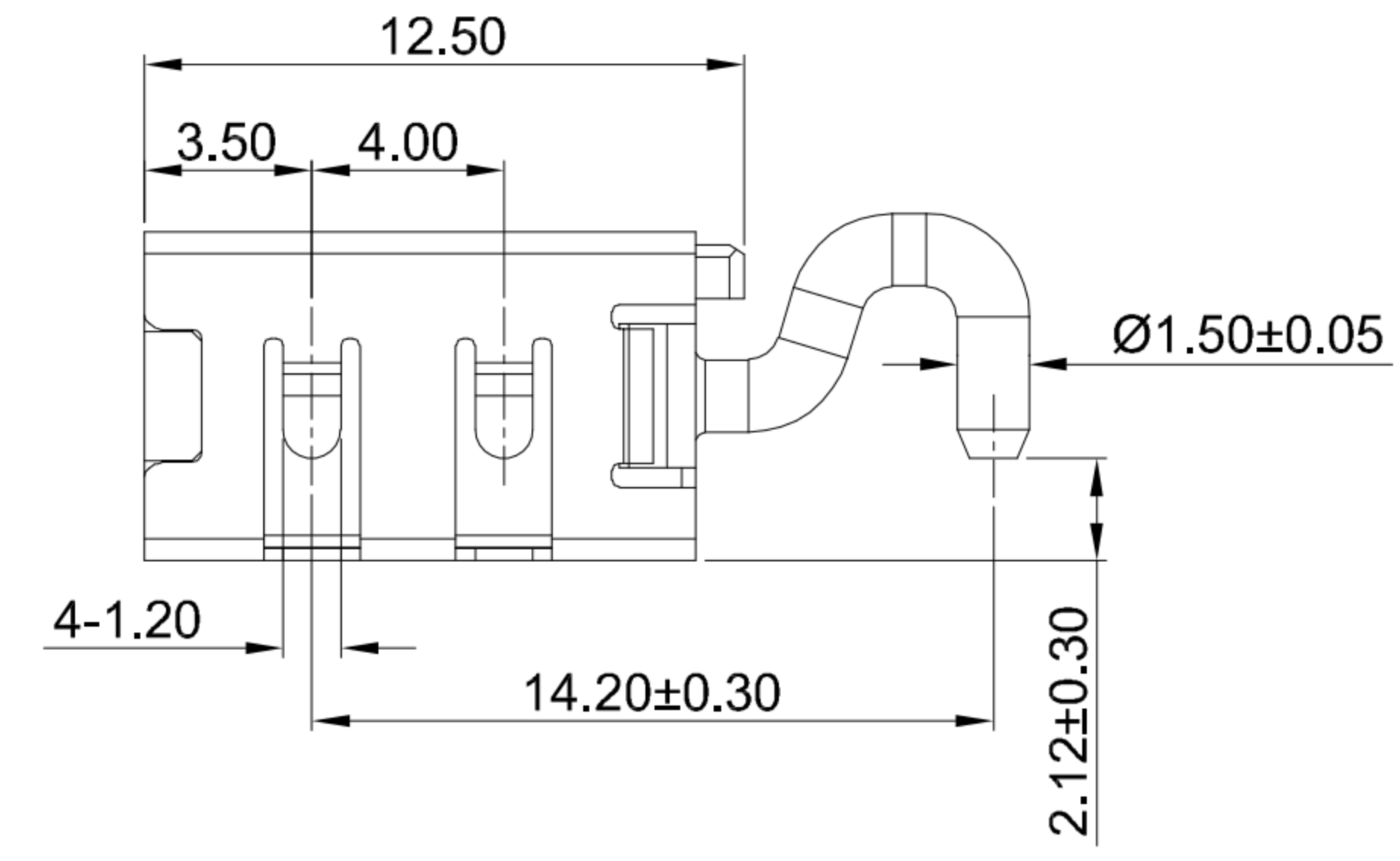
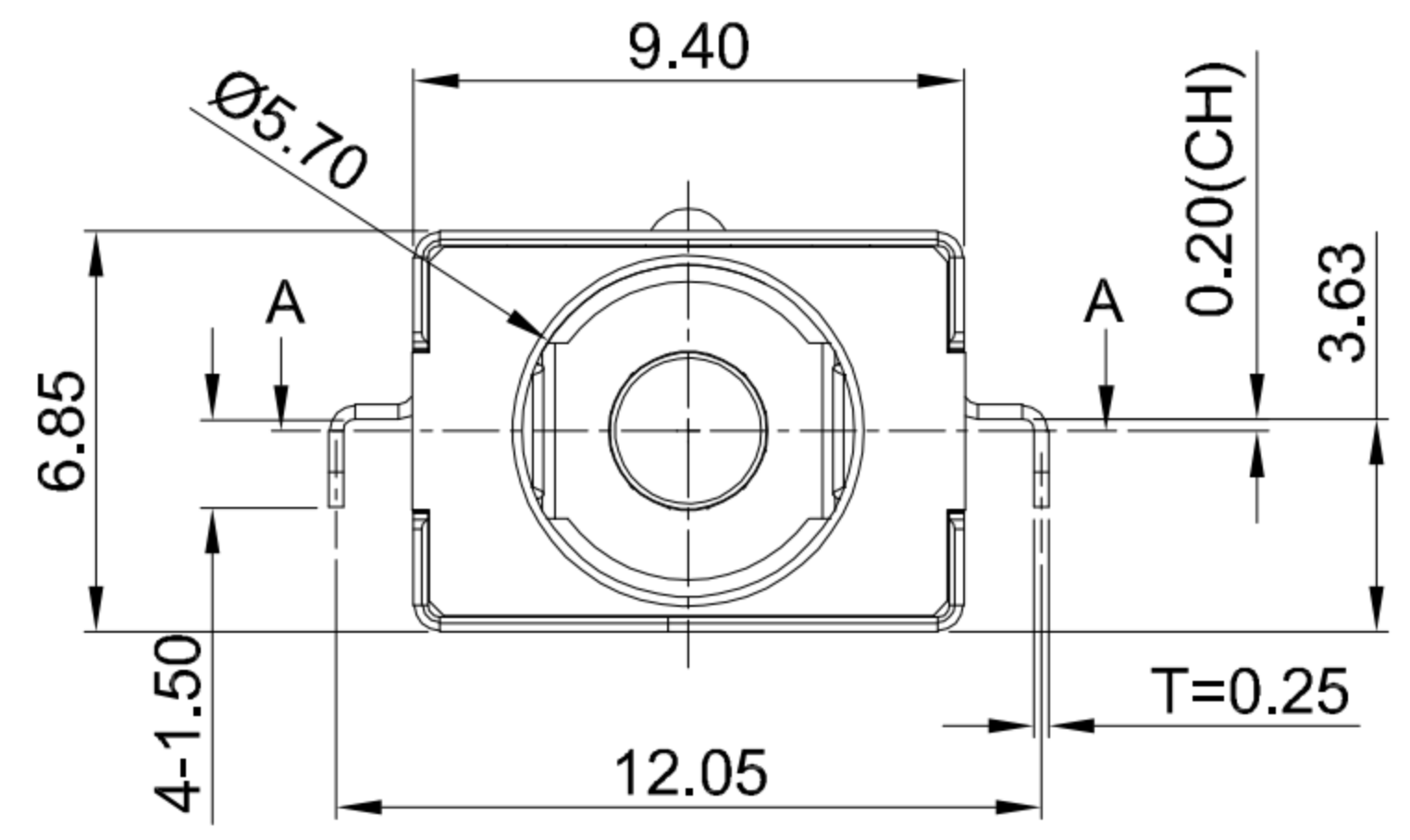
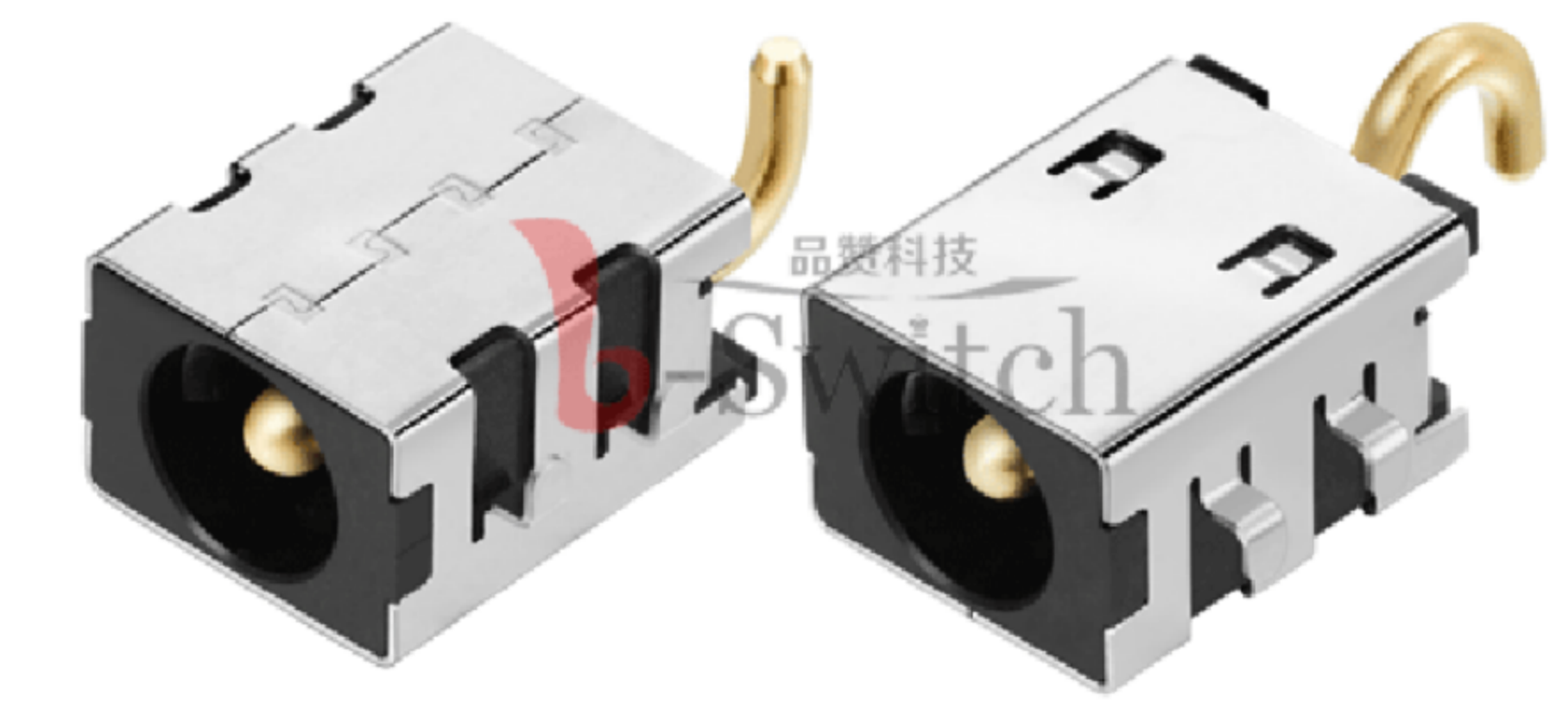

MATING PLUG Ø5.5xØ2.5mm

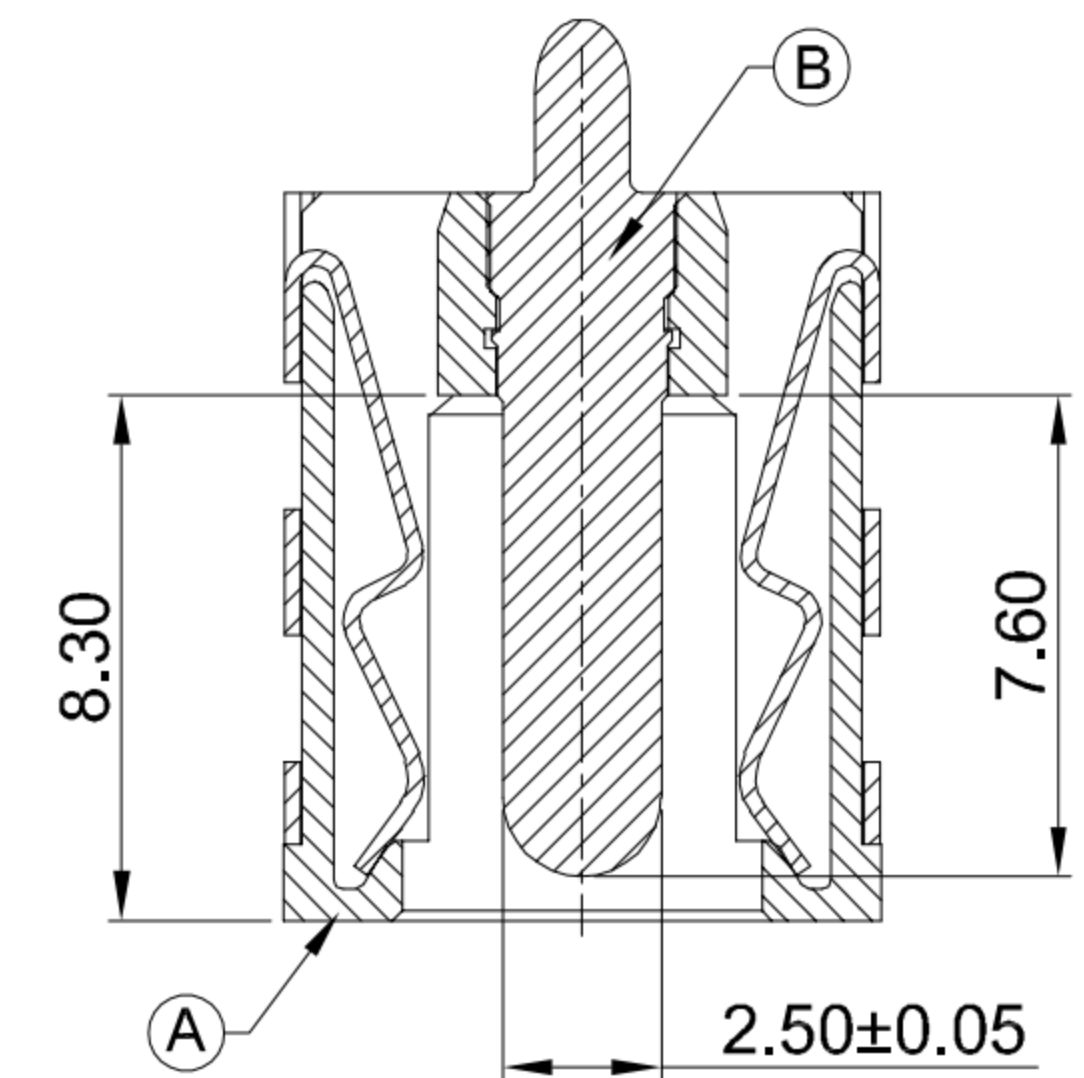

SECTION A-A

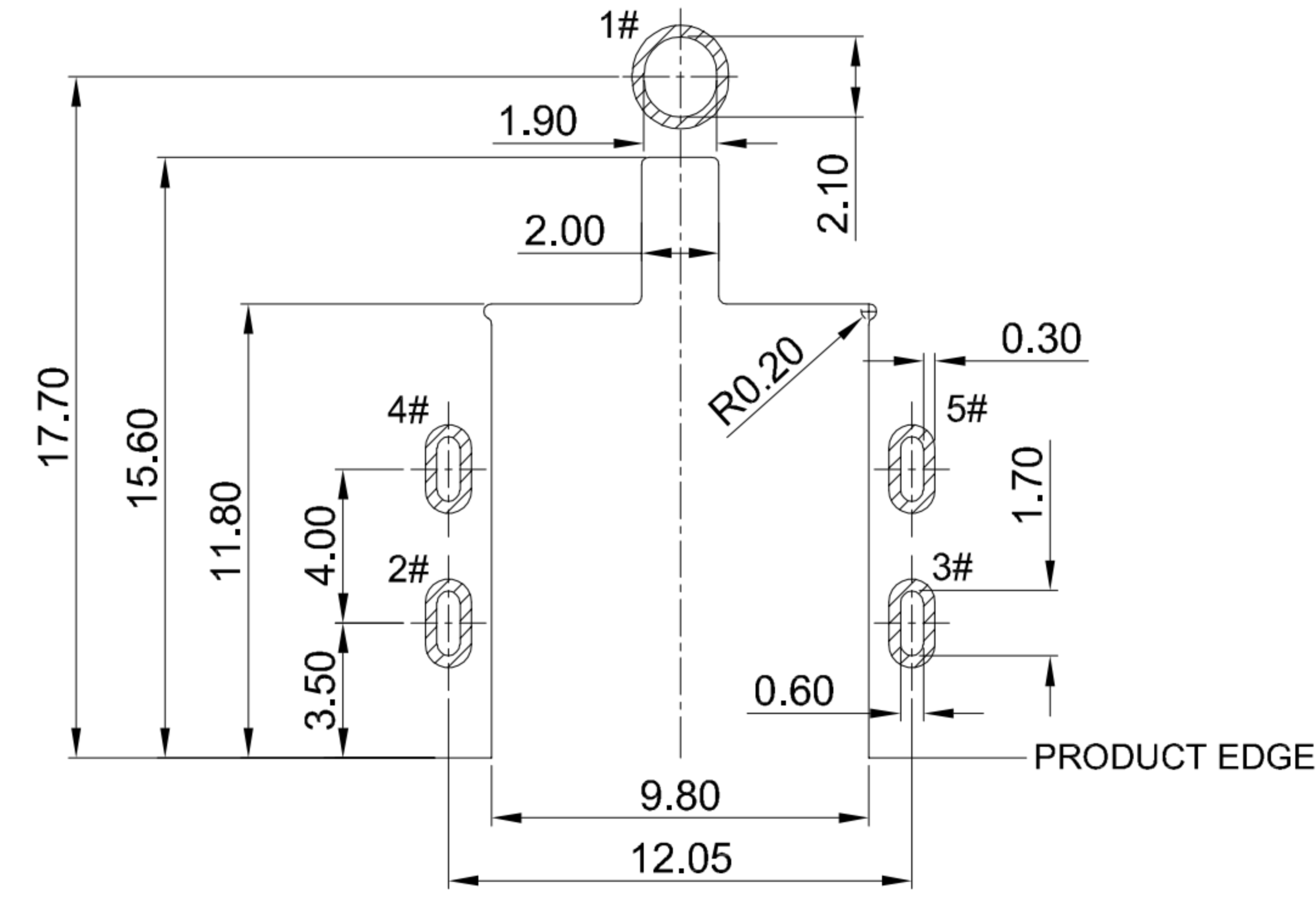

RECOMMENDED PCB LAYOUT TOLERANCE:±0.05

**G-Switch Specification:**

1. Operating temperature range: -40°C ~ +85°C
2. Rated load: 15A.30V DC
3. Insulation resistance: 100MΩ min
4. Withstand voltage: 500V AC/min
5. Contact resistance: 30mΩ max(Initial), 50mΩ max(Final)
6. Durability cycle: 5,000 Cycles
7. Insertion and extraction force: 3-30N

A	HOUSING	HIGH TEMPERATURE PLASTIC	PA10T BLACK
B	CENTER PIN	BRASS	GOLD FLASH
C	SHELL	COPPER ALLOY C5210	Ni PLATING
NO.	PART NAME	MATERIAL	REMARK



SCALE: 1:1	UNIT: mm
SIZE: A4	
Unless otherwise General tolerance:	
X	±0.50
X.x	±0.30
X.xx	±0.20
X.xxx	±0.10
X.x°	±3°

Title: Horizontal DC Power Jack 5525 DIP Sink3.63 CH=0.2 Ø2.5mm			
Molde Code: DC-S012A-D025-15A			
DRAWN	CHECKED	APPROVED	DATE
Xia	Chen	Chen	2023.02.01



REV: A0	SHEET: 1/1
---------	------------

A

B

C

D

E

5

5