

SOT-23 Plastic-Encapsulate CAN bus ESD Protection Diodes

DESCRIPTION

The ESD2105L has been designed to protect the CAN transceiver in high-speed and fault tolerant networks from ESD and other harmful transient voltage events. This device provides bidirectional protection for each data line with a single compact SOT-23 package, giving the system designer a low cost option for improving system reliability and meeting stringent EMI requirements.

Features

- ◆ 350 Watts Peak Pulse Power per (8/20 μ s)
- ◆ Transient protection for asymmetrical data lines to IEC61000-4-2 (ESD) \pm 15kV (air), \pm 8kV (contact)
IEC61000-4-4 (EFT) 40A (5/50ns)
IEC61000-4-5 (Lightning) 8A (8/20 μ s)
- ◆ Working voltages : 24V
- ◆ Low leakage current
- ◆ Low clamping voltage
- ◆ Meets MSL 1 Requirements

Pin Configuration

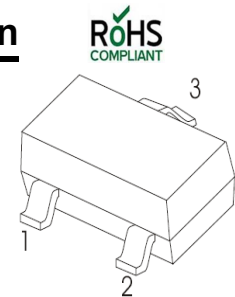

Circuit Diagram

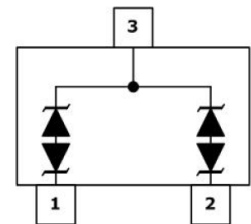

Applications

- ◆ Industrial Control Networks
- ◆ Smart Distribution Systems
- ◆ Automotive Networks
- ◆ Low and High-Speed CAN
- ◆ Fault Tolerant CAN

Mechanical Characteristics

- ◆ Package: SOT-23
- ◆ Flammability Rating: UL 94V-0
- ◆ Terminal: Matte tin plated.
- ◆ High temperature soldering guaranteed: 260 C/10s
- ◆ Marking: 27E
- ◆ Packaging: Tape and Reel

Absolute Maximum Ratings (T_A=25°C unless otherwise specified)

Parameter	Symbol	Value	Unit
Peak Pulse Power(8/20 μ s)	P _{PP}	350	W
ESD per IEC 61000-4-2 (Air)	V _{ESD}	\pm 30	KV
ESD per IEC 61000-4-2 (Contact)		\pm 30	
Operating Temperature	T _{OPT}	-55 to +150	°C
Storage Temperature	T _{STG}	-55 to +150	°C
Lead Solder Temperature – Maximum (10 Second Duration)	T _L	260(10 sec.)	°C

The above data are for reference only.

**Electrical Characteristics** ($T_A=25^{\circ}\text{C}$ unless otherwise specified)

Symbol	Parameter	Test Condition	Min	Typ	Max	Units
V_{RWM}	Reverse Working Voltage	Pin 1,2 to Pin3			24	V
V_{BR}	Reverse Breakdown Voltage	$I_T = 1\text{mA}$ Pin 1,2 to Pin3	26.2		32	V
I_R	Reverse Leakage Current	$V_{RWM} = 24\text{V}$ Pin 1,2 to Pin3		15	100	nA
V_{C1}	Clamping Voltage 1	$I_{PP} = 1\text{A}$, $t_p = 8/20\mu\text{s}$ Pin 1,2 to Pin3			36	V
V_{C2}	Clamping Voltage 2	$I_{PP} = 5\text{A}$, $t_p = 8/20\mu\text{s}$ Pin 1,2 to Pin3			46	V
C_J	Junction Capacitance	$V_R = 0\text{V}$, $f = 1\text{MHz}$ Pin 1,2 to Pin3		25	30	pF

The above data are for reference only.

ELECTRICAL CHARACTERISTICS CURVE

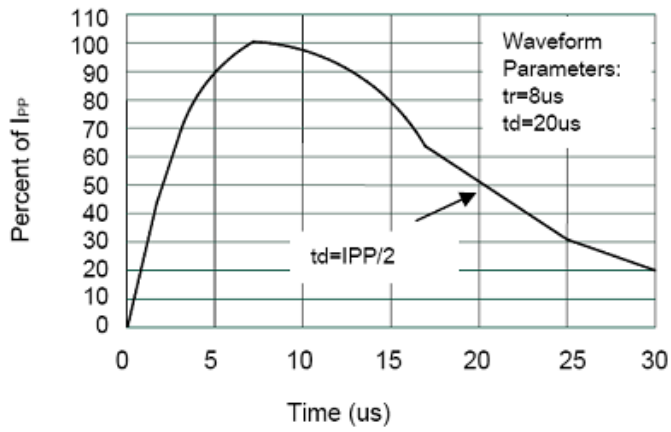

Pulse Waveform

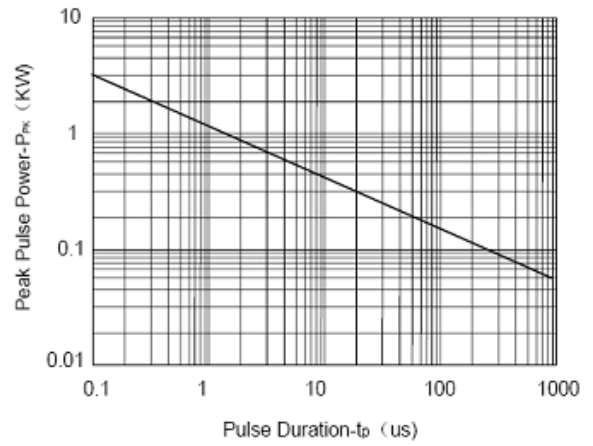

Non-Repetitive Peak Pulse Power vs. Pulse Time

The curve above is for reference only.

Outline Drawing

SOT-23 Package Outline Dimensions

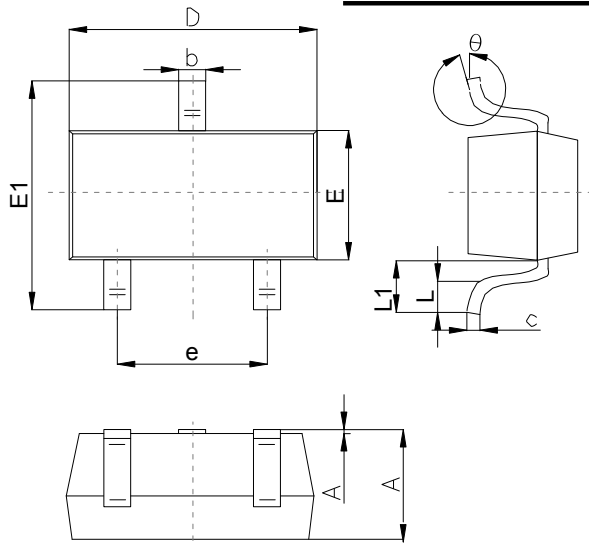

Symbol	Dimensions In Millimeters		
	Min	Typ	Max
A	0.89	1.00	1.40
A1	0.01	0.06	0.10
b	0.37	0.44	0.50
c	0.09	0.13	0.20
D	2.80	2.90	3.10
E	1.20	1.30	1.60
E1	2.10	2.40	2.80
e	1.78	1.90	2.04
L	0.10		0.30
L1	0.35	0.54	0.69
θ	0°		10°

Suggested Pad Layout

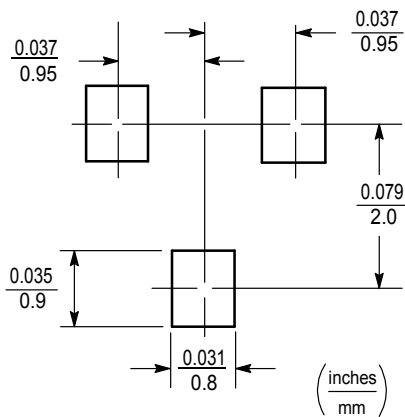

Note:

1. Controlling dimension:in/millimeters.
2. General tolerance: $\pm 0.05\text{mm}$.
3. The pad layout is for reference purposes only.

SOT-23 Tape and Reel

SOT-23 Embossed Carrier Tape

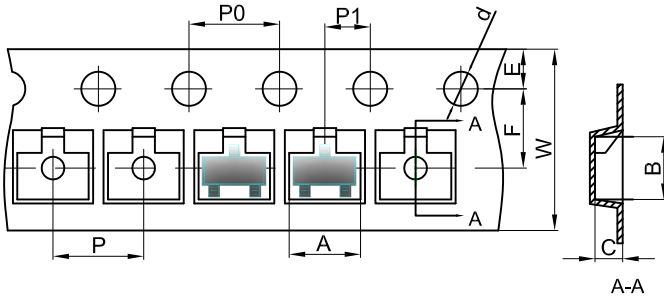

Packaging Description:

SOT-23 parts are shipped in tape. The carrier tape is made from a dissipative (carbon filled) polycarbonate resin. The cover tape is a multilayer film (Heat Activated Adhesive in nature) primarily composed of polyester film, adhesive layer, sealant, and anti-static sprayed agent. These reeled parts in standard option are shipped with 3,000 units per 7" or 17.8cm diameter reel. The reels are clear in color and is made of polystyrene plastic (anti-static coated).

Dimensions are in millimeter										
Pkg type	A	B	C	d	E	F	P0	P	P1	W
SOT-23	3.15	2.77	1.22	Ø1.50	1.75	3.50	4.00	4.00	2.00	8.00

SOT-23 Tape Leader and Trailer

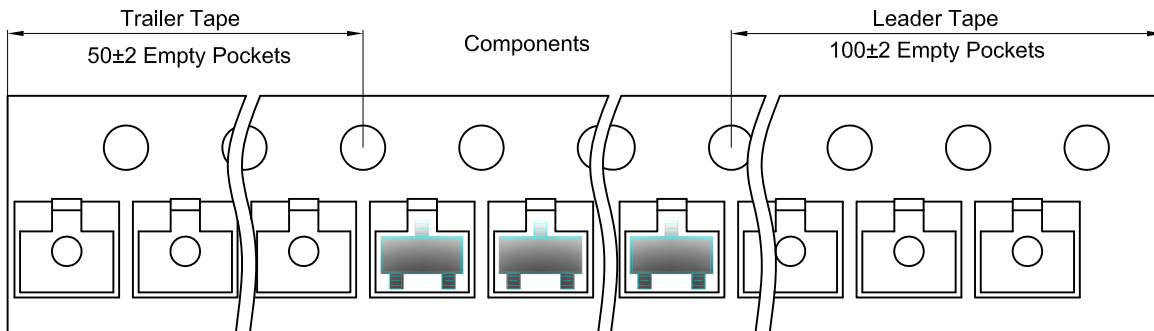

SOT-23 Reel

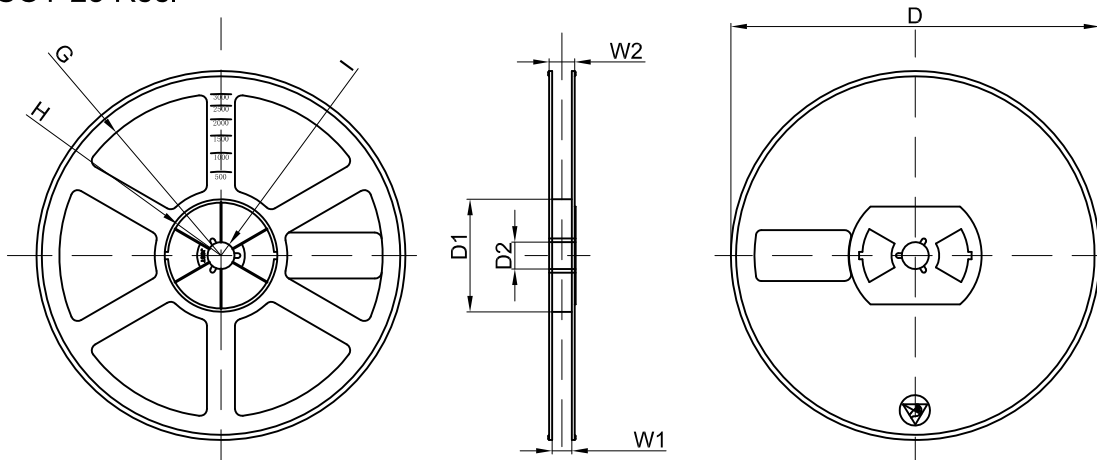

Dimensions are in millimeter								
Reel Option	D	D1	D2	G	H	I	W1	W2
7" Dia	Ø178.00	54.40	13.00	R78.00	R25.60	R6.50	9.50	12.30

REEL	Reel Size	Box	Box Size(mm)	Carton	Carton Size(mm)	G.W.(kg)
3000 pcs	7 Inch	45,000 pcs	203×203×195	180,000 pcs	438×438×220	