

## Features

- Normal capacitance:  $C_{1,2\text{ to }3}=75\text{pF}(\text{Max.})$
- Protects two -7V to +12V lines
- Low leakage current
- IEC 61000-4-2 (ESD Air):  $\pm 30\text{kV}$
- IEC 61000-4-2 (ESD Contact):  $\pm 30\text{kV}$
- IEC 61000-4-5 (Lightning 8/20 $\mu\text{s}$ ): 12A

## Applications

- Protection of RS-485 transceivers with extended common-mode range
- Security systems
- Automatic teller machines
- HFC systems
- Net works

## Maximum Ratings (Ta=25°C Unless otherwise specified)

SYMBOL	PARAMETER	CONDITIONS	VALUE	UNIT
$V_{\text{ESD}}$	Electrostatic Discharge Voltage	ESD per IEC 61000-4-2(Air)	$\pm 30$	KV
		ESD per IEC 61000-4-2(Contact)	$\pm 30$	KV
$P_{\text{PP}}$	Peak Pulse Power	$t_p = 8/20 \mu\text{s}$	300	W
$I_{\text{PP}}$	Rated Peak Pulse Current	$t_p = 8/20 \mu\text{s}$	12	A
$T_J$	Operating Junction Temperature Range	—	-55 to +125	°C
$T_{\text{STG}}$	Storage Temperature Range	—	-55 to +150	°C

## SOT-23

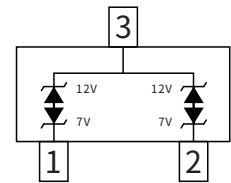
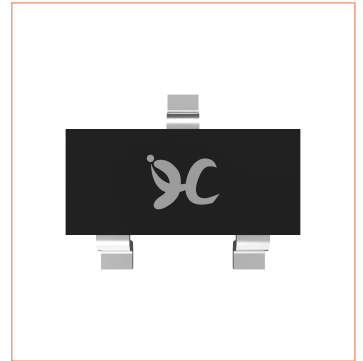

## Electrical Parameter

SYMBOL	PARAMETER
$V_C$	Clamping Voltage @ $I_{\text{PP}}$
$V_{\text{BR}}$	Breakdown Voltage @ $I_T$
$I_{\text{PP}}$	Peak Pulse Current
$I_T$	Test Current
$I_R$	Reverse Leakage Current @ $V_{\text{RWM}}$
$V_{\text{RWM}}$	Peak Reverse Working Voltage
$P_{\text{PP}}$	Peak Pulse Power Dissipation
$C_J$	Junction Capacitance @ $V_R=0\text{V}, f=1\text{MHz}$

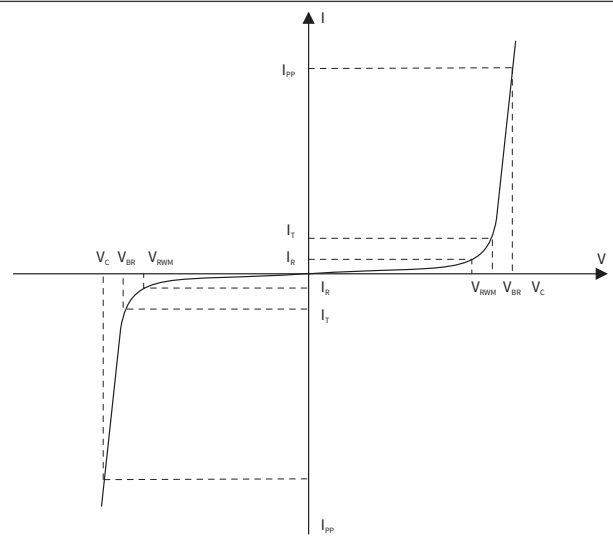

**► Electrical Characteristics** (Ta=25°C Unless otherwise specified)

PARAMETER	SYMBOL	CONDITION	Pins 1/2 to 3 (12V)			Pins 3 to 1/2 (7V)			UNIT
			Min	Typ	Max	Min	Typ	Max	
Peak Reverse Working Voltage	$V_{RWM}$	$T_a=25^\circ\text{C}$	-	-	12	-	-	7	V
Breakdown Voltage	$V_{BR}$	$I_T=1\text{mA}, T_a=25^\circ\text{C}$	13.3	-	-	7.5	-	-	V
Reverse Leakage Current	$I_R$	$V_R=V_{RWM}, T_a=25^\circ\text{C}$	-	-	1.0	-	-	1.0	$\mu\text{A}$
Clamping Voltage	$V_C$	$I_{pp}=1.0\text{A}, t_p=8/20\mu\text{s}$	-	-	15	-	-	8	V
		$I_{pp}=12.0\text{A}, t_p=8/20\mu\text{s}$	-	23	26	-	15	18	V
Junction Capacitance	$C_J$	$V_R=0\text{V}, f=1\text{MHz}$	-	-	75	-	-	75	pF
		$V_R=V_{RWM}, f=1\text{MHz}$	-	45	-	-	45	-	pF

**► Ordering Information**

PREFERRED P/N	PACKAGE	SIZE(mm)	DELIVERY MODE	MPQ(PCS)
SM712	SOT-23	2.90×2.40×1.025	7" REEL	3000

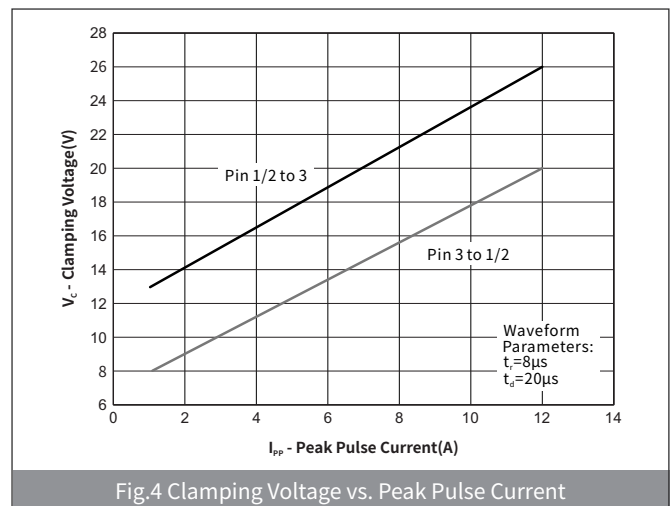
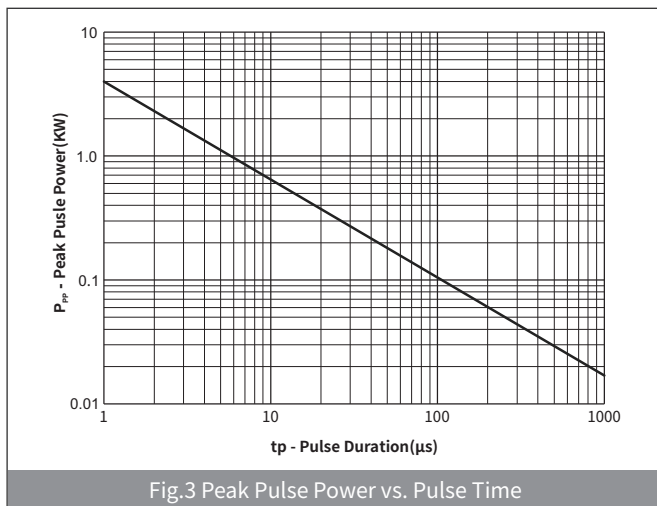
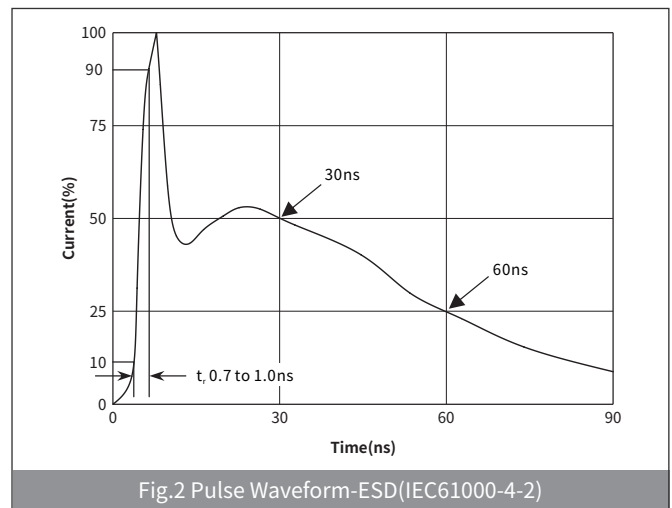
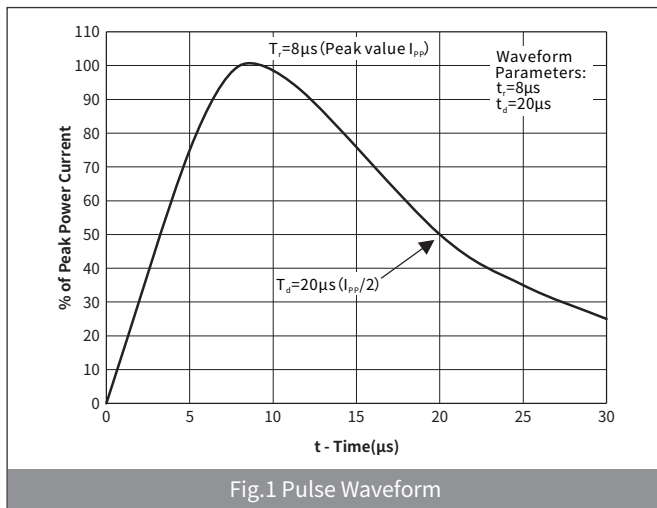
**► Ratings And Characteristics Curves** (Ta=25°C Unless otherwise specified)

### ► Recommended Soldering Conditions

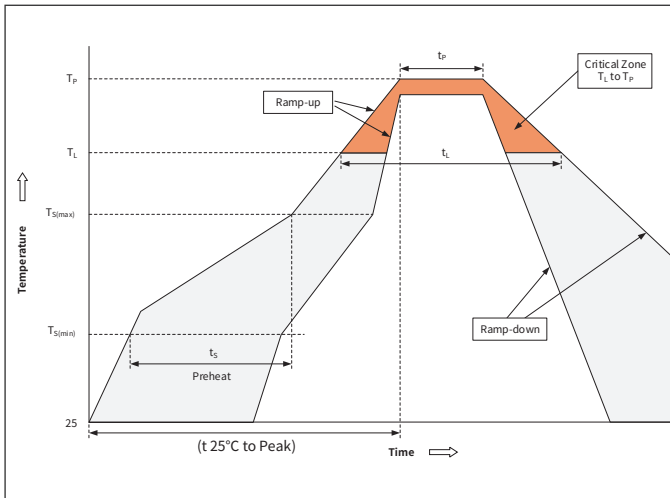

Profile Feature		Pb-Free Assembly
Pre-heat	Temperature Min ( $T_{S(min)}$ )	+150°C
	Temperature Max ( $T_{S(max)}$ )	+200°C
	Time (Min to Max) ( $t_s$ )	60-180 secs.
Average ramp up rate (Liquid us Temp ( $T_L$ ) to peak)		3°C /sec. Max
$T_{S(max)}$ to $T_L$ - Ramp-up Rate		3°C /sec. Max
Reflow	Temperature( $T_L$ )(Liquid us)	+217°C
	Temperature( $t_L$ )	60-150 secs.
Peak Temp ( $T_P$ )		+260(+0/-5)°C
Time within 5°C of actual Peak Temp ( $t_p$ )		30 secs. Max
Ramp-down Rate		6°C /sec. Max
Time 25°C to Peak Temp ( $T_P$ )		8 min. Max
Do not exceed		+260°C

### ► Package Outline Dimensions (SOT-23)

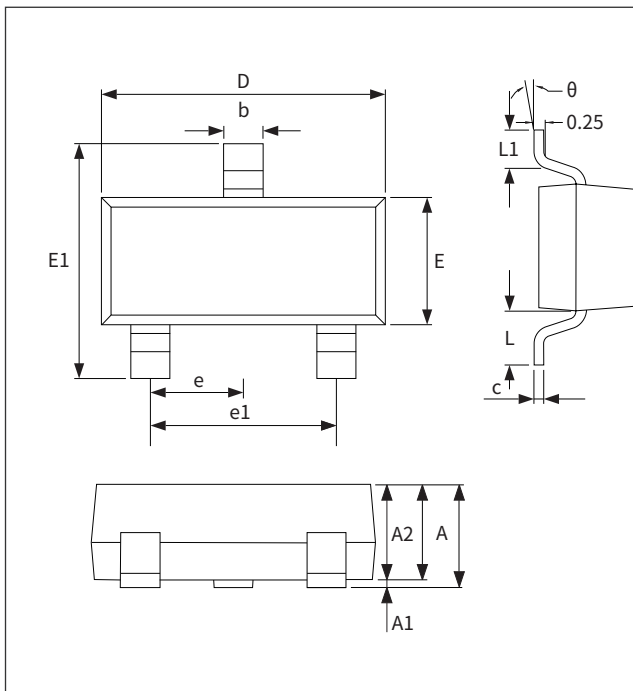

Symbol	Dimensions			
	Millimeters		Inches	
	Min.	Max.	Min.	Max.
A	0.90	1.15	0.035	0.045
A1	-	0.10	-	0.004
A2	0.90	1.05	0.035	0.041
b	0.30	0.50	0.012	0.020
c	0.10	0.20	0.004	0.008
D	2.80	3.00	0.110	0.118
E	1.20	1.40	0.047	0.055
E1	2.25	2.55	0.089	0.100
e	0.950TYP		0.037TYP	
e1	1.80	2.00	0.071	0.079
L	0.550REF		0.022REF	
L1	0.30	0.50	0.012	0.020
$\theta$	-	8°	-	8°

### ► Suggested Pad Layout

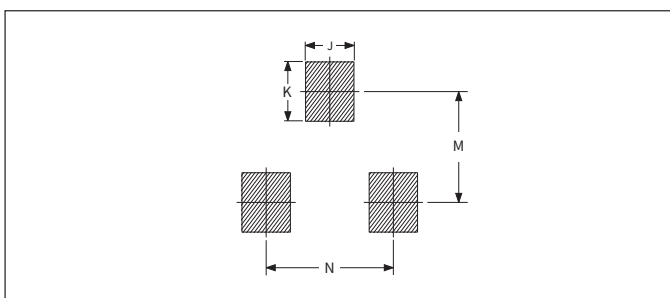

Symbol	Dimensions			
	Millimeters		Inches	
	Min.	Max.	Min.	Max.
J	0.80	-	0.031	-
K	-	0.90	-	0.035
M	2.00	-	0.078	-
N	-	1.90	-	0.074

Note :

This soldering footprint is for reference purposes only. Please consult your manufacturing group to ensure your PCB design guidelines are met.