



# **AiP74LVC3G34 Triple Buffer**

## **Product Specification**

**Specification Revision History:**

<b>Version</b>	<b>Date</b>	<b>Description</b>
2017-04-A1	2017-04	New
2021-12-A2	2021-12	Modify ordering information
2022-02-A3	2022-02	Modify ambient temperature to $-40^{\circ}\text{C}\sim+105^{\circ}\text{C}$ and add electrical characteristics of $-40^{\circ}\text{C}\sim+105^{\circ}\text{C}$
2022-03-A4	2022-03	Modify ordering information note 1



## 1、 General Description

The AiP74LVC3G34 provides three buffers.

The inputs can be driven from either 3.3V or 5V devices. This feature allows the use of the AiP74LVC3G34 as a translator in a mixed 3.3V and 5V environment.

This device is fully specified for partial power-down applications using  $I_{OFF}$ . The  $I_{OFF}$  circuitry disables the output, preventing a damaging backflow current through the device when it is powered down.

### Features:

- Wide supply voltage range from 1.65V to 5.5V
- 5V tolerant input/output for interfacing with 5V logic
- $\pm 24\text{mA}$  output drive ( $V_{CC}=3.0\text{V}$ )
- CMOS low power consumption
- Direct interface with TTL levels
- Specified from  $-40^{\circ}\text{C}$  to  $+105^{\circ}\text{C}$
- Packaging information:TSSOP8/VSSOP8

### Ordering Information:

#### Reel packing specifications:

Part number	Packaging form	Marking code	Reel quantity	Boxed reel quantity	Notes
AiP74LVC3G34TA8.TR	TSSOP8	DCXX	3000 PCS/reel	6000 PCS/box	Dimensions of plastic enclosure: 3.0mm×3.0mm Pin spacing:0.65mm
AiP74LVC3G34YA8.TR	VSSOP8	DCXX	3000 PCS/reel	3000 PCS/box	Dimensions of plastic enclosure: 2.0mm×2.3mm Pin spacing:0.50mm

Note 1: "XX" refers to variable content, meaning year and package batch serial number.

Note 2: If the physical information is inconsistent with the ordering information, please refer to the actual product.



## 2、Block Diagram And Pin Description

### 2.1、Block Diagram

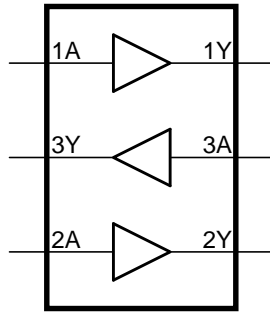

Figure 1. Logic symbol

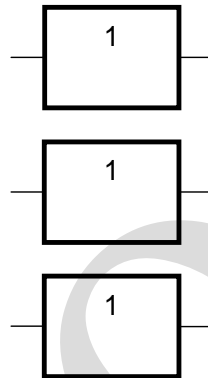
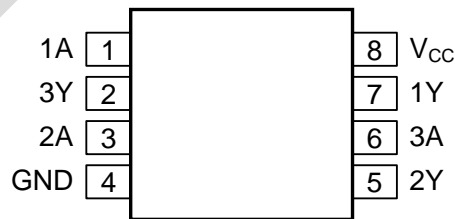

Figure 2. IEC logic symbol



Figure 3. Logic diagram (one gate)

### 2.2、Pin Configurations





## 2.3、Pin Description

Pin No.	Pin Name	Description
1	1A	data input
2	3Y	data output
3	2A	data input
4	GND	ground (0V)
5	2Y	data output
6	3A	data input
7	1Y	data output
8	V <sub>CC</sub>	supply voltage

## 2.4、Function Table

Input	Output
nA	nY
L	L
H	H

Note: H=HIGH voltage level; L=LOW voltage level

## 3、Electrical Parameter

### 3.1、Absolute Maximum Ratings

(T<sub>amb</sub>=25°C, All voltage referenced to GND, unless otherwise specified)

Parameter	Symbol	Conditions	Min.	Max.	Unit
supply voltage	V <sub>CC</sub>	-	-0.5	+6.5	V
input clamping current	I <sub>IK</sub>	V <sub>I</sub> <0V	-50	-	mA
input voltage	V <sub>I</sub>	- <sup>[1]</sup>	-0.5	+6.5	V
output clamping current	I <sub>OK</sub>	V <sub>O</sub> >V <sub>CC</sub> or V <sub>O</sub> <0V	-	±50	mA
output voltage	V <sub>O</sub>	Active mode <sup>[1]</sup>	-0.5	V <sub>CC</sub> +0.5	V
		Power-down mode <sup>[1]</sup>	-0.5	+6.5	V
output current	I <sub>O</sub>	V <sub>O</sub> =0V to V <sub>CC</sub>	-	±50	mA
supply current	I <sub>CC</sub>	-	-	100	mA
ground current	I <sub>GND</sub>	-	-100	-	mA
storage temperature	T <sub>stg</sub>	-	-65	+150	°C
total power dissipation	P <sub>tot</sub>	- <sup>[2]</sup>	-	250	mW
soldering temperature	T <sub>L</sub>	10s		250	°C

Note:

[1] The minimum input and output voltage ratings may be exceeded if the input and output current ratings are observed.

[2] For TSSOP8 package: above 55°C the value of P<sub>tot</sub> derates linearly with 2.5mW/K.

For VSSOP8 package: above 110°C the value of P<sub>tot</sub> derates linearly with 8mW/K.



## 3.2、Recommended Operating Conditions

Parameter	Symbol	Conditions	Min.	Typ.	Max.	Unit
supply voltage	$V_{CC}$	-	1.65	-	5.5	V
input voltage	$V_I$	-	0	-	5.5	V
output voltage	$V_O$	Active mode	0	-	$V_{CC}$	V
		Power-down mode; $V_{CC}=0V$	0	-	5.5	V
ambient temperature	$T_{amb}$	-	-40	-	+105	°C
input transition rise and fall rate	$\Delta t/\Delta V$	$V_{CC}=1.65V$ to $2.7V$	-	-	20	ns/V
		$V_{CC}=2.7V$ to $5.5V$	-	-	10	ns/V

## 3.3、Electrical Characteristics

### 3.3.1、DC Characteristics 1

( $T_{amb}=-40^{\circ}C$  to  $+85^{\circ}C$ , voltages are referenced to GND (ground=0V), unless otherwise specified.)

Parameter	Symbol	Conditions	Min.	Typ. <sup>[1]</sup>	Max.	Unit	
HIGH-level input voltage	$V_{IH}$	$V_{CC}=1.65V$ to $1.95V$	$0.65 \times V_{CC}$	-	-	V	
		$V_{CC}=2.3V$ to $2.7V$	1.7	-	-	V	
		$V_{CC}=2.7V$ to $3.6V$	2.0	-	-	V	
		$V_{CC}=4.5V$ to $5.5V$	$0.7 \times V_{CC}$	-	-	V	
LOW-level input voltage	$V_{IL}$	$V_{CC}=1.65V$ to $1.95V$	-	-	$0.35 \times V_{CC}$	V	
		$V_{CC}=2.3V$ to $2.7V$	-	-	0.7	V	
		$V_{CC}=2.7V$ to $3.6V$	-	-	0.8	V	
		$V_{CC}=4.5V$ to $5.5V$	-	-	$0.3 \times V_{CC}$	V	
HIGH-level output voltage	$V_{OH}$	$V_I=V_{IH}$ or $V_{IL}$	$I_O=-100\mu A$ ; $V_{CC}=1.65V$ to $5.5V$	$V_{CC}-0.1$	-	-	V
			$I_O=-4mA$ ; $V_{CC}=1.65V$	1.2	-	-	V
			$I_O=-8mA$ ; $V_{CC}=2.3V$	1.9	-	-	V
			$I_O=-12mA$ ; $V_{CC}=2.7V$	2.2	-	-	V
			$I_O=-24mA$ ; $V_{CC}=3.0V$	2.3	-	-	V
			$I_O=-32mA$ ; $V_{CC}=4.5V$	3.8	-	-	V
LOW-level output voltage	$V_{OL}$	$V_I=V_{IH}$ or $V_{IL}$	$I_O=100\mu A$ ; $V_{CC}=1.65V$ to $5.5V$	-	-	0.10	V
			$I_O=4mA$ ; $V_{CC}=1.65V$	-	-	0.45	V
			$I_O=8mA$ ; $V_{CC}=2.3V$	-	-	0.30	V
			$I_O=12mA$ ; $V_{CC}=2.7V$	-	-	0.40	V
			$I_O=24mA$ ; $V_{CC}=3.0V$	-	-	0.55	V
			$I_O=32mA$ ; $V_{CC}=4.5V$	-	-	0.55	V
input leakage current	$I_I$	$V_I=5.5V$ or GND; $V_{CC}=0V$ to $5.5V$	-	$\pm 0.1$	$\pm 1$	$\mu A$	
power-off leakage current	$I_{OFF}$	$V_I$ or $V_O=5.5V$ ; $V_{CC}=0V$	-	$\pm 0.1$	$\pm 2$	$\mu A$	



supply current	$I_{CC}$	$V_I=5.5V$ or GND; $I_O=0A$ ; $V_{CC}=1.65V$ to $5.5V$	-	0.1	4	$\mu A$
additional supply current	$\Delta I_{CC}$	per pin; $V_I=V_{CC}-0.6V$ ; $I_O=0A$ ; $V_{CC}=2.3V$ to $5.5V$	-	5	500	$\mu A$
input capacitance	$C_I$	$V_{CC}=3.3V$ ; $V_I=GND$ to $V_{CC}$	-	2.5	-	pF

Note: All typical values are measured at  $V_{CC}=3.3V$  and  $T_{amb}=25^\circ C$ .

### 3.3.2、DC Characteristics 2

( $T_{amb}=-40^\circ C$  to  $+105^\circ C$ , voltages are referenced to GND (ground=0V), unless otherwise specified.)

Parameter	Symbol	Conditions	Min.	Typ. <sup>[1]</sup>	Max.	Unit	
HIGH-level input voltage	$V_{IH}$	$V_{CC}=1.65V$ to $1.95V$	$0.65 \times V_{CC}$	-	-	V	
		$V_{CC}=2.3V$ to $2.7V$	1.7	-	-	V	
		$V_{CC}=2.7V$ to $3.6V$	2.0	-	-	V	
		$V_{CC}=4.5V$ to $5.5V$	$0.7 \times V_{CC}$	-	-	V	
LOW-level input voltage	$V_{IL}$	$V_{CC}=1.65V$ to $1.95V$	-	-	$0.35 \times V_{CC}$	V	
		$V_{CC}=2.3V$ to $2.7V$	-	-	0.7	V	
		$V_{CC}=2.7V$ to $3.6V$	-	-	0.8	V	
		$V_{CC}=4.5V$ to $5.5V$	-	-	$0.3 \times V_{CC}$	V	
HIGH-level output voltage	$V_{OH}$	$V_I=V_{IH}$ or $V_{IL}$	$I_O=-100\mu A$ ; $V_{CC}=1.65V$ to $5.5V$	$V_{CC}-0.1$	-	-	V
			$I_O=-4mA$ ; $V_{CC}=1.65V$	0.95	-	-	V
			$I_O=-8mA$ ; $V_{CC}=2.3V$	1.7	-	-	V
			$I_O=-12mA$ ; $V_{CC}=2.7V$	1.9	-	-	V
			$I_O=-24mA$ ; $V_{CC}=3.0V$	2.0	-	-	V
			$I_O=-32mA$ ; $V_{CC}=4.5V$	3.4	-	-	V
LOW-level output voltage	$V_{OL}$	$V_I=V_{IH}$ or $V_{IL}$	$I_O=100\mu A$ ; $V_{CC}=1.65V$ to $5.5V$	-	-	0.10	V
			$I_O=4mA$ ; $V_{CC}=1.65V$	-	-	0.70	V
			$I_O=8mA$ ; $V_{CC}=2.3V$	-	-	0.45	V
			$I_O=12mA$ ; $V_{CC}=2.7V$	-	-	0.60	V
			$I_O=24mA$ ; $V_{CC}=3.0V$	-	-	0.80	V
			$I_O=32mA$ ; $V_{CC}=4.5V$	-	-	0.80	V
input leakage current	$I_I$	$V_I=5.5V$ or GND; $V_{CC}=0V$ to $5.5V$	-	-	$\pm 1$	$\mu A$	
power-off leakage current	$I_{OFF}$	$V_I$ or $V_O=5.5V$ ; $V_{CC}=0V$	-	-	$\pm 2$	$\mu A$	
supply current	$I_{CC}$	$V_I=5.5V$ or GND; $I_O=0A$ ; $V_{CC}=1.65V$ to $5.5V$	-	-	4	$\mu A$	
additional supply current	$\Delta I_{CC}$	per pin; $V_I=V_{CC}-0.6V$ ; $I_O=0A$ ; $V_{CC}=2.3V$ to $5.5V$	-	-	500	$\mu A$	



Note: All typical values are measured at  $V_{CC}=3.3V$  and  $T_{amb}=25^{\circ}C$ .

### 3.3.3、AC Characteristics 1

( $T_{amb}=-40^{\circ}C$  to  $+85^{\circ}C$ , voltages are referenced to GND (ground=0V), unless otherwise specified.)

Parameter	Symbol	Conditions	Min.	Typ. <sup>[1]</sup>	Max.	Unit	
nA to nY propagation delay	$t_{pd}$	see Figure 5 <sup>[2]</sup>	$V_{CC}=1.65V$ to $1.95V$	1.0	3.8	8.6	ns
			$V_{CC}=2.3V$ to $2.7V$	0.5	2.4	4.4	ns
			$V_{CC}=2.7V$	0.5	2.5	5.0	ns
			$V_{CC}=3.0V$ to $3.6V$	0.5	2.2	4.1	ns
			$V_{CC}=4.5V$ to $5.5V$	0.5	1.9	3.2	ns
power dissipation capacitance	$C_{PD}$	$V_{CC}=3.3V$ ; $V_I=GND$ to $V_{CC}$ <sup>[3]</sup>	-	14	-	pF	

Note:

[1] Typical values are measured at  $T_{amb}=25^{\circ}C$  and  $V_{CC}=1.8V$ ,  $2.5V$ ,  $2.7V$ ,  $3.3V$  and  $5.0V$  respectively.

[2]  $t_{pd}$  is the same as  $t_{PLH}$  and  $t_{PHL}$ .

[3]  $C_{PD}$  is used to determine the dynamic power dissipation ( $P_D$  in uW).

$$P_D=C_{PD}\times V_{CC}^2\times f_i\times N+\sum(C_L\times V_{CC}^2\times f_o)$$
 where:

$f_i$ =input frequency in MHz;

$f_o$ =output frequency in MHz;

$C_L$ =output load capacitance in pF;

$V_{CC}$ =supply voltage in V;

$N$ =number of inputs switching;

$\sum(C_L\times V_{CC}^2\times f_o)$ =sum of outputs.

### 3.3.4、AC Characteristics 2

( $T_{amb}=-40^{\circ}C$  to  $+105^{\circ}C$ , voltages are referenced to GND (ground=0V), unless otherwise specified.)

Parameter	Symbol	Conditions	Min.	Typ. <sup>[1]</sup>	Max.	Unit	
nA to nY propagation delay	$t_{pd}$	see Figure 5 <sup>[2]</sup>	$V_{CC}=1.65V$ to $1.95V$	1.0	-	10.8	ns
			$V_{CC}=2.3V$ to $2.7V$	0.5	-	5.5	ns
			$V_{CC}=2.7V$	0.5	-	6.3	ns
			$V_{CC}=3.0V$ to $3.6V$	0.5	-	5.1	ns
			$V_{CC}=4.5V$ to $5.5V$	0.5	-	4.0	ns

Note:

[1] Typical values are measured at  $T_{amb}=25^{\circ}C$  and  $V_{CC}=1.8V$ ,  $2.5V$ ,  $2.7V$ ,  $3.3V$  and  $5.0V$  respectively.

[2]  $t_{pd}$  is the same as  $t_{PLH}$  and  $t_{PHL}$ .



## 4、 Testing Circuit

### 4.1、 AC Testing Circuit

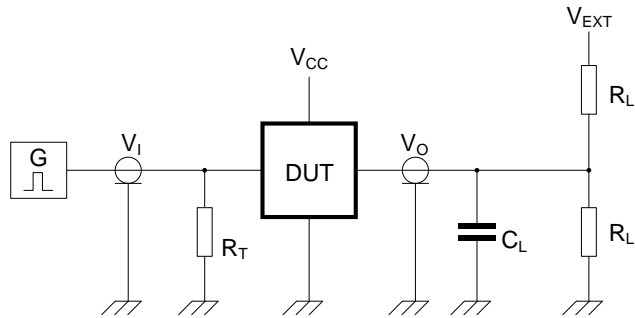

Figure 4. Test circuit for measuring switching times

Definitions for test circuit:

$R_L$ =Load resistance.

$C_L$ =Load capacitance including jig and probe capacitance.

$R_T$ =Termination resistance; should be equal to the output impedance  $Z_o$  of the pulse generator.

$V_{EXT}$ =External voltage for measuring switching times.

### 4.2、 AC Testing Waveforms

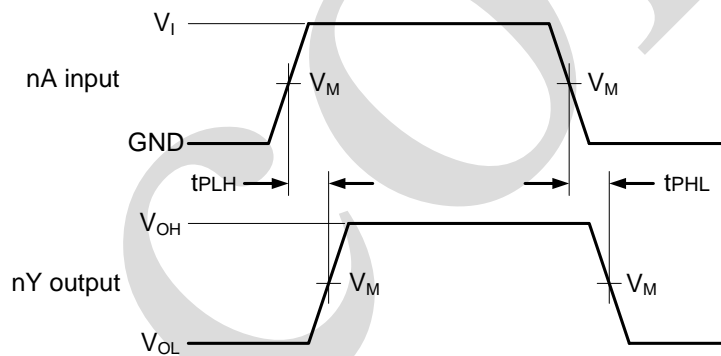

Figure 5. The input nA to output nY propagation delays





### 4.3、Measurement Points

Supply voltage	Input	Output
$V_{CC}$	$V_M$	$V_M$
1.65V to 1.95V	$0.5 \times V_{CC}$	$0.5 \times V_{CC}$
2.3V to 2.7V	$0.5 \times V_{CC}$	$0.5 \times V_{CC}$
2.7V	1.5V	1.5V
3.0V to 3.6V	1.5V	1.5V
4.5V to 5.5V	$0.5 \times V_{CC}$	$0.5 \times V_{CC}$

### 4.4、Test Data

Supply voltage	Input		Load		$V_{EXT}$
	$V_I$	$t_r=t_f$	$C_L$	$R_L$	$t_{PLH}, t_{PHL}$
1.65V to 1.95V	$V_{CC}$	$\leq 2.0ns$	30pF	1k $\Omega$	open
2.3V to 2.7V	$V_{CC}$	$\leq 2.0ns$	30pF	500 $\Omega$	open
2.7V	2.7V	$\leq 2.5ns$	50pF	500 $\Omega$	open
3.0V to 3.6V	2.7V	$\leq 2.5ns$	50pF	500 $\Omega$	open
4.5V to 5.5V	$V_{CC}$	$\leq 2.5ns$	50pF	500 $\Omega$	open



5、 Package Information

5.1、 TSSOP8

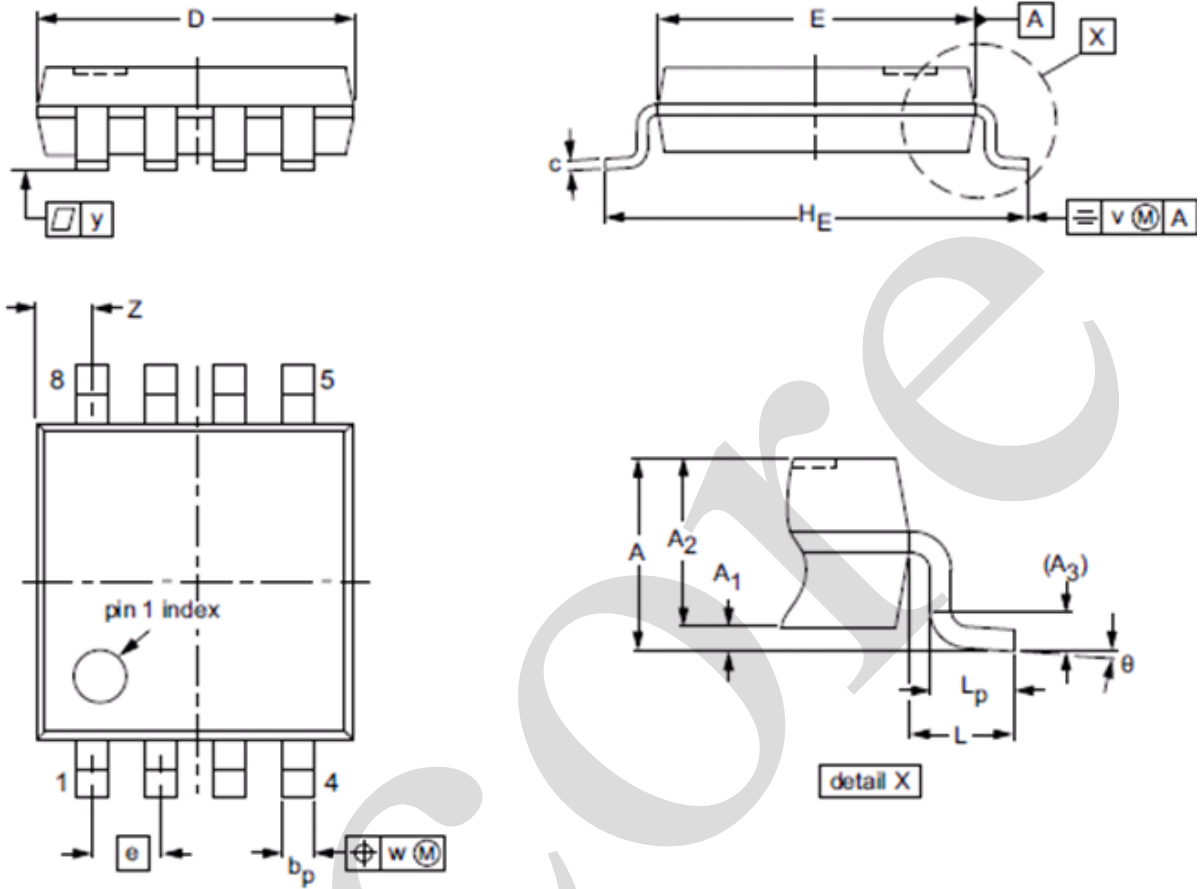

UNIT	A max.	A <sub>1</sub>	A <sub>2</sub>	A <sub>3</sub>	b <sub>p</sub>	c	D <sup>(1)</sup>	E <sup>(1)</sup>	e	H <sub>E</sub>	L	L <sub>p</sub>	v	w	y	Z <sup>(1)</sup>	θ
mm	1.1	0.15 0.00	0.95 0.75	0.25	0.38 0.22	0.18 0.08	3.1 2.9	3.1 2.9	0.65	4.1 3.9	0.5	0.47 0.33	0.2	0.13	0.1	0.70 0.35	8° 0°



## 5.2、VSSOP8

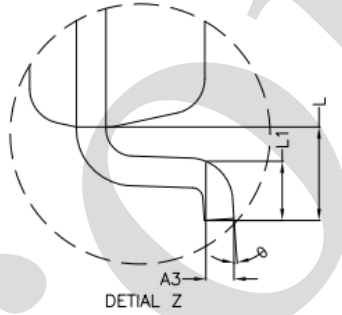
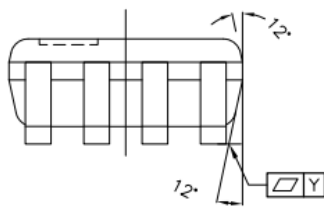
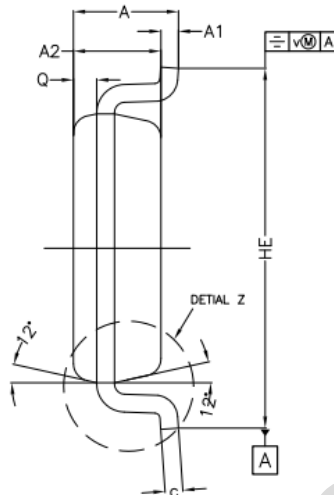
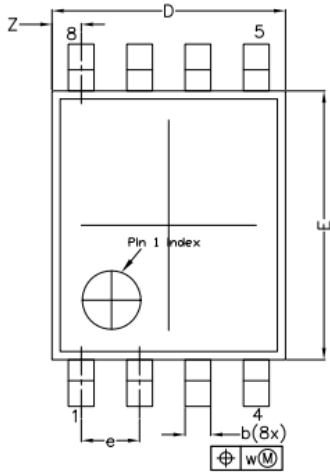

\* CONTROLLING DIMENSION : MM

SYMBOL	MILLIMETER		
	MIN.	NOM.	MAX.
A	---	---	1.00
A1	0.00	---	0.15
A2	0.60	0.75	0.85
A3	---	0.12	---
Q	0.19	0.20	0.21
b	0.17	0.22	0.27
c	0.08	---	0.23
D	1.90	2.00	2.10
E	2.20	2.30	2.40
HE	3.00	3.10	3.20
e	0.50 bsc		
L	0.40 bsc		
L1	0.15	---	0.40
Y	---	0.10	---
v	---	0.20	---
w	---	0.08	---
Z	0.10	---	0.40
θ	0°	---	8°

### NOTES

1.0 COPLANARITY APPLIES TO LEADS, CORNER LEADS AND DIE ATTACH PAD.



## 6、 Statements And Notes

### 6.1、 The name and content of Hazardous substances or Elements in the product

Part name	Hazardous substances or Elements									
	Lead and lead compounds	Mercury and mercury compounds	Cadmium and cadmium compounds	Hexavalent chromium compounds	Polybrominated biphenyls	Polybrominated biphenyl ethers	Dibutyl phthalate	Butylbenzyl phthalate	Di-2-ethylhexyl phthalate	Diisobutyl phthalate
Lead frame	○	○	○	○	○	○	○	○	○	○
Plastic resin	○	○	○	○	○	○	○	○	○	○
Chip	○	○	○	○	○	○	○	○	○	○
The lead	○	○	○	○	○	○	○	○	○	○
Plastic sheet installed	○	○	○	○	○	○	○	○	○	○
explanation	○: Indicates that the content of hazardous substances or elements in the detection limit of the following the SJ/T11363-2006 standard. ×: Indicates that the content of hazardous substances or elements exceeding the SJ/T11363-2006 Standard limit requirements.									

### 6.2、 Notion

Recommended carefully reading this information before the use of this product;

The information in this document are subject to change without notice;

This information is using to the reference only, the company is not responsible for any loss;

The company is not responsible for the any infringement of the third party patents or other rights of the responsibility.