

Specification Sheet for Approved

Customer Name:	
Customer Part No.:	
Ceaiya Part No:	CR8065A Series
Spec No:	L865

【For Customer Approval Only】

If you Approval, Please Stamp

【RoHS Compliant Parts】

Approved By	Checked By	Prepared By
李庆辉	刘志坚	劳水花

Shenzhen Ceaiya Electronics Co., Ltd.

深圳地址 1: 深圳市龙华区观湖街道鹭湖社区观盛二路 5 号捷顺科技中心 B706

东莞地址 2: 广东省东莞清溪镇青滨东路 105 号力合紫荆智能制造中心 10 栋

Http : //www.szceaiya.com

Tel: 0769-89135516

Fax: 0769-89135519

History of change

Rev.	Effective Date	Changed Contents	Change reasons	Approved By
A0	2023-05-25	New release		

1. Shape and Dimension (Unit:mm)

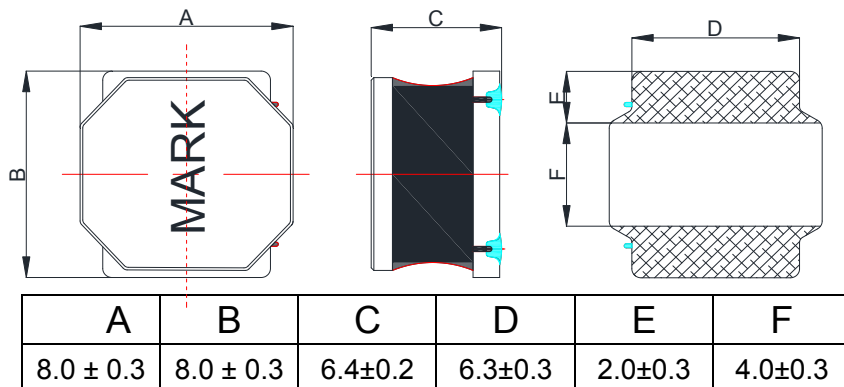

* Dimension without tolerance is approx.

2. Electronic Characteristics List

Part Number	Inductance (uH)	Tolerance (±%)	DCR(mΩ) ±30%	Isat (A)	Irise (A)	Test Condition	Marking
CR8065A-4R7N	4.7	30	18	8.50	4.70	100KHz/0.25V	4R7
CR8065A-6R8M	6.8	20	26	7.60	4.30	100KHz/0.25V	6R8
CR8065A-100M	10	20	33	6.60	4.00	100KHz/0.25V	100
CR8065A-220M	22	20	54	4.30	2.80	100KHz/0.25V	220
CR8065A-330M	33	20	83	3.60	2.00	100KHz/0.25V	330
CR8065A-470M	47	20	135	2.85	1.80	100KHz/0.25V	470
CR8065A-680M	68	20	181	2.50	1.50	100KHz/0.25V	680
CR8065A-820M	82	20	215	2.30	1.40	100KHz/0.25V	820
CR8065A-101M	100	20	250	2.00	1.30	100KHz/0.25V	101
CR8065A-151M	150	20	360	1.60	1.00	100KHz/0.25V	151
CR8065A-221M	220	20	528	1.30	0.90	100KHz/0.25V	221
CR8065A-331M	330	20	850	1.20	0.70	100KHz/0.25V	331
CR8065A-471M	470	20	1300	1.00	0.55	100KHz/0.25V	471
CR8065A-681M	680	20	1800	0.85	0.46	100KHz/0.25V	681
CR8065A-102M	1000	20	2350	0.65	0.40	100KHz/0.25V	102
CR8065A-222M	2200	20	5000	0.45	0.27	100KHz/0.25V	222

注：

1. All test data is referenced to 25°C ambient;
2. Rated current: Isat or Irms, whichever is smaller;
3. Isat: DC current at which the inductance drops approximate 30% from its value without current;
4. Irms: DC current that causes the temperature rise ($\Delta T=40^{\circ}\text{C}$) from 20°C ambient.

Measuring Instrument :

L:HIOKI3532-50

DCR:HIOKI 3540

Isat / Irise: HP4284A+42841

3. General Characteristics

3-1. Storage Temperature range : $-40^{\circ}\text{C} \sim +125^{\circ}\text{C}$

3-2. Operating temperature range: $-40^{\circ}\text{C} \sim +125^{\circ}\text{C}$ (Including coil's self temperature rise)

3-3. External appearance : No external defects can be found in the visual inspection.

3-4. Electrode strength : No electrode detachment should be found when the device is pushed in two directions of X and Y with the force of 10.0N for 10 ± 2 seconds after soldering between copper plate and the electrodes.

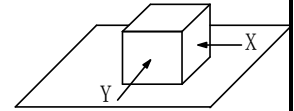

(Refer to figure at right)

3-5. Vibration test : Inductance deviation is within $\pm 10.0\%$ after 1 hour sweeping vibration in each three directions, namely, forward and backward, up and down, right and left. The frequency is $10 \sim 55 \sim 10\text{Hz}$ and the amplitude of 1 minute cycle is 1.5mm PP.

3-6. Recommended reflow condition :

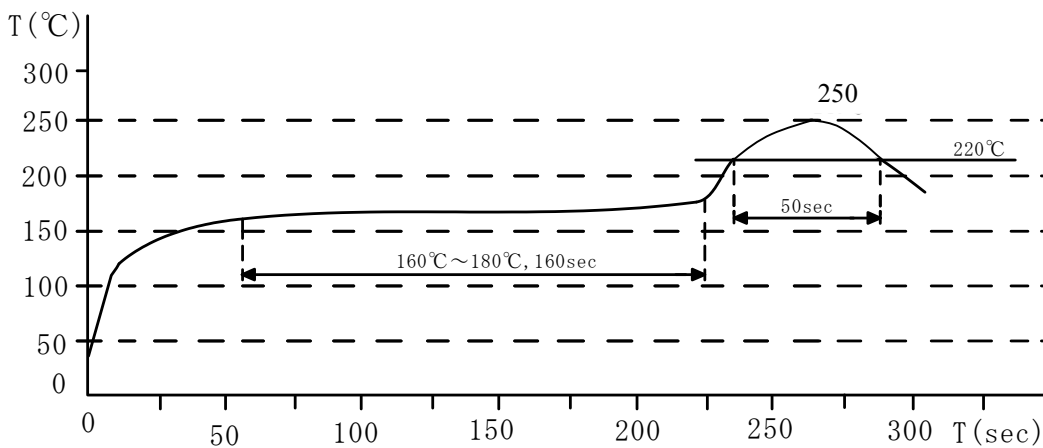

3-7. Humidity test : Inductance deviation is within $\pm 5.0\%$ after 96 ± 4 hours test under the condition of relative humidity of $90 \sim 95\%$ and temperature of $60 \pm 2^{\circ}\text{C}$, and 1 hour storage under room ambient conditions after the device is wiped with dry cloth.

LEAD-FREE



4. Construction

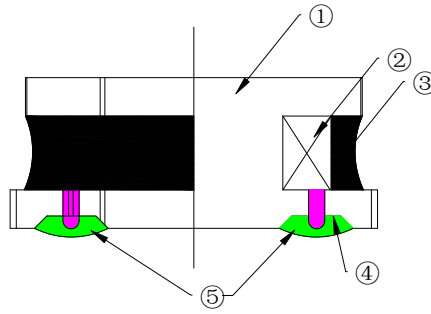

No.	Part name	Material	Manufacturer
①	Drum Core	Ni-Zn Ferrite Core	CY
②	Wire	Polyurethane enameled copper wire	YLSL
③	Adhesive	Epoxy Resin Magnetic Powder	
④	Plating Electrodes	Plating: Ag 3-7 μm Ni 1-3 μm Sn 3-7 μm	
⑤	Outer Electrodes	Top surface solder coating Sn99%、 Ag0.3%、Cu0.7%	YX

5. TAPE DIMENSIONS:

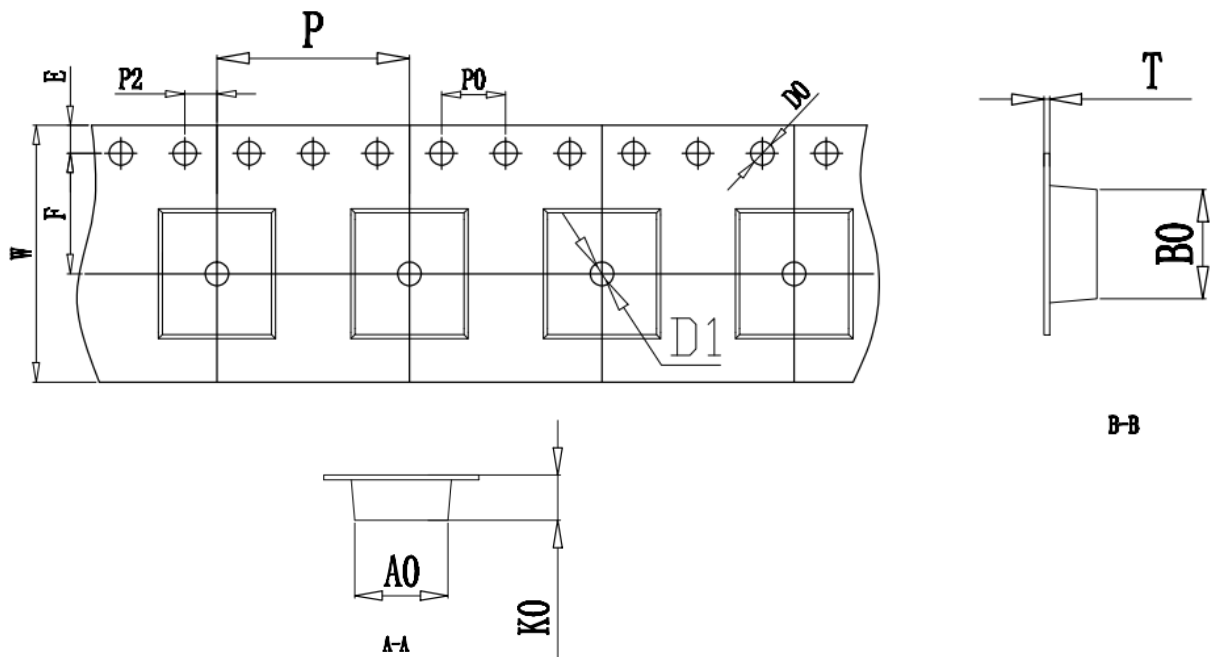

ITEM	W	A0	B0	K0	P	F	E	D0	D1	P0	P2	T
DIM	16.00	8.3	8.3	6.8	12.0	7.50	1.75	1.50	1.50	4.00	2.00	0.40
TOLE	± 0.3	± 0.1	± 0.1	± 0.1	± 0.1	± 0.1	± 0.1	+0.1	+0.1	± 0.1	± 0.1	± 0.05

包装数量：700PCS/卷

6. CARRIER REEL DIMENSIONS:

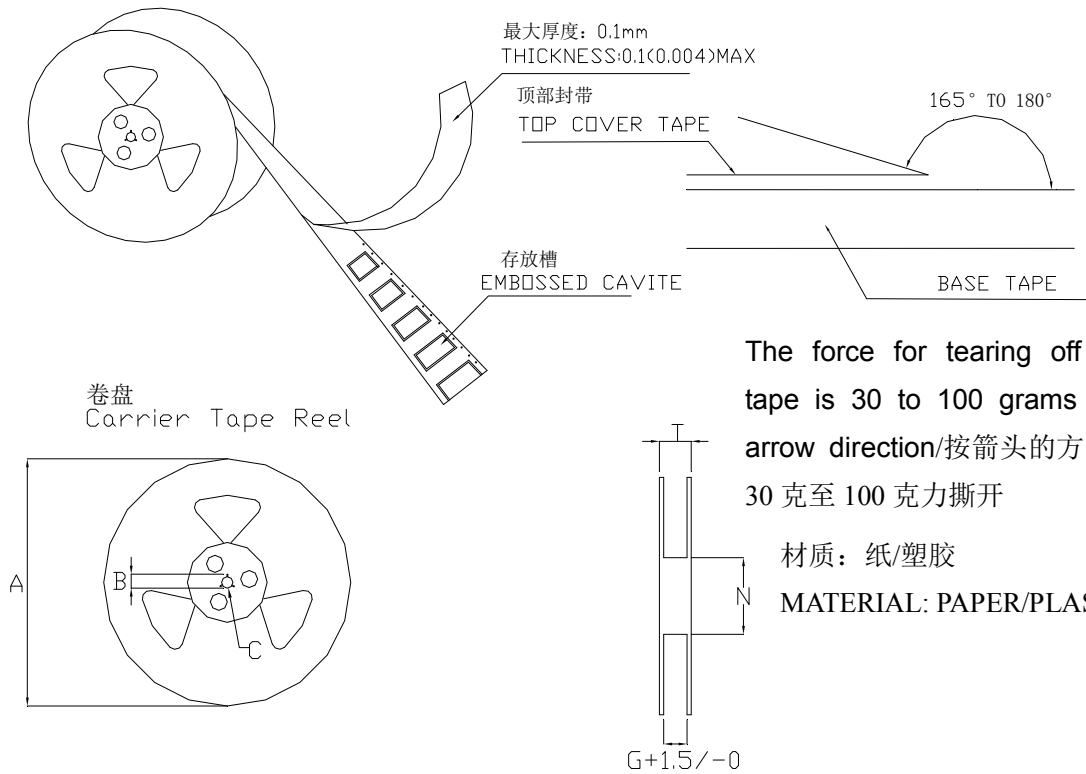

Unit: mm

Type	A	B	C	G	N	T
16mm	330	21±0.8	13±0.4	16.4	100	20.4

7. PACKAGE SPECIFICATION :

700PCS/Reel 2.1KPCS/Inner Box 6.3KPCS/Outer Box

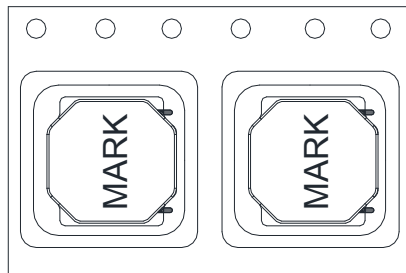

Visual Inspection Standard of Product

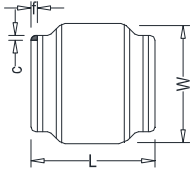
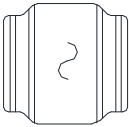
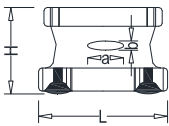
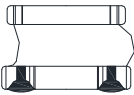
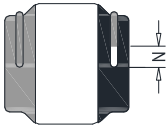
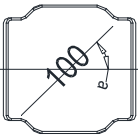
No.	Defect Item	Figure	Rejection Identification	Acceptance
1	Core Defect		The defect length(c or f)more than L/6 or W/6 , NG	AQL=0.65
2	Core Crack		Visual cracks , NG	AQL=0.65
3	Starvation		(1)Resin starved length a more than L/2, NG (2)When L>2mm,b>H/2, NG (3)When L≤2mm, b don't control	AQL=0.65
4	Excessive glue		The length, width or height of product beyond specified value, NG	AQL=0.65
5	Cold Solder		(1)For CR2520** Series , cold solder N>0.5mm,NG (2)For other series, cold solder N>1mm,NG	AQL=0.65
6	Marking Defect		The marking angle a>45° , NG	AQL=0.65

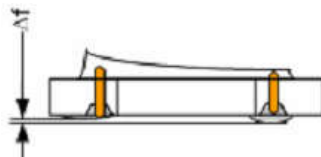

Δf: Clearance between terminal and the surface of plate must be 0.2mm max when coil is placed on a flat plate.