

REV.	ECR/N NO./DESCRIPTION	DATE	DRAWN	CHECKED	APPROVE
1	SN14155	11/17'14	Lxh	Vito	Barney

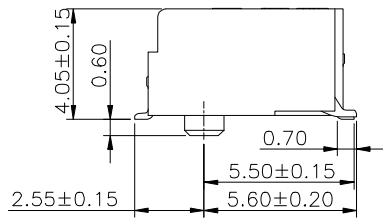

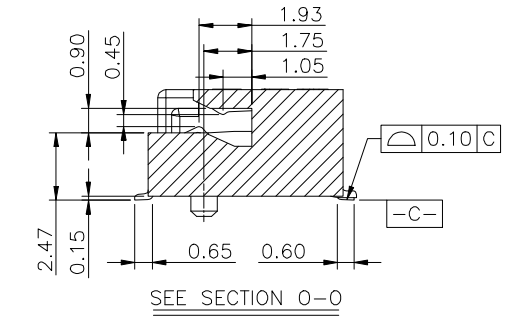

GENERAL TOLERANCES UNLESS SPECIFIED		PART NO.	 Lian Xin Technology		
X ± 0.35	X° ± 3°	SEE TABLE			
XX ± 0.25	X° ± 2°	APPROVED BY	TITLE		
XXX ± 0.15	XX° ± 1°	Barney 11/17'14			
CUSTOMER DRAWING		CHECKED BY	DWG NO.		
		Vito 11/17'14			
SIZE	UNITS	DRAWN BY	 SHEET SCALE REV		
A4	MM [INCH]	Lxh 11/17'14			

TABLE:

NO.	PART NO.	DESCRIPTION	DURABILITY
1	APCI0107-P001A	GOLD G/F ON CONTACT AREA	25 CYCLES
		GOLD G/F ON SOLDER AREA	
2	APCI0107-P002A	GOLD 10u" ON CONTACT AREA	25 CYCLES
		GOLD G/F ON SOLDER AREA	
3	APCI0107-P003A	GOLD 15u" ON CONTACT AREA	25 CYCLES
		GOLD G/F ON SOLDER AREA	
4	APCI0107-P004A	GOLD 30u" ON CONTACT AREA	60 CYCLES
		GOLD G/F ON SOLDER AREA	
5	APCI0107-P005A	GOLD G/F ON CONTACT AREA	25 CYCLES
		80u" MIN. MATTE TIN ON SOLDER AREA	
6	APCI0107-P006A	GOLD 10u" ON CONTACT AREA	25 CYCLES
		80u" MIN. MATTE TIN ON SOLDER AREA	
7	APCI0107-P007A	GOLD 15u" ON CONTACT AREA	25 CYCLES
		80u" MIN. MATTE TIN ON SOLDER AREA	
8	APCI0107-P008A	GOLD 30u" ON CONTACT AREA	60 CYCLES
		80u" MIN. MATTE TIN ON SOLDER AREA	



Notes:

- MATERIAL SPECIFICATION:
 - HOUSING:LCP+40%GF,UL94V-0,COLOR:BLACK.
 - CONTACT:COPPER ALLOY.
 - PEG:STEEL.
- PLATING SPECIFICATION:
 - CONTACT:50u" MIN.NICKEL UNDER PLATING OVER ALL.PLATING ON SOLDER AREA:SEE TABLE GOLD PLATING ON CONTACT AREA:SEE TABLE
 - PEG:50u" MIN. NICKEL UNDER PLATING OVER ALL. 80u" MIN. MATTE TIN PLATING ON SOLDER AREA.
- HF COMPLIANT, RoHS COMPLIANT.
- DATE CODE: XX XX XX
 DAY
 WEEK
 YEAR
- MECHANICAL PERFORMANCE:
 - DURABILITY: SEE TABLE
- ELECTRICAL PERFORMANCE:
 - CURRENT: 0.5A PER PIN.
 - LLCR: INITIAL 55mΩ MAX.;FINAL ΔLLCR=20mΩ MAX.
- IR REFLOW:
 THE TEMPERATURE SHALL BE 260±5°C MAINTAINING 10±1 SECONDS.
- PRODUCT NUMBER NOTE:

APCI XXXX - XXXX XX

FINISHED PRODUCT

CUSTOMER CODE
 PACKING TYPE
 PRODUCT SERIAL NUMBER
 P:HF COMPLIANT
 TYPE SERIAL NUMBER
 PRODUCT TYPE

GENERAL TOLERANCES UNLESS SPECIFIED		PART NO.	 连欣科技 Lian Xin Technology			
X ± 0.35 X ± 3°		SEE TABLE				
XX ± 0.25 X ± 2°		APPROVED BY	TITLE			
XXX ± 0.15 XX ± 1°		Bamey 11/17'14	0.5 PITCH M.2 H4.2 (KEY M)			
CUSTOMER DRAWING		CHECKED BY	DWG NO.			
		Vito 11/17'14	AP-APCI0107			
SIZE	UNITS	DRAWN BY		SHEET	SCALE	REV
A4	MM [INCH]	Lxh 11/17'14		2 / 5	4:1	1

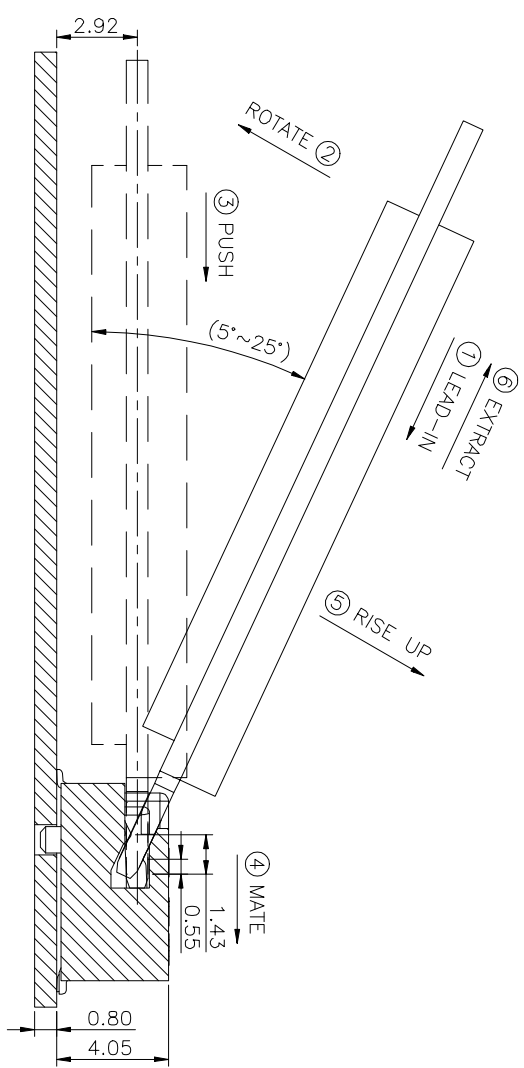
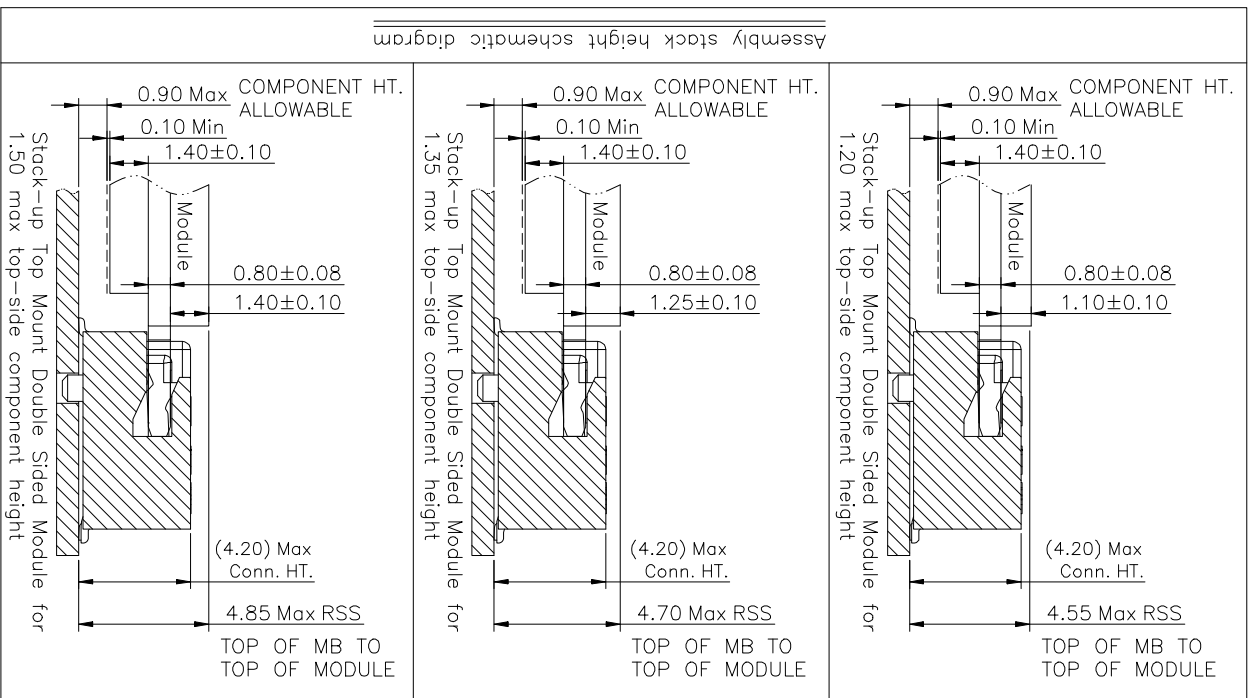

HOW TO MATE AND EXTRACT
MATE: ① → ④
EXTRACT: ⑤ → ⑥

NOTE: Mating force will generate from step 3 to step 4.

GENERAL TOLERANCES UNLESS SPECIFIED		PART NO. SEE TABLE		TITLE	
X ± 0.35	X ± 0.25	APPROVED BY Barney		0.5 PITCH M2 H4.2 (KEY M)	
XX ± 0.15	XXX ± 0.10	CHECKED BY Vito		DWG NO. AP-APC0107	
SIZE A4	UNITS MM	DRAWN BY Lkh	11/17/14	SHEET 3 / 5	SCALE 4:1
			11/17/14	REV 1	



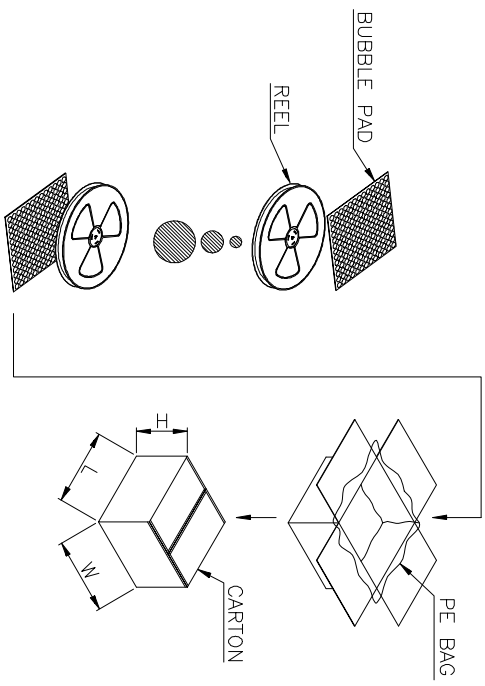
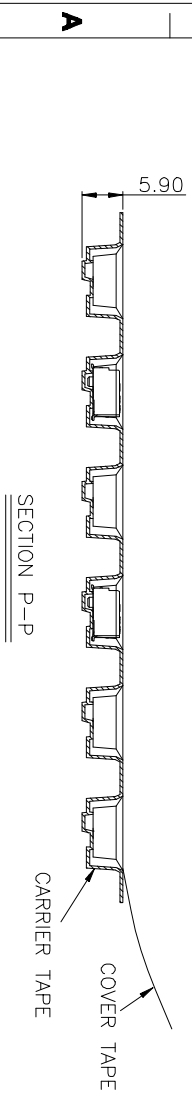
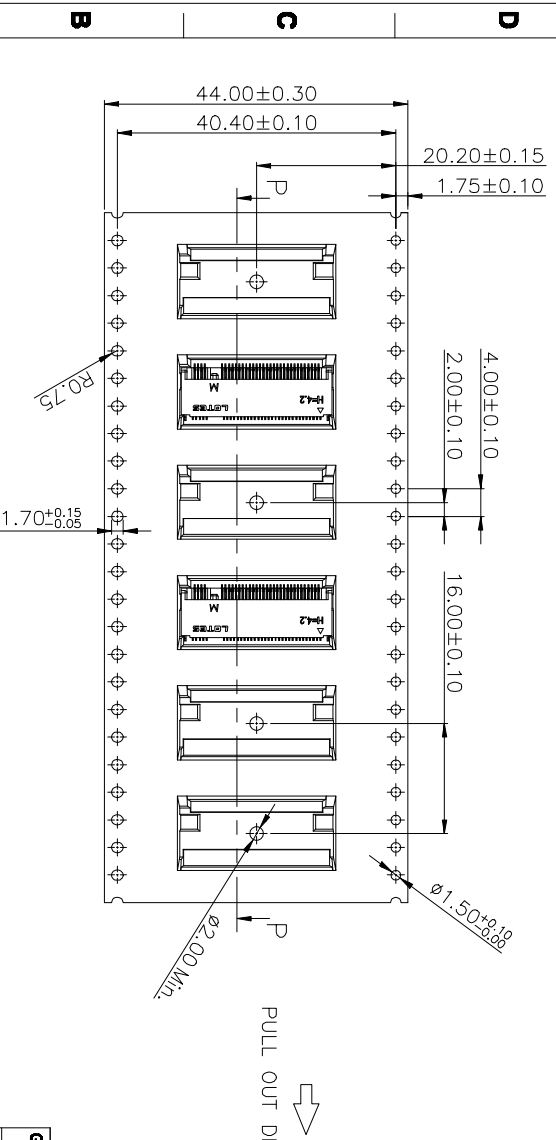
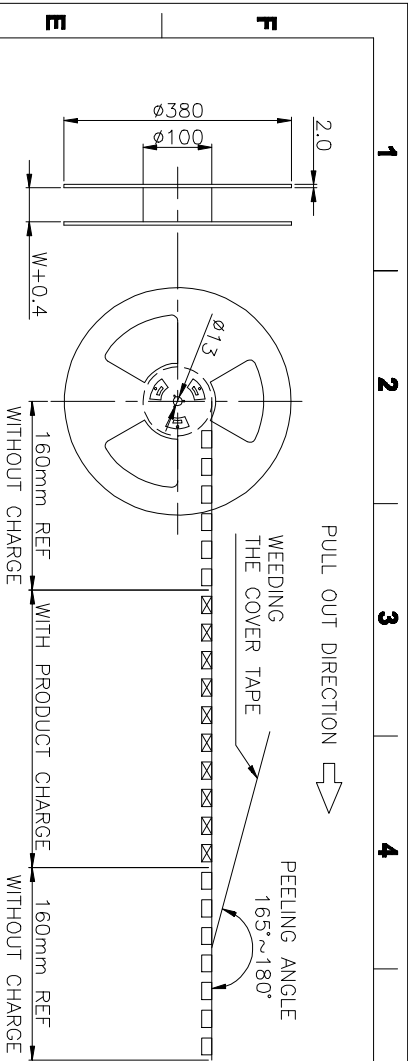

GENERAL TOLERANCES UNLESS SPECIFIED		PART NO. SEE TABLE		TITLE	
X ± 0.35	X ± 2°	APPROVED BY		0.65 PITCH M2 H4.2 (KEY M)	
XX ± 0.25	XX ± 2°	Barney		11/17/14	
XXX ± 0.15	XXX ± 1°	CHECKED BY		DWG NO.	
CUSTOMER DRAWING		V10		AP-APC10107	
SIZE	UNITS	DRAWN BY	Lxh	SHEET	SCALE
A4	MM [INCH]			5 / 5	1:1
		REV		1	

900 5400

PCS/REEL PCS/CARTON

连欣科技
Lian Xin Technology