



AiP74HC/HCT251

8-input Multiplexer; 3-state

Product Specification

Specification Revision History:

Version	Date	Description
2012-06-A1	2012-06	New
2021-12-A2	2021-12	Modify ordering information
2022-01-A3	2022-01	Modify ambient temperature to $-40^{\circ}\text{C}\sim+105^{\circ}\text{C}$ and add electrical characteristics of $-40^{\circ}\text{C}\sim+105^{\circ}\text{C}$



1、 General Description

The AiP74HC/HCT251 is an 8-bit multiplexer with eight binary inputs (I0 to I7), three select inputs (S0 to S2) and an output enable input (\overline{OE}). The select inputs select one of the eight binary inputs and route it to the complementary outputs (Y and \overline{Y}). A HIGH on \overline{OE} causes the outputs to assume a high-impedance OFF-state. Inputs include clamp diodes that enable the use of current limiting resistors to interface inputs to voltages in excess of V_{CC} .

Features:

- Input levels:
 - For AiP74HC251: CMOS level
 - For AiP74HCT251: TTL level
- Low-power dissipation
- Non-inverting data path
- Specified from -40°C to +105°C
- Packaging information: DIP16/SOP16/TSSOP16

**Ordering Information:****Tube packing specifications:**

Part number	Packaging form	Marking code	Tube quantity	Boxed tube quantity	Boxed quantity	Notes
AiP74HC251DA16.TB	DIP16	74HC251	25 PCS/tube	40 tube/box	1000 PCS/box	Dimensions of plastic enclosure: 19.0mm×6.4mm Pin spacing: 2.54mm
AiP74HCT251DA16.TB	DIP16	74HCT251	25 PCS/tube	40 tube/box	1000 PCS/box	Dimensions of plastic enclosure: 19.0mm×6.4mm Pin spacing: 2.54mm
AiP74HC251SA16.TB	SOP16	74HC251	50 PCS/tube	200 tube/box	10000 PCS/box	Dimensions of plastic enclosure: 10.0mm×3.9mm Pin spacing: 1.27mm
AiP74HCT251SA16.TB	SOP16	74HCT251	50 PCS/tube	200 tube/box	10000 PCS/box	Dimensions of plastic enclosure: 10.0mm×3.9mm Pin spacing: 1.27mm
AiP74HC251TA16.TB	TSSOP16	74HC251	96 PCS/tube	200 tube/box	19200 PCS/box	Dimensions of plastic enclosure: 5.0mm×4.4mm Pin spacing: 0.65mm
AiP74HCT251TA16.TB	TSSOP16	74HCT251	96 PCS/tube	200 tube/box	19200 PCS/box	Dimensions of plastic enclosure: 5.0mm×4.4mm Pin spacing: 0.65mm

**Reel packing specifications:**

Part number	Packaging form	Marking code	Reel quantity	Boxed reel quantity	Notes
AiP74HC251SA16.TR	SOP16	74HC251	4000 PCS/reel	8000 PCS/box	Dimensions of plastic enclosure: 10.0mm×3.9mm Pin spacing:1.27mm
AiP74HCT251SA16.TR	SOP16	74HCT251	4000 PCS/reel	8000 PCS/box	Dimensions of plastic enclosure: 10.0mm×3.9mm Pin spacing:1.27mm
AiP74HC251TA16.TR	TSSOP16	74HC251	5000 PCS/reel	10000 PCS/box	Dimensions of plastic enclosure: 5.0mm×4.4mm Pin spacing:0.65mm
AiP74HCT251TA16.TR	TSSOP16	74HCT251	5000 PCS/reel	10000 PCS/box	Dimensions of plastic enclosure: 5.0mm×4.4mm Pin spacing:0.65mm

Note: If the physical information is inconsistent with the ordering information, please refer to the actual product.



2、Block Diagram And Pin Description

2.1、Block Diagram

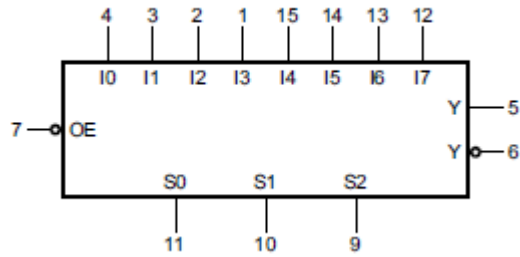

Figure 1. Logic symbol

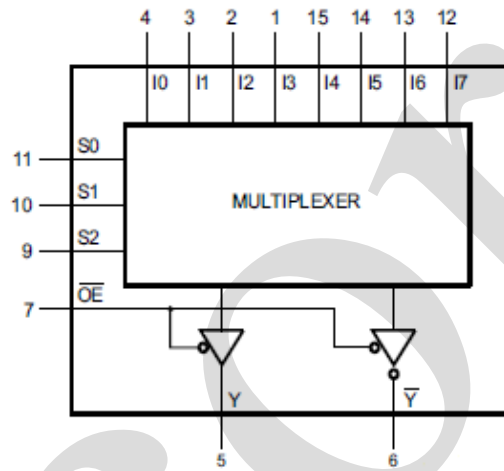

Figure 2. Functional diagram

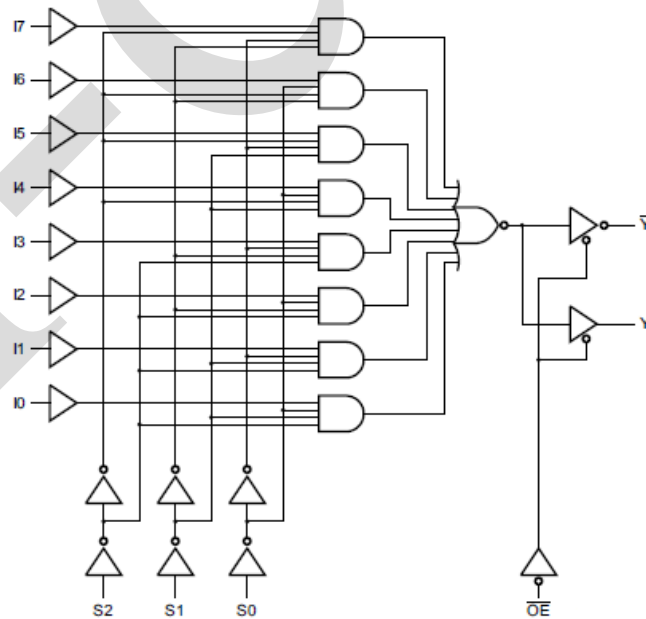
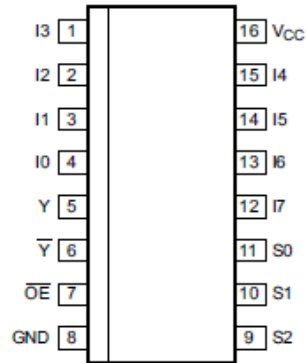

Figure 3. Logic diagram



2.2、Pin Configurations



2.3、Pin Description

Pin No.	Pin Name	Description
1	I3	data input
2	I2	data input
3	I1	data input
4	I0	data input
5	Y	multiplexer output
6	\bar{Y}	complementary multiplexer output
7	\bar{OE}	output enable input (active LOW)
8	GND	ground (0V)
9	S2	common data select input
10	S1	common data select input
11	S0	common data select input
12	I7	data input
13	I6	data input
14	I5	data input
15	I4	data input
16	V _{CC}	supply voltage



2.4、Function Table

Input												Output	
\overline{OE}	S2	S1	S0	I0	I1	I2	I3	I4	I5	I6	I7	Y	\overline{Y}
H	X	X	X	X	X	X	X	X	X	X	X	Z	Z
L	L	L	L	L	X	X	X	X	X	X	X	H	L
L	L	L	L	H	X	X	X	X	X	X	X	L	H
L	L	L	H	X	L	X	X	X	X	X	X	H	L
L	L	L	H	X	H	X	X	X	X	X	X	L	H
L	L	H	L	X	X	L	X	X	X	X	X	H	L
L	L	H	L	X	X	H	X	X	X	X	X	L	H
L	L	H	H	X	X	X	L	X	X	X	X	H	L
L	L	H	H	X	X	X	H	X	X	X	X	L	H
L	H	L	L	X	X	X	X	L	X	X	X	H	L
L	H	L	L	X	X	X	X	H	X	X	X	L	H
L	H	L	H	X	X	X	X	X	L	X	X	H	L
L	H	L	H	X	X	X	X	X	H	X	X	L	H
L	H	H	L	X	X	X	X	X	X	L	X	H	L
L	H	H	L	X	X	X	X	X	X	H	X	L	H
L	H	H	H	X	X	X	X	X	X	X	L	H	L
L	H	H	H	X	X	X	X	X	X	X	H	L	H

Note: H=HIGH voltage level; L=LOW voltage level; X=don't care; Z=high-impedance OFF-state.

3、Electrical Parameter

3.1、Absolute Maximum Ratings

(Voltages are referenced to GND (ground=0V), unless otherwise specified.)

Parameter	Symbol	Conditions	Min.	Max.	Unit
supply voltage	V_{CC}	-	-0.5	+7.0	V
input clamping current	I_{IK}	$V_I < -0.5V$ or $V_I > V_{CC}+0.5V$	-	± 20	mA
output clamping current	I_{OK}	$V_O < -0.5V$ or $V_O > V_{CC}+0.5V$	-	± 20	mA
output current	I_O	$V_O = -0.5V$ to $(V_{CC}+0.5V)$	-	± 25	mA
supply current	I_{CC}	-	-	+50	mA
ground current	I_{GND}	-	-50	-	mA
storage temperature	T_{stg}	-	-65	+150	$^{\circ}C$
total power dissipation	P_{tot}	-	-	500	mW
Soldering temperature	T_L	10s	DIP		$^{\circ}C$
			SOP		

Note:

[1] For DIP16 packages: above $70^{\circ}C$ the value of P_{tot} derates linearly with 12mW/K.

[2] For SOP16 packages: above $70^{\circ}C$ the value of P_{tot} derates linearly with 8mW/K.

[3] For (T)SSOP16 packages: above $60^{\circ}C$ the value of P_{tot} derates linearly with 5.5mW/K.



3.2、Recommended Operating Conditions

Parameter	Symbol	Conditions	Min.	Typ.	Max.	Unit
AiP74H251						
supply voltage	V_{CC}	-	2.0	5.0	6.0	V
input voltage	V_I	-	0	-	V_{CC}	V
output voltage	V_O	-	0	-	V_{CC}	V
input transition rise and fall rate	$\Delta t/\Delta V$	$V_{CC}=2.0V$	-	-	625	ns/V
		$V_{CC}=4.5V$	-	1.67	139	ns/V
		$V_{CC}=6.0V$	-	-	83	ns/V
ambient temperature	T_{amb}	-	-40	-	+105	°C
AiP74HCT251						
supply voltage	V_{CC}	-	4.5	5.0	5.5	V
input voltage	V_I	-	0	-	V_{CC}	V
output voltage	V_O	-	0	-	V_{CC}	V
input transition rise and fall rate	$\Delta t/\Delta V$	$V_{CC}=4.5V$	-	1.67	139	ns/V
ambient temperature	T_{amb}	-	-40	-	+105	°C

3.3、Electrical Characteristics

3.3.1、DC Characteristics 1

($T_{amb}=25^{\circ}C$, voltages are referenced to GND (ground=0V), unless otherwise specified.)

Parameter	Symbol	Conditions	Min.	Typ.	Max.	Unit	
AiP74HC251							
HIGH-level input voltage	V_{IH}	$V_{CC}=2.0V$	1.5	1.2	-	V	
		$V_{CC}=4.5V$	3.15	2.4	-	V	
		$V_{CC}=6.0V$	4.2	3.2	-	V	
LOW-level input voltage	V_{IL}	$V_{CC}=2.0V$	-	0.8	0.5	V	
		$V_{CC}=4.5V$	-	2.1	1.35	V	
		$V_{CC}=6.0V$	-	2.8	1.8	V	
HIGH-level output voltage	V_{OH}	$V_I = V_{IH} \text{ or } V_{IL}$	$I_O=-20\mu A; V_{CC}=2.0V$	1.9	2.0	-	V
			$I_O=-20\mu A; V_{CC}=4.5V$	4.4	4.5	-	V
			$I_O=-20\mu A; V_{CC}=6.0V$	5.9	6.0	-	V
			$I_O=-4.0mA; V_{CC}=4.5V$	3.98	4.32	-	V
			$I_O=-5.2mA; V_{CC}=6.0V$	5.48	5.81	-	V
LOW-level output voltage	V_{OL}	$V_I = V_{IH} \text{ or } V_{IL}$	$I_O=20\mu A; V_{CC}=2.0V$	-	0	0.1	V
			$I_O=20\mu A; V_{CC}=4.5V$	-	0	0.1	V
			$I_O=20\mu A; V_{CC}=6.0V$	-	0	0.1	V
			$I_O=4.0mA; V_{CC}=4.5V$	-	0.15	0.26	V
			$I_O=5.2mA; V_{CC}=6.0V$	-	0.16	0.26	V
input leakage current	I_I	$V_I=V_{CC} \text{ or } GND; V_{CC}=6.0V$	-	-	± 0.1	μA	
OFF-state output current	I_{OZ}	$V_I=V_{IH} \text{ or } V_{IL}; V_O=V_{CC} \text{ or } GND; V_{CC}=6.0V$	-	-	± 0.5	μA	
supply current	I_{CC}	$V_I=V_{CC} \text{ or } GND; I_O=0A; V_{CC}=6.0V$	-	-	8.0	μA	



input capacitance	C_I	-	-	3.5	-	pF	
AiP74HCT251							
HIGH-level input voltage	V_{IH}	$V_{CC}=4.5V$ to $5.5V$	2.0	1.6	-	V	
LOW-level input voltage	V_{IL}	$V_{CC}=4.5V$ to $5.5V$	-	1.2	0.8	V	
HIGH-level output voltage	V_{OH}	$V_I = V_{IH}$ or V_{IL} ; $V_{CC}=4.5V$	$I_O=-20\mu A$	4.4	4.5	-	V
			$I_O=-4.0mA$	3.98	4.32	-	V
LOW-level output voltage	V_{OL}	$V_I = V_{IH}$ or V_{IL} ; $V_{CC}=4.5V$	$I_O=20\mu A$	-	0	0.1	V
			$I_O=4.0mA$	-	0.15	0.26	V
input leakage current	I_I	$V_I=V_{CC}$ or GND; $V_{CC}=5.5V$	-	-	± 0.1	μA	
OFF-state output current	I_{OZ}	$V_I=V_{IH}$ or V_{IL} ; $V_O=V_{CC}$ or GND; $V_{CC}=5.5V$	-	-	± 0.5	μA	
supply current	I_{CC}	$V_I=V_{CC}$ or GND; $I_O=0A$; $V_{CC}=5.5V$	-	-	8.0	μA	
additional supply current	ΔI_{CC}	$V_I=V_{CC}-2.1V$; other inputs at V_{CC} or GND; $I_O=0A$; $V_{CC}=4.5V$ to $5.5V$	per input pin; In inputs	-	100	360	μA
			per input pin; OE input	-	150	540	μA
			per input pin; Sn input	-	150	540	μA
input capacitance	C_I	-	-	3.5	-	pF	

3.3.2、DC Characteristics 2

($T_{amb}=-40^{\circ}C$ to $+85^{\circ}C$, voltages are referenced to GND (ground=0V), unless otherwise specified.)

Parameter	Symbol	Conditions	Min.	Typ.	Max.	Unit	
AiP74HC251							
HIGH-level input voltage	V_{IH}	$V_{CC}=2.0V$	1.5	-	-	V	
		$V_{CC}=4.5V$	3.15	-	-	V	
		$V_{CC}=6.0V$	4.2	-	-	V	
LOW-level input voltage	V_{IL}	$V_{CC}=2.0V$	-	-	0.5	V	
		$V_{CC}=4.5V$	-	-	1.35	V	
		$V_{CC}=6.0V$	-	-	1.8	V	
HIGH-level output voltage	V_{OH}	$V_I = V_{IH}$ or V_{IL}	$I_O=-20\mu A$; $V_{CC}=2.0V$	1.9	-	-	V
			$I_O=-20\mu A$; $V_{CC}=4.5V$	4.4	-	-	V
			$I_O=-20\mu A$; $V_{CC}=6.0V$	5.9	-	-	V
			$I_O=-4.0mA$; $V_{CC}=4.5V$	3.84	-	-	V
			$I_O=-5.2mA$; $V_{CC}=6.0V$	5.34	-	-	V
LOW-level output voltage	V_{OL}	$V_I = V_{IH}$ or V_{IL}	$I_O=20\mu A$; $V_{CC}=2.0V$	-	-	0.1	V
			$I_O=20\mu A$; $V_{CC}=4.5V$	-	-	0.1	V
			$I_O=20\mu A$; $V_{CC}=6.0V$	-	-	0.1	V
			$I_O=4.0mA$; $V_{CC}=4.5V$	-	-	0.33	V
			$I_O=5.2mA$; $V_{CC}=6.0V$	-	-	0.33	V
input leakage current	I_I	$V_I=V_{CC}$ or GND; $V_{CC}=6.0V$	-	-	± 1.0	μA	
OFF-state	I_{OZ}	$V_I=V_{IH}$ or V_{IL} ; $V_O=V_{CC}$ or GND; $V_{CC}=6.0V$	-	-	± 5.0	μA	



output current							
supply current	I_{CC}	$V_I=V_{CC}$ or GND; $I_O=0A$; $V_{CC}=6.0V$	-	-	80	uA	
AiP74HC251							
HIGH-level input voltage	V_{IH}	$V_{CC}=4.5V$ to 5.5V	2.0	-	-	V	
LOW-level input voltage	V_{IL}	$V_{CC}=4.5V$ to 5.5V	-	-	0.8	V	
HIGH-level output voltage	V_{OH}	$V_I = V_{IH}$ or V_{IL} ; $V_{CC}=4.5V$	$I_O=-20uA$	4.4	-	-	V
			$I_O=-4.0mA$	3.84	-	-	V
LOW-level output voltage	V_{OL}	$V_I = V_{IH}$ or V_{IL} ; $V_{CC}=4.5V$	$I_O=20uA$	-	-	0.1	V
			$I_O=4.0mA$	-	-	0.33	V
input leakage current	I_I	$V_I=V_{CC}$ or GND; $V_{CC}=5.5V$	-	-	± 1.0	uA	
OFF-state output current	I_{OZ}	$V_I=V_{IH}$ or V_{IL} ; $V_O=V_{CC}$ or GND; $V_{CC}=5.5V$	-	-	± 5.0	uA	
supply current	I_{CC}	$V_I=V_{CC}$ or GND; $I_O=0A$; $V_{CC}=5.5V$	-	-	80	uA	
additional supply current	ΔI_{CC}	$V_I=V_{CC}-2.1V$; other inputs at V_{CC} or GND; $I_O=0A$; $V_{CC}=4.5V$ to 5.5V	per input pin; In inputs	-	-	450	uA
			per input pin; OE input	-	-	675	uA
			per input pin; Sn input	-	-	675	uA

3.3.3、DC Characteristics 3

($T_{amb}=-40^{\circ}C$ to $+105^{\circ}C$, voltages are referenced to GND (ground=0V), unless otherwise specified.)

Parameter	Symbol	Conditions	Min.	Typ.	Max.	Unit	
AiP74HC251							
HIGH-level input voltage	V_{IH}	$V_{CC}=2.0V$	1.5	-	-	V	
		$V_{CC}=4.5V$	3.15	-	-	V	
		$V_{CC}=6.0V$	4.2	-	-	V	
LOW-level input voltage	V_{IL}	$V_{CC}=2.0V$	-	-	0.5	V	
		$V_{CC}=4.5V$	-	-	1.35	V	
		$V_{CC}=6.0V$	-	-	1.8	V	
HIGH-level output voltage	V_{OH}	$V_I = V_{IH}$ or V_{IL}	$I_O=-20uA$; $V_{CC}=2.0V$	1.9	-	-	V
			$I_O=-20uA$; $V_{CC}=4.5V$	4.4	-	-	V
			$I_O=-20uA$; $V_{CC}=6.0V$	5.9	-	-	V
			$I_O=-4.0mA$; $V_{CC}=4.5V$	3.7	-	-	V
			$I_O=-5.2mA$; $V_{CC}=6.0V$	5.2	-	-	V
LOW-level output voltage	V_{OL}	$V_I = V_{IH}$ or V_{IL}	$I_O=20uA$; $V_{CC}=2.0V$	-	-	0.1	V
			$I_O=20uA$; $V_{CC}=4.5V$	-	-	0.1	V
			$I_O=20uA$; $V_{CC}=6.0V$	-	-	0.1	V
			$I_O=4.0mA$; $V_{CC}=4.5V$	-	-	0.4	V
			$I_O=5.2mA$; $V_{CC}=6.0V$	-	-	0.4	V
input leakage current	I_I	$V_I=V_{CC}$ or GND; $V_{CC}=6.0V$	-	-	± 1.0	uA	
OFF-state output current	I_{OZ}	$V_I=V_{IH}$ or V_{IL} ; $V_O=V_{CC}$ or GND; $V_{CC}=6.0V$	-	-	± 10	uA	



supply current	I_{CC}	$V_I=V_{CC}$ or GND; $I_O=0A$; $V_{CC}=6.0V$	-	-	160	uA	
AiP74HC251							
HIGH-level input voltage	V_{IH}	$V_{CC}=4.5V$ to $5.5V$	2.0	-	-	V	
LOW-level input voltage	V_{IL}	$V_{CC}=4.5V$ to $5.5V$	-	-	0.8	V	
HIGH-level output voltage	V_{OH}	$V_I = V_{IH}$ or V_{IL} ; $V_{CC}=4.5V$	$I_O=-20uA$	4.4	-	-	V
			$I_O=-4.0mA$	3.7	-	-	V
LOW-level output voltage	V_{OL}	$V_I = V_{IH}$ or V_{IL} ; $V_{CC}=4.5V$	$I_O=20uA$	-	-	0.1	V
			$I_O=4.0mA$	-	-	0.4	V
input leakage current	I_I	$V_I=V_{CC}$ or GND; $V_{CC}=5.5V$	-	-	± 1.0	uA	
OFF-state output current	I_{OZ}	$V_I=V_{IH}$ or V_{IL} ; $V_O=V_{CC}$ or GND; $V_{CC}=5.5V$	-	-	± 10	uA	
supply current	I_{CC}	$V_I=V_{CC}$ or GND; $I_O=0A$; $V_{CC}=5.5V$	-	-	160	uA	
additional supply current	ΔI_{CC}	$V_I=V_{CC}-2.1V$; other inputs at V_{CC} or GND; $I_O=0A$; $V_{CC}=4.5V$ to $5.5V$	per input pin; In inputs	-	-	490	uA
			per input pin; OE input	-	-	735	uA
			per input pin; Sn input	-	-	735	uA

3.3.4、AC Characteristics 1

($T_{amb}=25^{\circ}C$, GND =0V, $C_L=50pF$, unless otherwise specified.)

Parameter	Symbol	Conditions	Min.	Typ.	Max.	Unit	
AiP74HC251							
propagation delay	t_{pd}	In to Y; see Figure 5	$V_{CC}=2.0V$	-	50	170	ns
			$V_{CC}=4.5V$	-	18	34	ns
			$V_{CC}=5.0V$; $C_L=15pF$	-	15	-	ns
			$V_{CC}=6.0V$	-	14	29	ns
		In to \bar{Y} ; see Figure 5	$V_{CC}=2.0V$	-	55	175	ns
			$V_{CC}=4.5V$	-	20	35	ns
			$V_{CC}=5.0V$; $C_L=15pF$	-	17	-	ns
			$V_{CC}=6.0V$	-	16	30	ns
		Sn to Y; see Figure 6	$V_{CC}=2.0V$	-	66	205	ns
			$V_{CC}=4.5V$	-	24	41	ns
			$V_{CC}=5.0V$; $C_L=15pF$	-	20	-	ns
			$V_{CC}=6.0V$	-	19	35	ns
		Sn to \bar{Y} ; see Figure 6	$V_{CC}=2.0V$	-	69	205	ns
			$V_{CC}=4.5V$	-	25	41	ns
			$V_{CC}=5.0V$; $C_L=15pF$	-	21	-	ns
			$V_{CC}=6.0V$	-	20	35	ns
\bar{OE} to Y, \bar{Y} enable time	t_{en}	see Figure 6	$V_{CC}=2.0V$	-	36	140	ns
			$V_{CC}=4.5V$	-	13	28	ns
			$V_{CC}=6.0V$	-	10	24	ns
\bar{OE} to Y, \bar{Y} disable time	t_{dis}	see Figure 6	$V_{CC}=2.0V$	-	39	140	ns
			$V_{CC}=4.5V$	-	14	28	ns



			$V_{CC}=6.0V$	-	11	24	ns
transition time	t_t	Y, \bar{Y} ; see Figure 5	$V_{CC}=2.0V$	-	19	75	ns
			$V_{CC}=4.5V$	-	7	15	ns
			$V_{CC}=6.0V$	-	6	13	ns
power dissipation capacitance	C_{PD}	$C_L=50pF; f=1MHz; V_I=GND \text{ to } V_{CC}$		-	44	-	pF
AiP74HCT251							
propagation delay	t_{pd}	In to Y; see Figure 5	$V_{CC}=4.5V$	-	22	35	ns
			$V_{CC}=5.0V; C_L=15pF$	-	19	-	ns
		In to \bar{Y} ; see Figure 5	$V_{CC}=4.5V$	-	22	35	ns
			$V_{CC}=5.0V; C_L=15pF$	-	19	-	ns
		Sn to Y; see Figure 6	$V_{CC}=4.5V$	-	24	44	ns
			$V_{CC}=5.0V; C_L=15pF$	-	20	-	ns
Sn to \bar{Y} ; see Figure 6	$V_{CC}=4.5V$	-	25	44	ns		
	$V_{CC}=5.0V; C_L=15pF$	-	21	-	ns		
\bar{OE} to Y, \bar{Y} enable time	t_{en}	see Figure 6	$V_{CC}=4.5V$	-	13	28	ns
			$V_{CC}=5.0V; C_L=15pF$	-	13	-	ns
\bar{OE} to Y, \bar{Y} disable time	t_{dis}	see Figure 6	$V_{CC}=4.5V$	-	14	28	ns
			$V_{CC}=5.0V; C_L=15pF$	-	18	-	ns
transition time	t_t	Y, $\bar{Y}; V_{CC}=4.5V$; see Figure 5		-	7	15	ns
power dissipation capacitance	C_{PD}	$C_L=50pF; f=1MHz; V_I=GND \text{ to } V_{CC}-1.5V$		-	46	-	pF

Note:

[1] t_{pd} is the same as t_{PLH} and t_{PHL} .

[2] t_{en} is the same as t_{PZH} and t_{PZL} .

[3] t_{dis} is the same as t_{PLZ} and t_{PHZ} .

[4] t_t is the same as t_{THL} and t_{TLH} .

[5] C_{PD} is used to determine the dynamic power dissipation (P_D in uW).

$$P_D = C_{PD} \times V_{CC}^2 \times f_i \times N + \sum (C_L \times V_{CC}^2 \times f_o) \text{ where:}$$

f_i =input frequency in MHz;

f_o =output frequency in MHz;

C_L =output load capacitance in pF;

V_{CC} =supply voltage in V;

N =number of inputs switching;

$\sum (C_L \times V_{CC}^2 \times f_o)$ =sum of outputs.



3.3.5、AC Characteristics 2

($T_{amb} = -40^{\circ}\text{C}$ to $+85^{\circ}\text{C}$, $GND=0\text{V}$, $C_L=50\text{pF}$, unless otherwise specified.)

Parameter	Symbol	Conditions	Min.	Typ.	Max.	Unit	
AiP74HC251							
propagation delay	t_{pd}	In to Y; see Figure 5	$V_{CC}=2.0\text{V}$	-	-	215	ns
			$V_{CC}=4.5\text{V}$	-	-	43	ns
			$V_{CC}=6.0\text{V}$	-	-	37	ns
		In to \bar{Y} ; see Figure 5	$V_{CC}=2.0\text{V}$	-	-	220	ns
			$V_{CC}=4.5\text{V}$	-	-	44	ns
			$V_{CC}=6.0\text{V}$	-	-	37	ns
		Sn to Y; see Figure 6	$V_{CC}=2.0\text{V}$	-	-	255	ns
			$V_{CC}=4.5\text{V}$	-	-	51	ns
			$V_{CC}=6.0\text{V}$	-	-	43	ns
		Sn to \bar{Y} ; see Figure 6	$V_{CC}=2.0\text{V}$	-	-	255	ns
			$V_{CC}=4.5\text{V}$	-	-	51	ns
			$V_{CC}=6.0\text{V}$	-	-	43	ns
\bar{OE} to Y, \bar{Y} enable time	t_{en}	see Figure 6	$V_{CC}=2.0\text{V}$	-	-	175	ns
			$V_{CC}=4.5\text{V}$	-	-	35	ns
			$V_{CC}=6.0\text{V}$	-	-	30	ns
\bar{OE} to Y, \bar{Y} disable time	t_{dis}	see Figure 6	$V_{CC}=2.0\text{V}$	-	-	170	ns
			$V_{CC}=4.5\text{V}$	-	-	35	ns
			$V_{CC}=6.0\text{V}$	-	-	30	ns
transition time	t_t	Y, \bar{Y} ; see Figure 5	$V_{CC}=2.0\text{V}$	-	-	95	ns
			$V_{CC}=4.5\text{V}$	-	-	19	ns
			$V_{CC}=6.0\text{V}$	-	-	16	ns
AiP74HCT251							
propagation delay	t_{pd}	In to Y; see Figure 5	$V_{CC}=4.5\text{V}$	-	-	44	ns
		In to \bar{Y} ; see Figure 5	$V_{CC}=4.5\text{V}$	-	-	44	ns
		Sn to Y; see Figure 6	$V_{CC}=4.5\text{V}$	-	-	55	ns
		Sn to \bar{Y} ; see Figure 6	$V_{CC}=4.5\text{V}$	-	-	55	ns
\bar{OE} to Y, \bar{Y} enable time	t_{en}	see Figure 6	$V_{CC}=4.5\text{V}$	-	-	35	ns
\bar{OE} to Y, \bar{Y} disable time	t_{dis}	see Figure 6	$V_{CC}=4.5\text{V}$	-	-	35	ns
transition time	t_t	Y, \bar{Y} ; $V_{CC}=4.5\text{V}$; see Figure 5	-	-	19	ns	

Note:

[1] t_{pd} is the same as t_{PLH} and t_{PHL} .

[2] t_{en} is the same as t_{PZH} and t_{PZL} .

[3] t_{dis} is the same as t_{PLZ} and t_{PHZ} .

[4] t_t is the same as t_{THL} and t_{TLH} .



3.3.6、AC Characteristics 3

($T_{amb} = -40^{\circ}\text{C}$ to $+105^{\circ}\text{C}$, $GND = 0\text{V}$, $C_L = 50\text{pF}$, unless otherwise specified.)

Parameter	Symbol	Conditions	Min.	Typ.	Max.	Unit	
AiP74HC251							
propagation delay	t_{pd}	In to Y; see Figure 5	$V_{CC} = 2.0\text{V}$	-	-	255	ns
			$V_{CC} = 4.5\text{V}$	-	-	51	ns
			$V_{CC} = 6.0\text{V}$	-	-	43	ns
		In to \bar{Y} ; see Figure 5	$V_{CC} = 2.0\text{V}$	-	-	265	ns
			$V_{CC} = 4.5\text{V}$	-	-	53	ns
			$V_{CC} = 6.0\text{V}$	-	-	45	ns
		Sn to Y; see Figure 6	$V_{CC} = 2.0\text{V}$	-	-	310	ns
			$V_{CC} = 4.5\text{V}$	-	-	62	ns
			$V_{CC} = 6.0\text{V}$	-	-	53	ns
		Sn to \bar{Y} ; see Figure 6	$V_{CC} = 2.0\text{V}$	-	-	310	ns
			$V_{CC} = 4.5\text{V}$	-	-	62	ns
			$V_{CC} = 6.0\text{V}$	-	-	53	ns
\bar{OE} to Y, \bar{Y} enable time	t_{en}	see Figure 6	$V_{CC} = 2.0\text{V}$	-	-	210	ns
			$V_{CC} = 4.5\text{V}$	-	-	42	ns
			$V_{CC} = 6.0\text{V}$	-	-	36	ns
\bar{OE} to Y, \bar{Y} disable time	t_{dis}	see Figure 6	$V_{CC} = 2.0\text{V}$	-	-	210	ns
			$V_{CC} = 4.5\text{V}$	-	-	42	ns
			$V_{CC} = 6.0\text{V}$	-	-	36	ns
transition time	t_t	Y, \bar{Y} ; see Figure 5	$V_{CC} = 2.0\text{V}$	-	-	110	ns
			$V_{CC} = 4.5\text{V}$	-	-	22	ns
			$V_{CC} = 6.0\text{V}$	-	-	19	ns
AiP74HCT251							
propagation delay	t_{pd}	In to Y; see Figure 5	$V_{CC} = 4.5\text{V}$	-	-	53	ns
		In to \bar{Y} ; see Figure 5	$V_{CC} = 4.5\text{V}$	-	-	53	ns
		Sn to Y; see Figure 6	$V_{CC} = 4.5\text{V}$	-	-	66	ns
		Sn to \bar{Y} ; see Figure 6	$V_{CC} = 4.5\text{V}$	-	-	66	ns
\bar{OE} to Y, \bar{Y} enable time	t_{en}	see Figure 6	$V_{CC} = 4.5\text{V}$	-	-	42	ns
\bar{OE} to Y, \bar{Y} disable time	t_{dis}	see Figure 6	$V_{CC} = 4.5\text{V}$	-	-	42	ns
transition time	t_t	Y, \bar{Y} ; $V_{CC} = 4.5\text{V}$; see Figure 5	-	-	22	ns	

Note:

- [1] t_{pd} is the same as t_{PLH} and t_{PHL} .
- [2] t_{en} is the same as t_{PZH} and t_{PZL} .
- [3] t_{dis} is the same as t_{PLZ} and t_{PHZ} .
- [4] t_t is the same as t_{THL} and t_{TLH} .



4、 Testing Circuit

4.1、 AC Testing Circuit

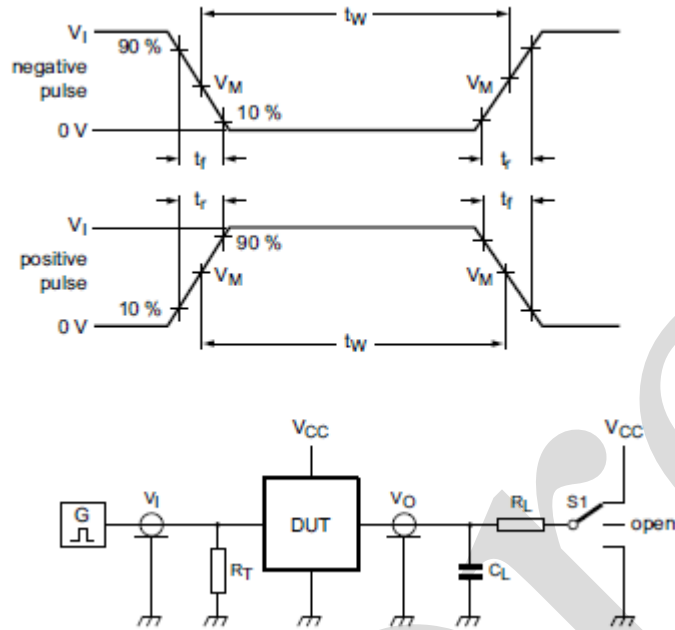

Figure 4. Test circuit for measuring switching times

Definitions for test circuit:

C_L =Load capacitance including jig and probe capacitance.

R_T =Termination resistance should be equal to the output impedance Z_o of the pulse generator.

R_L =Load resistance.

S1=Test selection switch.

4.2、 AC Testing Waveforms

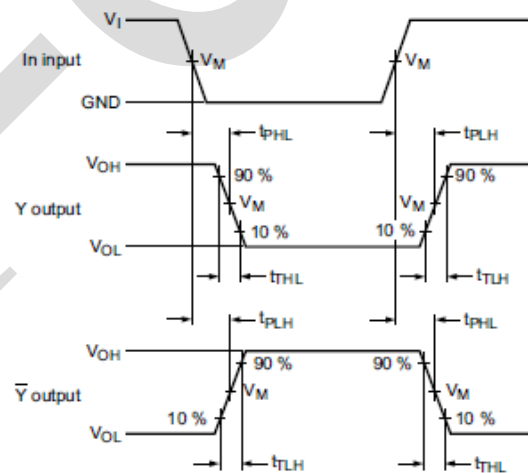

Figure 5. Propagation delay input (In) to output (Y, \bar{Y}) and the output (Y, \bar{Y}) transition time

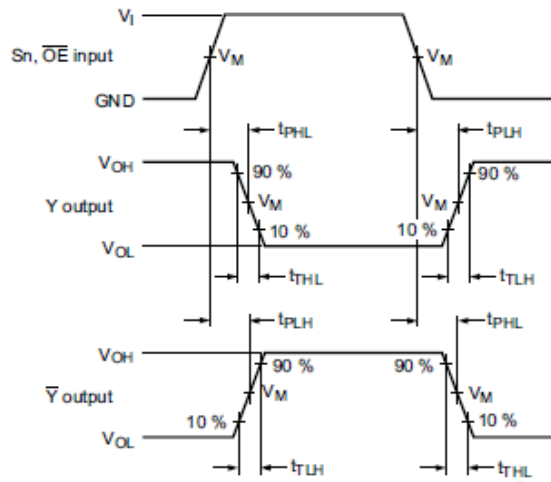

Figure 6. Propagation delay input (Sn, OE) to output (Y, Y-bar)

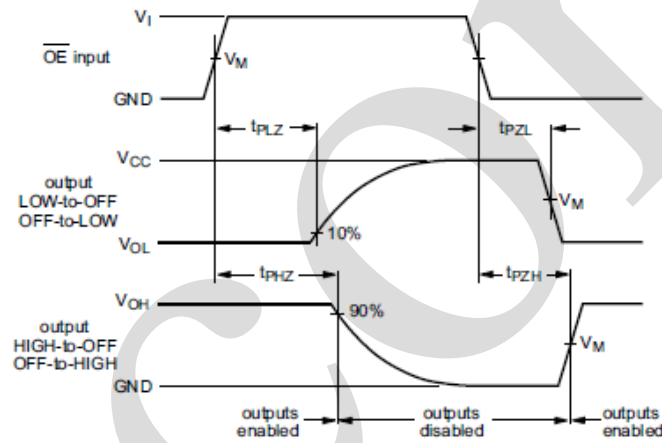

Figure 7. Enable and disable times

4.3、 Measurement Points

Type	Input	Output
	V _M	V _M
AiP74HC251	0.5×V _{CC}	0.5×V _{CC}
AiP74HCT251	1.3V	1.3V

4.4、 Test Data

Type	Input		Load		S1 position		
	V _I	t _r , t _f	C _L	R _L	t _{PHL} , t _{PLH}	t _{PZH} , t _{PHZ}	t _{PZL} , t _{PLZ}
AiP74HC251	V _{CC}	6ns	15pF, 50pF	1kΩ	open	GND	V _{CC}
AiP74HCT251	3V	6ns	15pF, 50pF	1kΩ	open	GND	V _{CC}



5、Package Information

5.1、DIP16

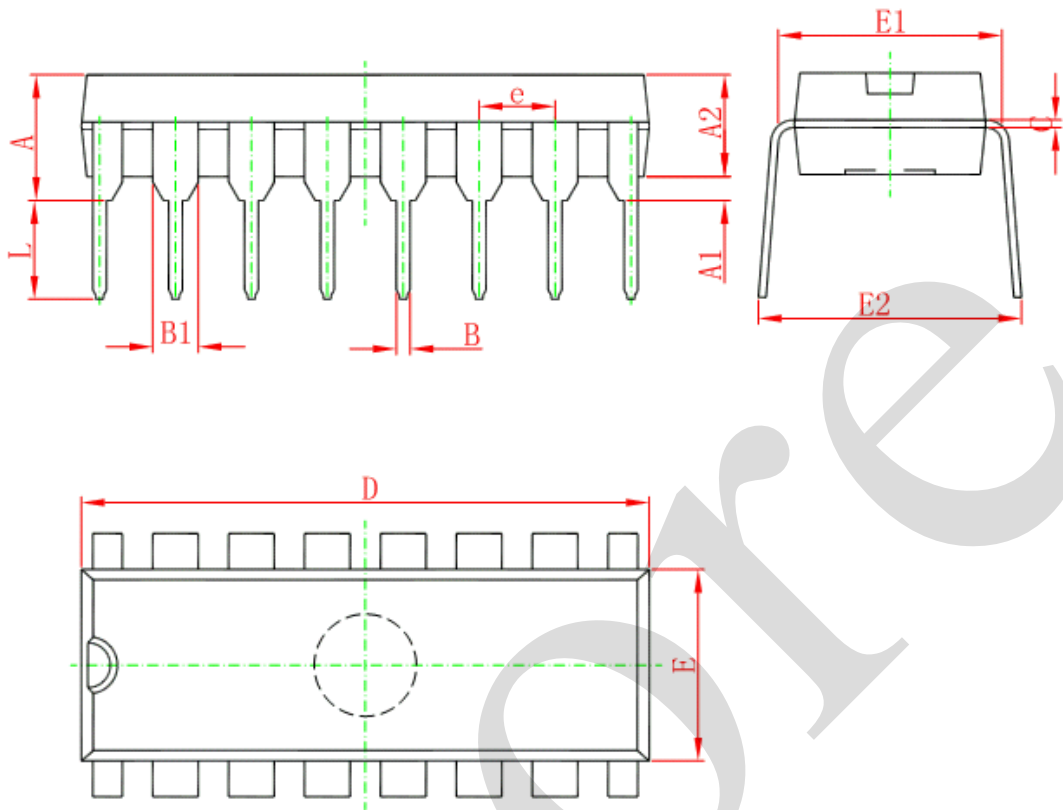

Symbol	Dimensions In Millimeters		Dimensions In Inches	
	Min	Max	Min	Max
A	3.710	4.310	0.146	0.170
A1	0.510		0.020	
A2	3.200	3.600	0.126	0.142
B	0.380	0.570	0.015	0.022
B1	1.524 (BSC)		0.060 (BSC)	
C	0.204	0.360	0.008	0.014
D	18.800	19.200	0.740	0.756
E	6.200	6.600	0.244	0.260
E1	7.320	7.920	0.288	0.312
e	2.540 (BSC)		0.100 (BSC)	
L	3.000	3.600	0.118	0.142
E2	8.400	9.000	0.331	0.354



5.2、SOP16

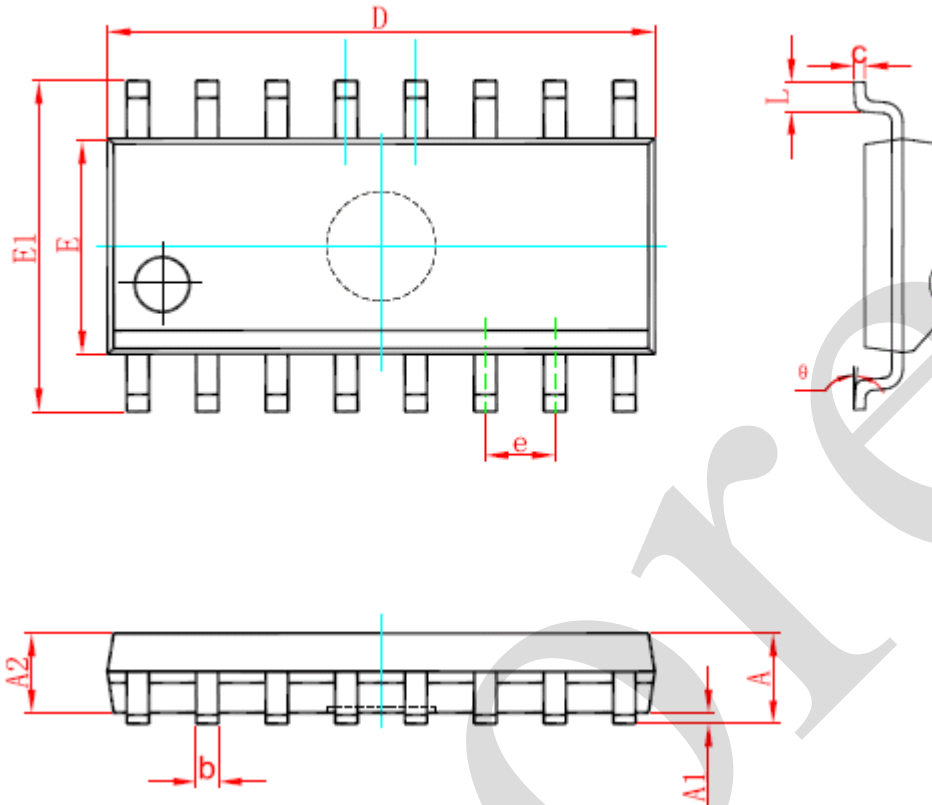

Symbol	Dimensions In Millimeters		Dimensions In Inches	
	Min	Max	Min	Max
A	1.350	1.750	0.053	0.069
A1	0.100	0.250	0.004	0.010
A2	1.350	1.550	0.053	0.061
b	0.330	0.510	0.013	0.020
c	0.170	0.250	0.007	0.010
D	9.800	10.200	0.386	0.402
E	3.800	4.000	0.150	0.157
E1	5.800	6.200	0.228	0.244
e	1.270 (BSC)		0.050 (BSC)	
L	0.400	1.270	0.016	0.050
θ	0°	8°	0°	8°



5.3、TSSOP16

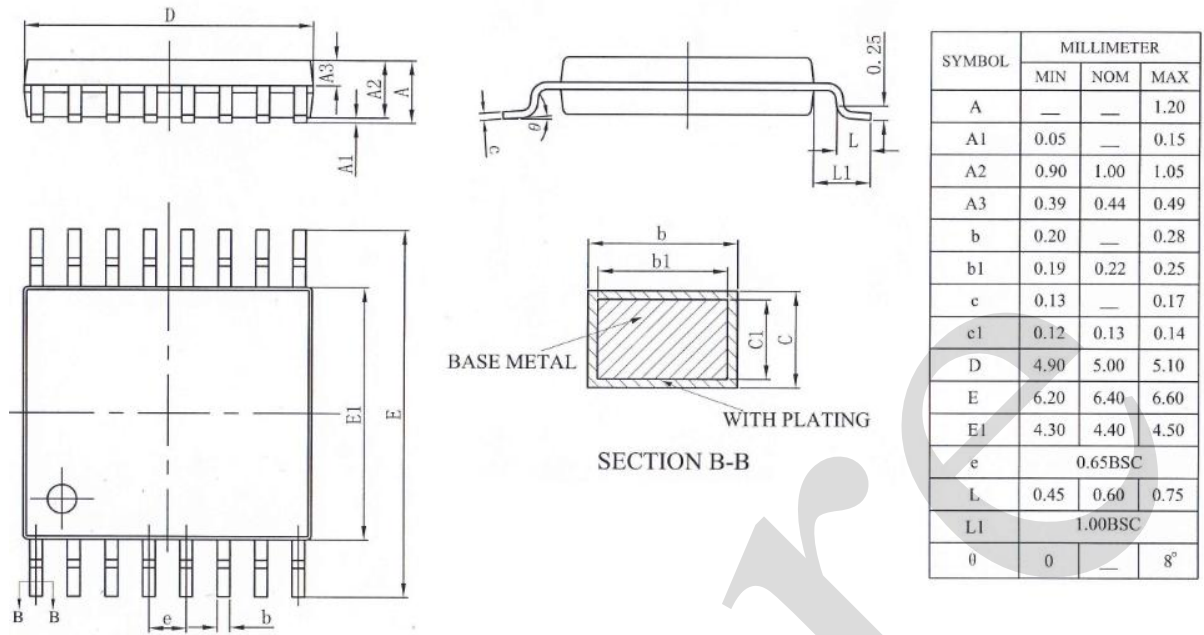



6、 Statements And Notes

6.1、 The name and content of Hazardous substances or Elements in the product

Part name	Hazardous substances or Elements									
	Lead and lead compounds	Mercury and mercury compounds	Cadmium and cadmium compounds	Hexavalent chromium compounds	Polybrominated biphenyls	Polybrominated biphenyl ethers	Dibutyl phthalate	Butylbenzyl phthalate	Di-2-ethylhexyl phthalate	Diisobutyl phthalate
Lead frame	○	○	○	○	○	○	○	○	○	○
Plastic resin	○	○	○	○	○	○	○	○	○	○
Chip	○	○	○	○	○	○	○	○	○	○
The lead	○	○	○	○	○	○	○	○	○	○
Plastic sheet installed	○	○	○	○	○	○	○	○	○	○
explanation	○: Indicates that the content of hazardous substances or elements in the detection limit of the following the SJ/T11363-2006 standard. ×: Indicates that the content of hazardous substances or elements exceeding the SJ/T11363-2006 Standard limit requirements.									

6.2、 Notion

Recommended carefully reading this information before the use of this product;

The information in this document are subject to change without notice;

This information is using to the reference only, the company is not responsible for any loss;

The company is not responsible for the any infringement of the third party patents or other rights of the responsibility.