

## Technical Data Sheet

### Side View White LED (0.6mm)

**99-216/B7C-AS1T2N/2C**

#### Features

- Side view LED.
- Lead frame package with individual 2 pins.
- Wide viewing angle.
- Soldering methods: IR reflow soldering.
- Pb-free.
- The product itself will remain within RoHS compliant version.



#### Descriptions

- The 99-216 series is available in soft orange, green, blue and yellow. Due to the package design, the LED has wide viewing angle and optimized light coupling by inter reflector. This feature makes the LED ideal for light guide application.

#### Applications

- LCD Back Light.
- Mobile phones .
- Indicators.
- Illuminations.
- Switch Lights.

#### Device Selection Guide

Chip		Resin Color
Material	Emitted Color	
InGaN	Blue	Water Clear

**Technical Data Sheet**

**Side View White LED (0.6mm)**

**99-216/B7C-AS1T2N/2C**

**Package Outline Dimensions**

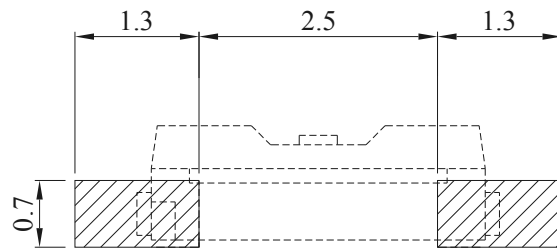
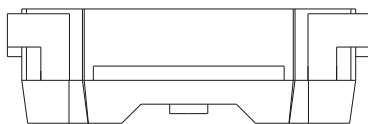
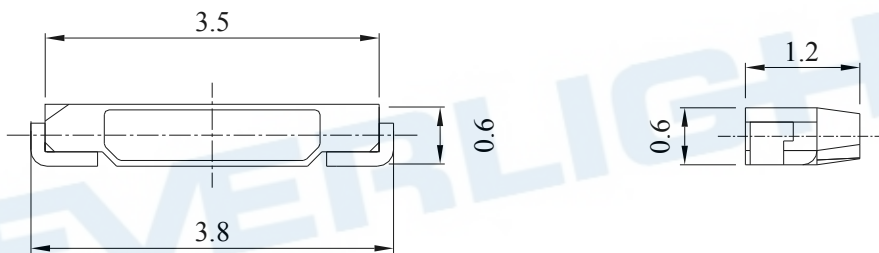
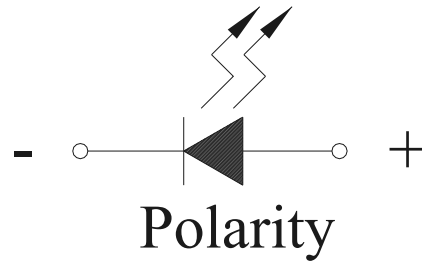
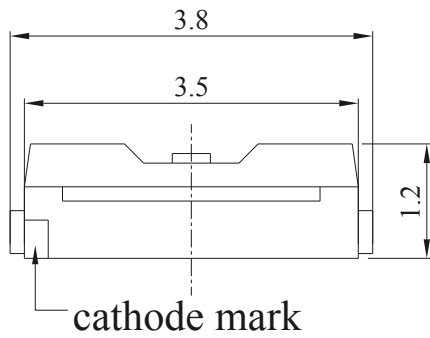

Recommended soldering pad design

**Note:** The tolerance unless mentioned is  $\pm 0.1\text{mm}$ , Unit = mm.

**Technical Data Sheet****Side View White LED (0.6mm)****99-216/B7C-AS1T2N/2C****Absolute Maximum Ratings (Ta=25°C)**

Parameter	Symbol	Rating	Unit
Reverse Voltage	$V_R$	5	V
Forward Current	$I_F$	30	mA
Peak Forward Current (Duty 1/10 @10ms)	$I_{FP}$	100	mA
Power Dissipation	$P_d$	110	mW
Electrostatic Discharge(HBM)* <sup>1</sup>	ESD	1000	V
Operating Temperature	$T_{opr}$	-40 ~ +85	°C
Storage Temperature	$T_{stg}$	-40 ~ +90	°C
Soldering Temperature	$T_{sol}$	Reflow Soldering : 260 °C for 10 sec. Hand Soldering : 350 °C for 3 sec.	

**Electro-Optical Characteristics (Ta=25°C)**

Parameter	Symbol	Min.	Typ.	Max.	Unit	Condition
Luminous Intensity	$I_V$	180	---	450	mcd	$I_F=20mA$
Viewing Angle	2θ1/2	-----	110	-----	deg	$I_F=20mA$
Peak Wavelength	$\lambda_p$	-----	468	-----	nm	$I_F=20mA$
Dominant Wavelength	$\lambda_d$	464.5	-----	476.5	nm	$I_F=20mA$
Spectrum Radiation Bandwidth	$\Delta \lambda$	-----	35	-----	nm	$I_F=20mA$
Forward Voltage	$V_F$	2.70	-----	3.70	V	$I_F=20mA$
Reverse Current	$I_R$	-----	-----	50	μA	$V_R=5V$

**Notes:**

- 1.Tolerance of Luminous Intensity : ±11%
- 2.Tolerance of Dominant Wavelength : ±1nm
- 3.Tolerance of Forward Voltage : ±0.1V

**Technical Data Sheet****Side View White LED (0.6mm)****99-216/B7C-AS1T2N/2C****Bin Range of Luminous Intensity**

Bin	Min	Max	Unit	Condition
S1	180	225	mcd	I <sub>F</sub> =20mA
S2	225	285		
T1	285	360		
T2	360	450		

**Bin Range of Dominant Wavelength**

Group	Bin Code	Min.	Max.	Unit	Condition
A	A9	464.5	467.5	nm	I <sub>F</sub> =20mA
	A10	467.5	470.5		
	A11	470.5	473.5		
	A12	473.5	476.5		

**Bin Range of Forward Voltage**

Group	Bin Code	Min.	Max.	Unit	Condition
N	10	2.70	2.90	V	I <sub>F</sub> =20mA
	11	2.90	3.10		
	12	3.10	3.30		
	13	3.30	3.50		
	14	3.50	3.70		

**Notes:**

- 1.Tolerance of Luminous Intensity :  $\pm 11\%$
- 2.Tolerance of Dominant Wavelength :  $\pm 1\text{nm}$
- 3.Tolerance of Forward Voltage :  $\pm 0.1\text{V}$

**Technical Data Sheet**

**Side View White LED (0.6mm)**

**99-216/B7C-AS1T2N/2C**

**Typical Electro-Optical Characteristics Curves**

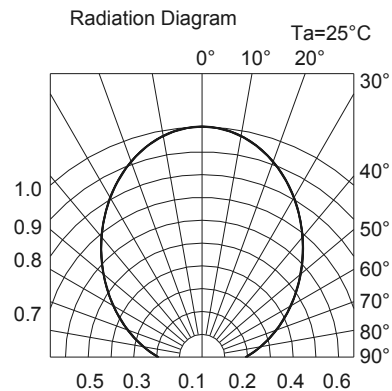
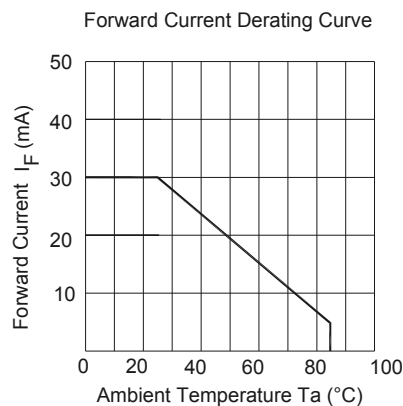
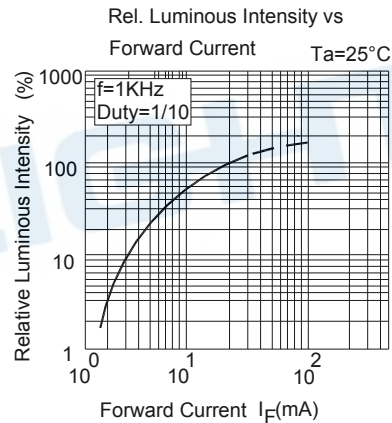
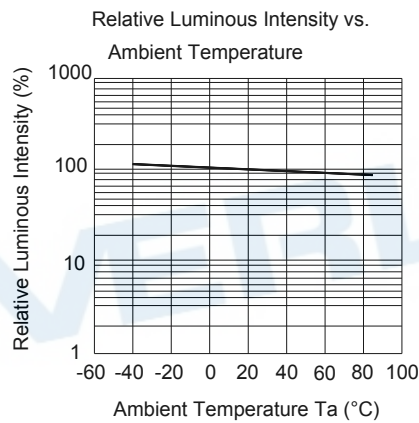
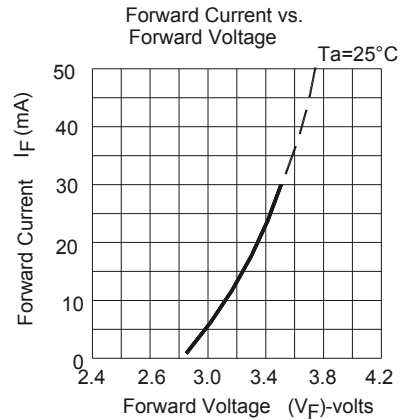
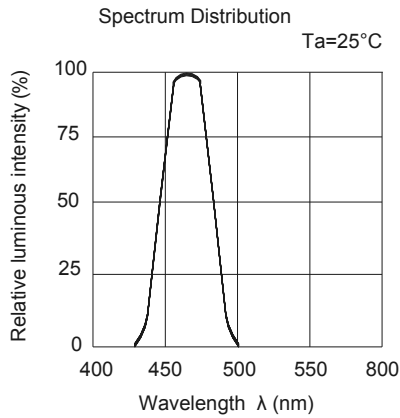

**Technical Data Sheet**

**Side View White LED (0.6mm)**

**99-216/B7C-AS1T2N/2C**

**Label Explanation**

CAT: Luminous Intensity Rank

HUE: Dom. Wavelength Rank

REF: Forward Voltage Rank

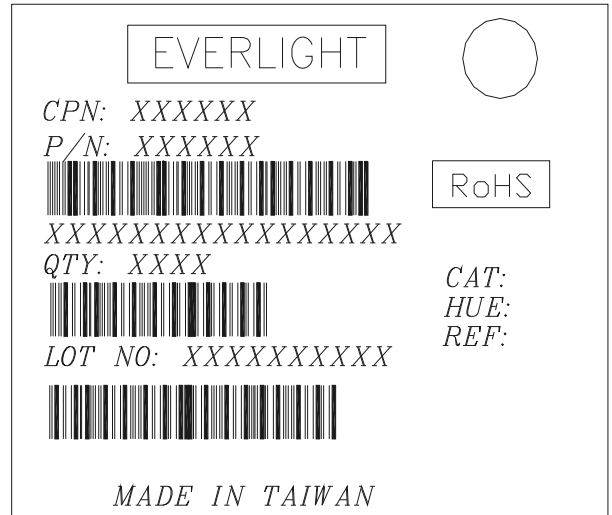

**Reel Dimensions**

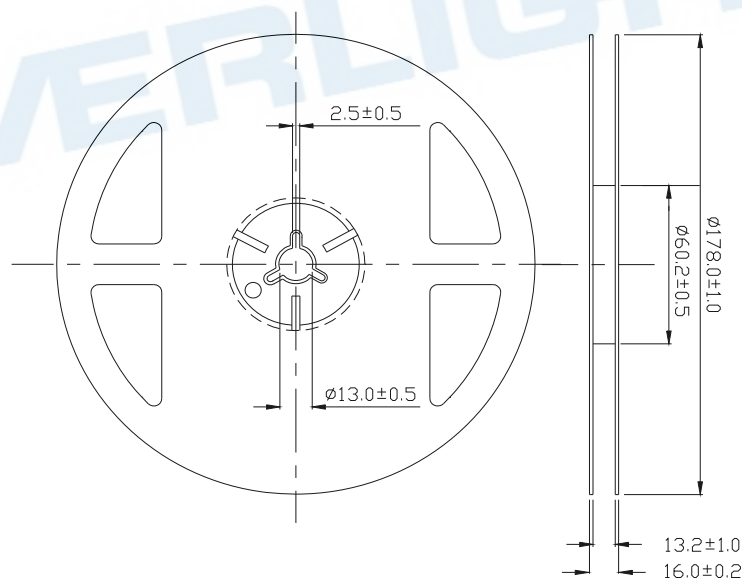

**Note:** The tolerance unless mentioned is ±0.1mm , Unit = mm

**Technical Data Sheet**

**Side View White LED (0.6mm)**

**99-216/B7C-AS1T2N/2C**

**Carrier Tape Dimensions: Loaded Quantity 250 up/500/1000/2000 pcs Per Reel**

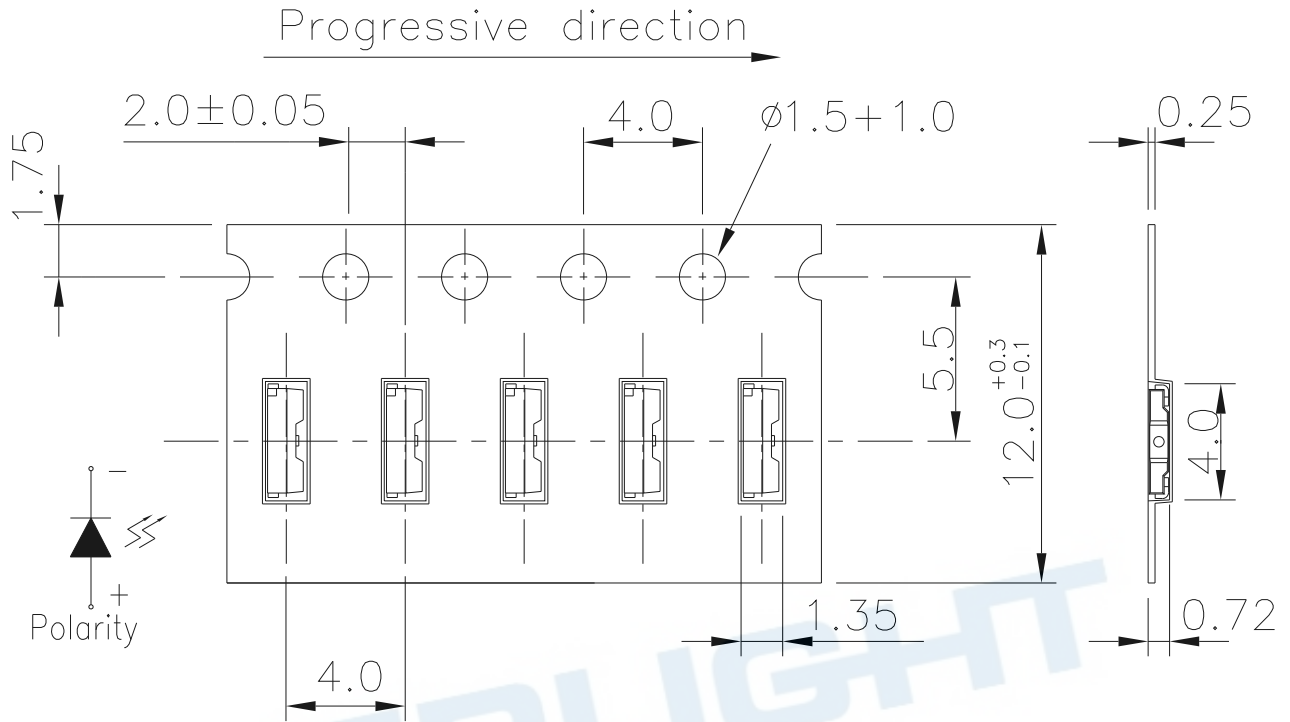

**Note:** The tolerance unless mentioned is ±0.1mm , Unit = mm

**Moisture Resistant Packaging**

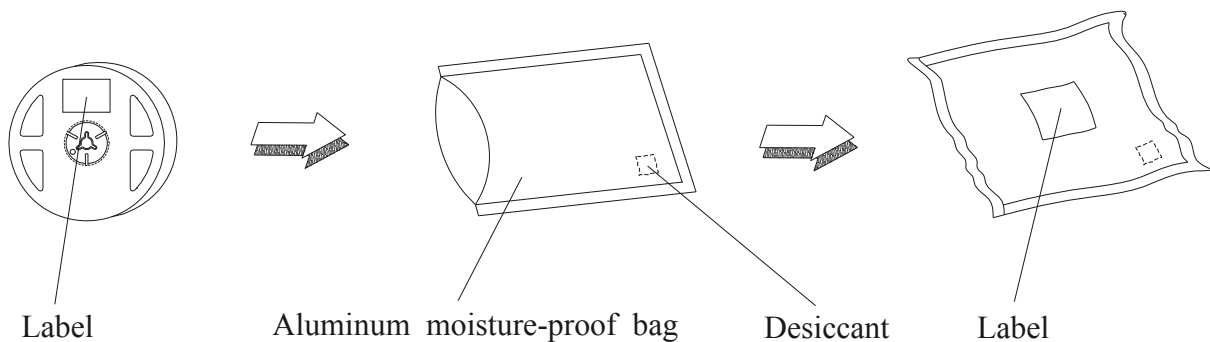

**Technical Data Sheet****Side View White LED (0.6mm)****99-216/B7C-AS1T2N/2C****Reliability Test Items And Conditions**

The reliability of products shall be satisfied with items listed below.

Confidence level : 90%

LTPD : 10%

No.	Items	Test Condition	Test Hours/Cycles	Sample Size	Ac/Re
1	Reflow Soldering	Temp. : 260°C±5°C Max. 10 sec.	6 Min.	22 PCS	0/1
2	Temperature Cycle	H : +100°C 15min ∫ 5 min L : -40°C 15min	300 Cycles	22 PCS.	0/1
3	Thermal Shock	H : +100°C 5min ∫ 10 sec L : -10°C 5min	300 Cycles	22 PCS.	0/1
4	High Temperature Storage	Temp. : 100°C	1000 Hrs.	22 PCS.	0/1
5	Low Temperature Storage	Temp. : -40°C	1000 Hrs.	22 PCS.	0/1
6	DC Operating Life	I <sub>F</sub> = 20 mA / 25°C	1000 Hrs.	22 PCS.	0/1
7	High Temperature / High Humidity	85°C/85%RH	1000 Hrs.	22 PCS.	0/1



**Technical Data Sheet**

**Side View White LED (0.6mm)**

**99-216/B7C-AS1T2N/2C**

**Precautions For Use**

1. Over-current-proof

Customer must apply resistors for protection, otherwise slight voltage shift will cause big current change ( Burn out will happen ).

2. Storage

- 2.1 Do not open moisture proof bag before the products are ready to use.
- 2.2 Before opening the package: The LEDs should be kept at 30°C or less and 90%RH or less.
- 2.3 After opening the package: The LED's floor life is 1 year under 30°C or less and 60% RH or less. If unused LEDs remain, it should be stored in moisture proof packages.
- 2.4 If the moisture absorbent material (silica gel) has faded away or the LEDs have exceeded the storage time, baking treatment should be performed using the following conditions.  
Baking treatment : 60±5°C for 24 hours.

3. Soldering Condition

3.1 Pb-free solder temperature profile

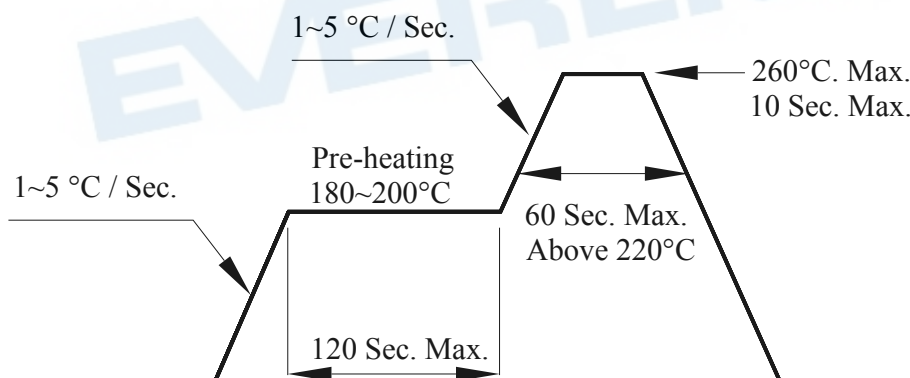

- 3.2 Reflow soldering should not be done more than two times.
- 3.3 When soldering, do not put stress on the LEDs during heating.
- 3.4 After soldering, do not warp the circuit board.

## Technical Data Sheet

### Side View White LED (0.6mm)

99-216/B7C-AS1T2N/2C

#### 4. Soldering Iron

Each terminal is to go to the tip of soldering iron temperature less than 350°C for 3 seconds within once in less than the soldering iron capacity 25W. Leave two seconds and more intervals, and do soldering of each terminal. Be careful because the damage of the product is often started at the time of the hand solder.

#### 5. Repairing

Repair should not be done after the LEDs have been soldered. When repairing is unavoidable, a double-head soldering iron should be used (as below figure). It should be confirmed beforehand whether the characteristics of the LEDs will or will not be damaged by repairing.

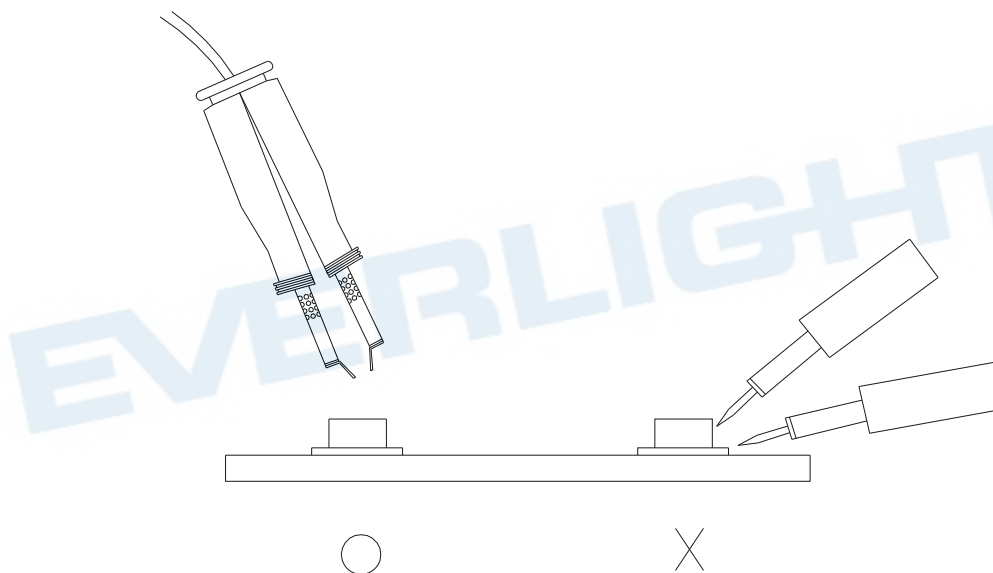

#### 6. Handling Indications

During processing, mechanical stress on the surface should be minimized as much as possible. Sharp objects of all types should not be used to pierce the sealing compound

**Technical Data Sheet**

**Side View White LED (0.6mm)**

**99-216/B7C-AS1T2N/2C**

**DISCLAIMER**

1. EVERLIGHT reserves the right(s) on the adjustment of product material mix for the specification.
2. The product meets EVERLIGHT published specification for a period of twelve (12) months from date of shipment.
3. The graphs shown in this datasheet are representing typical data only and do not show guaranteed values.
4. When using this product, please observe the absolute maximum ratings and the instructions for using outlined in these specification sheets. EVERLIGHT assumes no responsibility for any damage resulting from the use of the product which does not comply with the absolute maximum ratings and the instructions included in these specification sheets.
5. These specification sheets include materials protected under copyright of EVERLIGHT. Reproduction in any form is prohibited without obtaining EVERLIGHT's prior consent.
6. This product is not intended to be used for military, aircraft, automotive, medical, life sustaining or life saving applications or any other application which can result in human injury or death. Please contact authorized Everlight sales agent for special application request.

**EVERLIGHT ELECTRONICS CO., LTD.**

Office: No 25, Lane 76, Sec 3, Chung Yang Rd,  
Tucheng, Taipei 236, Taiwan, R.O.C

Tel: 886-2-2267-2000, 2267-9936

Fax: 886-2267-6244, 2267-6189, 2267-6306

<http://www.everlight.com>