

SMD ■ Side View LEDs

99-218GLM2C/4048NFL/TR8-T(TS)

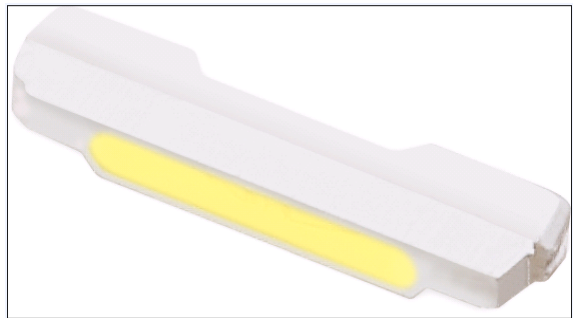

Features

- Side view white LED
- White SMT package
- Lead frame package with individual 2 pins
- Wide viewing angle
- Soldering methods: IR reflow soldering
- Pb-free
- The product itself will remain within RoHS compliant version.

Descriptions

- Due to the package design, 99-218G has wide viewing angle, low power consumption and white LEDs are devices that are materialized by combing blue chips and special phosphor. This feature makes the LED ideal for light guide application.

Applications

- Mobile Phones
- Indicators
- Illuminations
- Switch Light
- Mobile Keyboard
- Compliance with EU REACH.

Coding:

99-218GLM2C/XX XX XX X/TR8-T

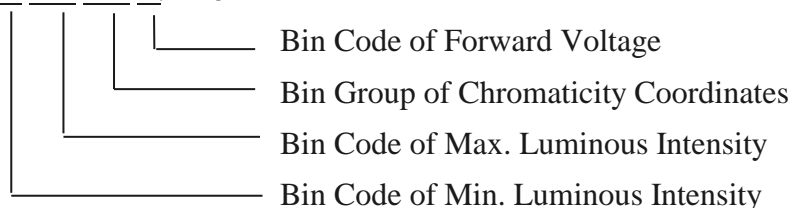

Device Selection Guide

Chip	Emitted Color	Resin Color
InGaN	Pure White	Water Clear

Absolute Maximum Ratings (Ta=25°C)

Parameter	Symbol	Rating	Unit
Reverse Voltage	V_R	5	V
Forward Current	I_F	30	mA
Peak Forward Current (Duty 1/10 @10ms)	I_{FP}	60	mA
Power Dissipation	P_d	110	mW
Operating Temperature	T_{opr}	-40 ~ +85	°C
Storage Temperature	T_{stg}	-40 ~ +90	°C
Soldering Temperature	T_{sol}	Reflow Soldering : 260 °C for 10 sec. Hand Soldering : 350 °C for 3 sec.	

Notes: *1The products are sensitive to static electricity and must be carefully taken when handling products.

Electro-Optical Characteristics (Ta=25°C)

Parameter	Symbol	Min.	Typ.	Max.	Unit	Condition
Luminous Intensity	Φ	2100	-----	2900	mcd	IF=20mA
Viewing Angle	2 θ 1/2	-----	120	-----	deg	
Forward Voltage	V _F	2.80	-----	3.50	V	
Reverse Current	I _R	-----	-----	50	μ A	V _R =5V

Notes:

1. Tolerance of Luminous Intensity: $\pm 7\%$
2. Tolerance of Forward Voltage: $\pm 0.05V$

EVERLIGHT

Bin Range of Luminous Intensity

Bin Code	Mcd(Min.)	Mcd(Max.)	Unit	Condition
40	2100	2150	mcd	I _F =20mA
41	2150	2200		
42	2200	2300		
43	2300	2400		
44	2400	2500		
45	2500	2600		
46	2600	2700		
47	2700	2800		
48	2800	2900		

Note: Tolerance of Luminous Intensity : $\pm 7\%$

Bin Range of Forward Voltage

Group	Bin Code	Min.	Max.	Unit	Condition
L	5-1-3	2.8	2.9	V	I _F =20mA
	5-2-3	2.9	3.0		
	6-1-3	3.0	3.1		
	6-2-3	3.1	3.2		
	7-1-3	3.2	3.3		
	7-2-3	3.3	3.4		
	8-1-3	3.4	3.5		

Note: Tolerance of Forward Voltage: $\pm 0.05V$

EVERLIGHT

Chromaticity Coordinates of Bin Code

Bin Code	CIE_x	CIE_y	Bin Code	CIE_x	CIE_y
NA0-3-1	0.2760	0.2530	NA0-3-2	0.2805	0.2600
	0.2720	0.2580		0.2770	0.2650
	0.2770	0.2650		0.2820	0.2720
	0.2805	0.2600		0.2850	0.2670
NA0-3-3	0.2800	0.2480	NA0-3-4	0.2840	0.2550
	0.2760	0.2530		0.2805	0.2600
	0.2805	0.2600		0.2850	0.2670
	0.2840	0.2550		0.2880	0.2620
NA0-4-1	0.2850	0.2670	NA0-4-2	0.2893	0.2743
	0.2820	0.2720		0.2865	0.2795
	0.2865	0.2795		0.2910	0.2870
	0.2893	0.2743		0.2935	0.2815
NA0-4-3	0.2880	0.2620	NA0-4-4	0.2920	0.2690
	0.2850	0.2670		0.2893	0.2743
	0.2893	0.2743		0.2935	0.2815
	0.2920	0.2690		0.2960	0.2760
NB5-3-1	0.2935	0.2815	NB5-3-3	0.2960	0.2760
	0.2910	0.2870		0.2935	0.2815
	0.2950	0.2940		0.2975	0.2885
	0.2975	0.2885		0.3000	0.2830

Note: Tolerance of Chromaticity Coordinates: ± 0.01

Chromaticity Coordinates of Bin Code

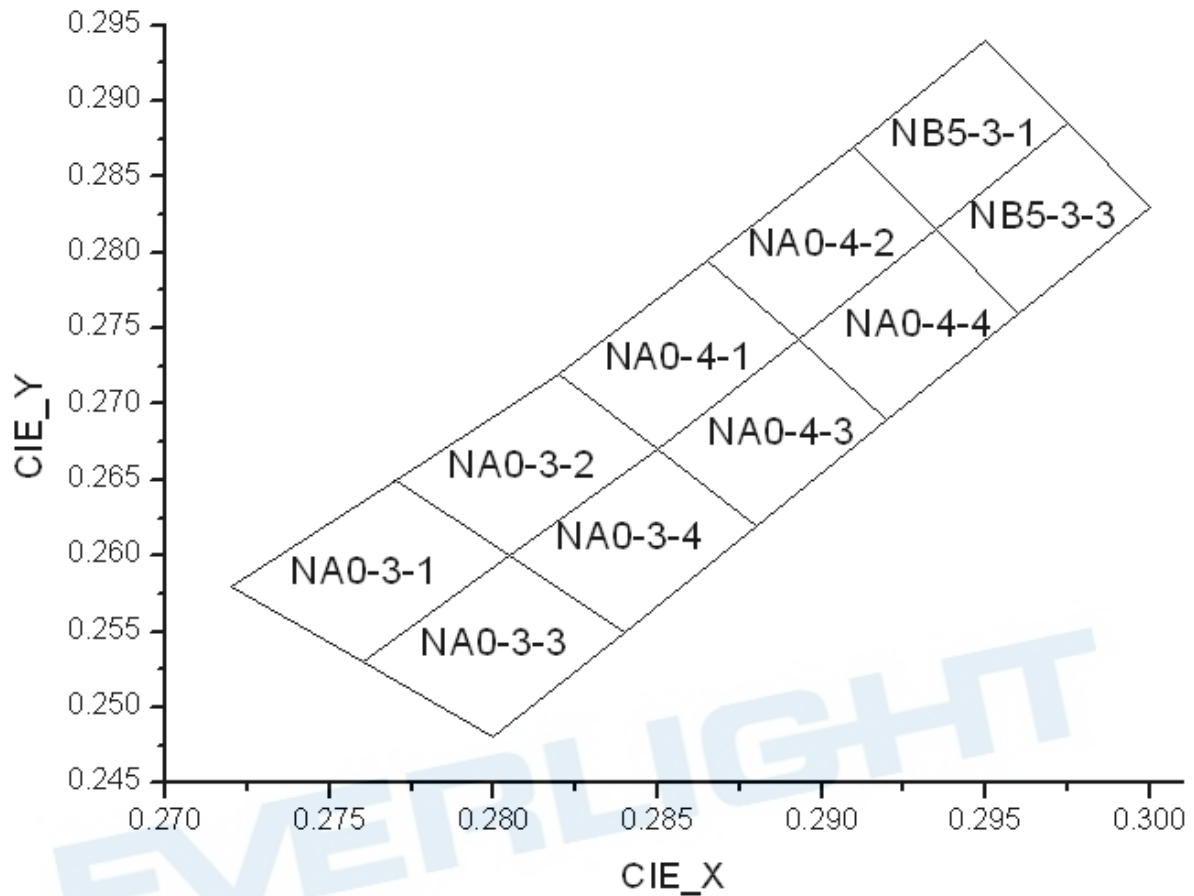

Package Outline Dimensions

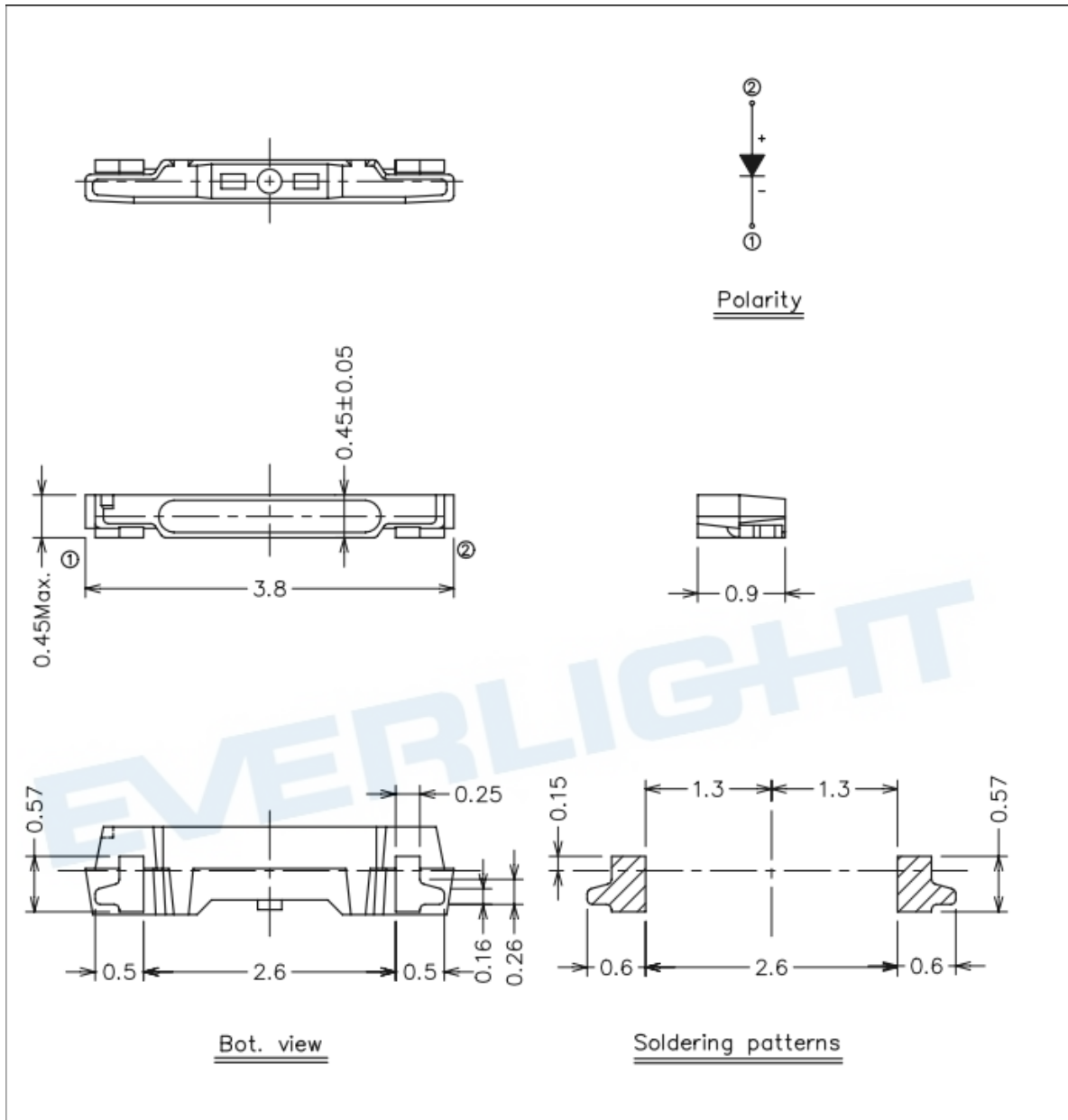

Note: The tolerances unless dimensions are ± 0.1 mm.

1. Spectrum Distribution

($T_A=25^{\circ}\text{C}$, $I_F=20\text{mA}$)

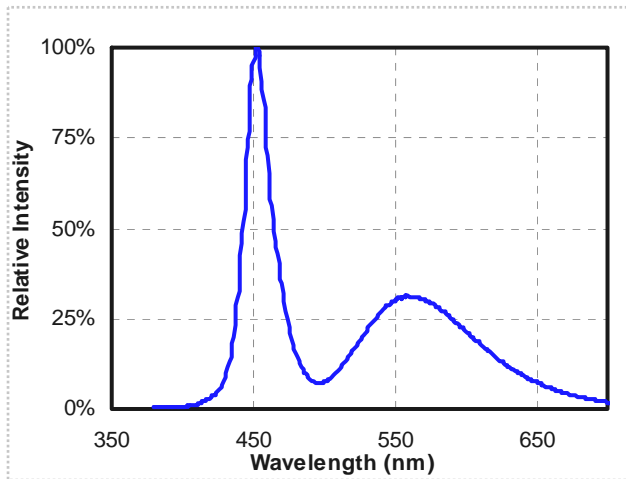

2. Relative Luminous Intensity vs. Forward Current

($T_A=25^{\circ}\text{C}$)

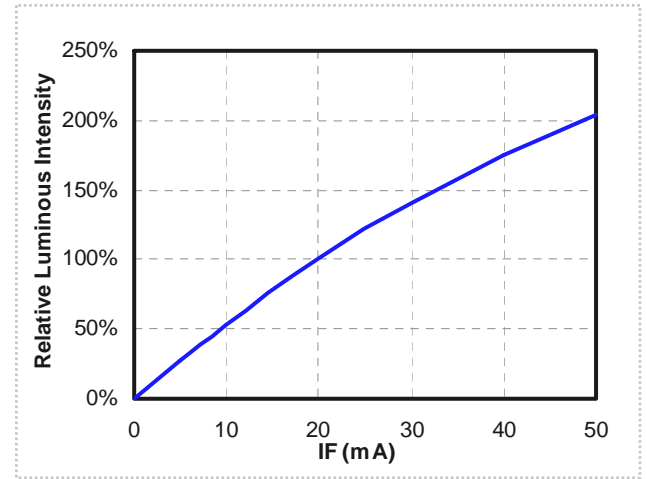

3. Relative Forward Voltage vs. Forward Current

($T_A=25^{\circ}\text{C}$)

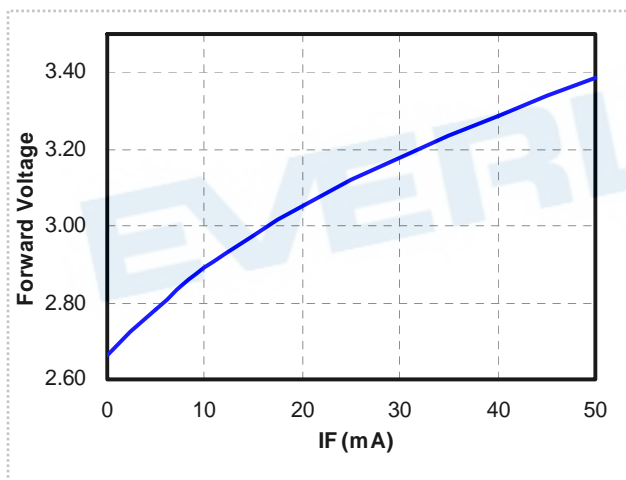

4. Radiation Diagram

($T_A=25^{\circ}\text{C}$, $I_F=20\text{mA}$)

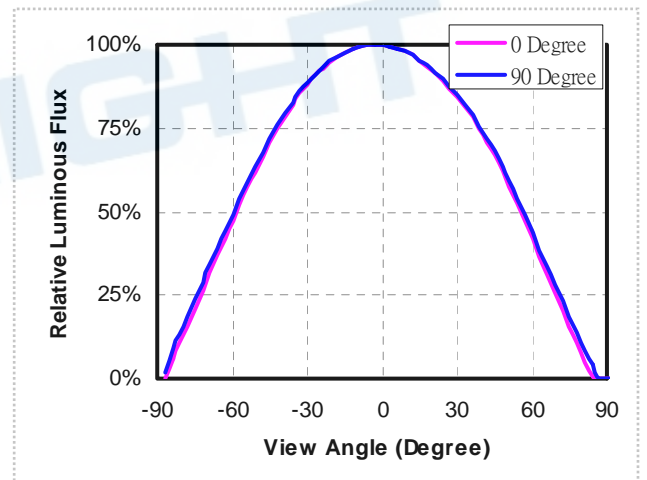

Typical Electro-Optical-Thermal Characteristics Curves

5. Relative Luminous Intensity vs. Solder Temperature
 ($I_F=20\text{mA}$)

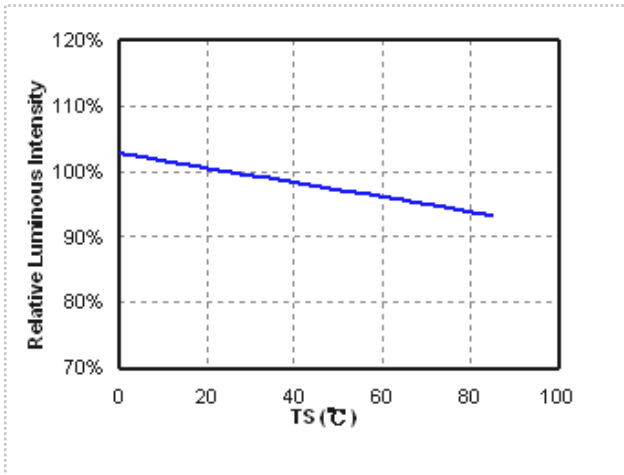

6. Forward Voltage vs. Solder Temperature
 ($I_F=20\text{mA}$)

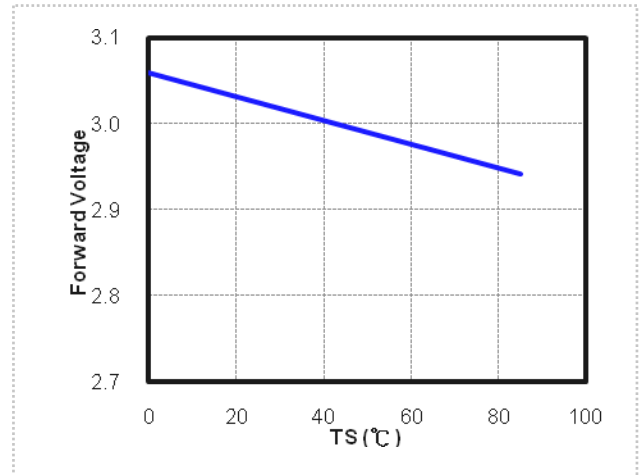

7. Chromaticity Coordinates vs. Solder Temperature
 ($I_F=20\text{mA}$)

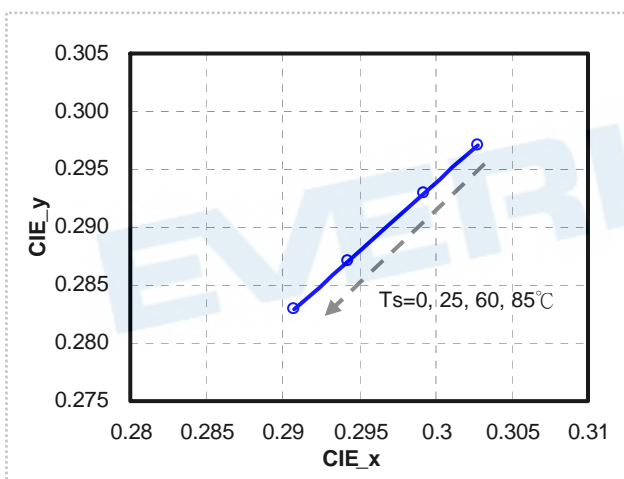

8. Forward Current De-rating Curve

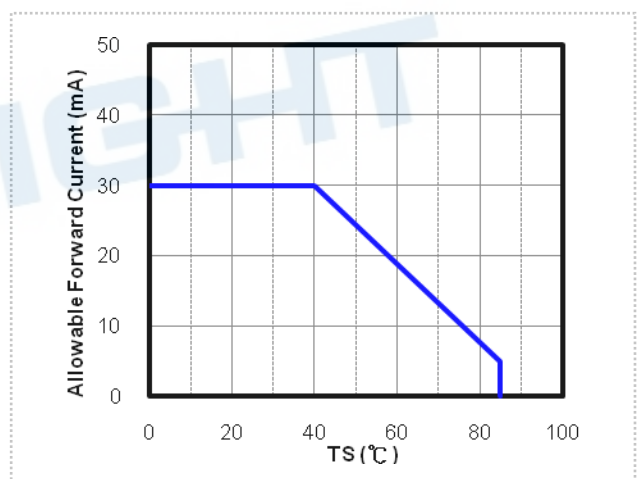

Label Explanation

CAT: Luminous Intensity Rank
 HUE: Chromaticity Coordinates
 REF: Forward Voltage Rank

RoHS		EVERLIGHT	5
------	--	------------------	---

CPN: XXXXXXXXXXXXXXXXXXXXXXXX 測試區
 XXXXXXXXXXX-XXXXXXXX-XXXXXXXX-XXXXXXXX-XXXXXX
 P/N: XXXXXXXXXXX
 XXXXXXXXXXX-XXXXXXXX-XXXXXXXX-XXXXXXXX-XXXXXX
 LOT NO: Y150716XXX-XXXXXXXX-XXXXXXXX
 QTY: 0123456789 HUE: XXXXXXXXXXX
 CAT: XXXXXXXXXXX REF: XXXXXXXXXXX
 REFERENCE: BTPYYMDDXXXX
 MSL-2a MADE IN TAIWAN



Reel Dimensions

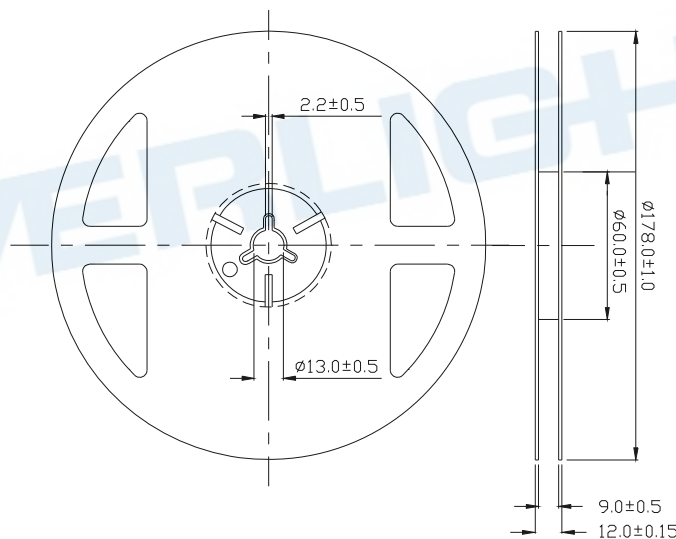

Note: The tolerances unless dimension are ± 0.1mm.

**Carrier Tape Dimensions: Loaded Quantity 1000、2000、3000、4000 pcs.
 Per Reel**

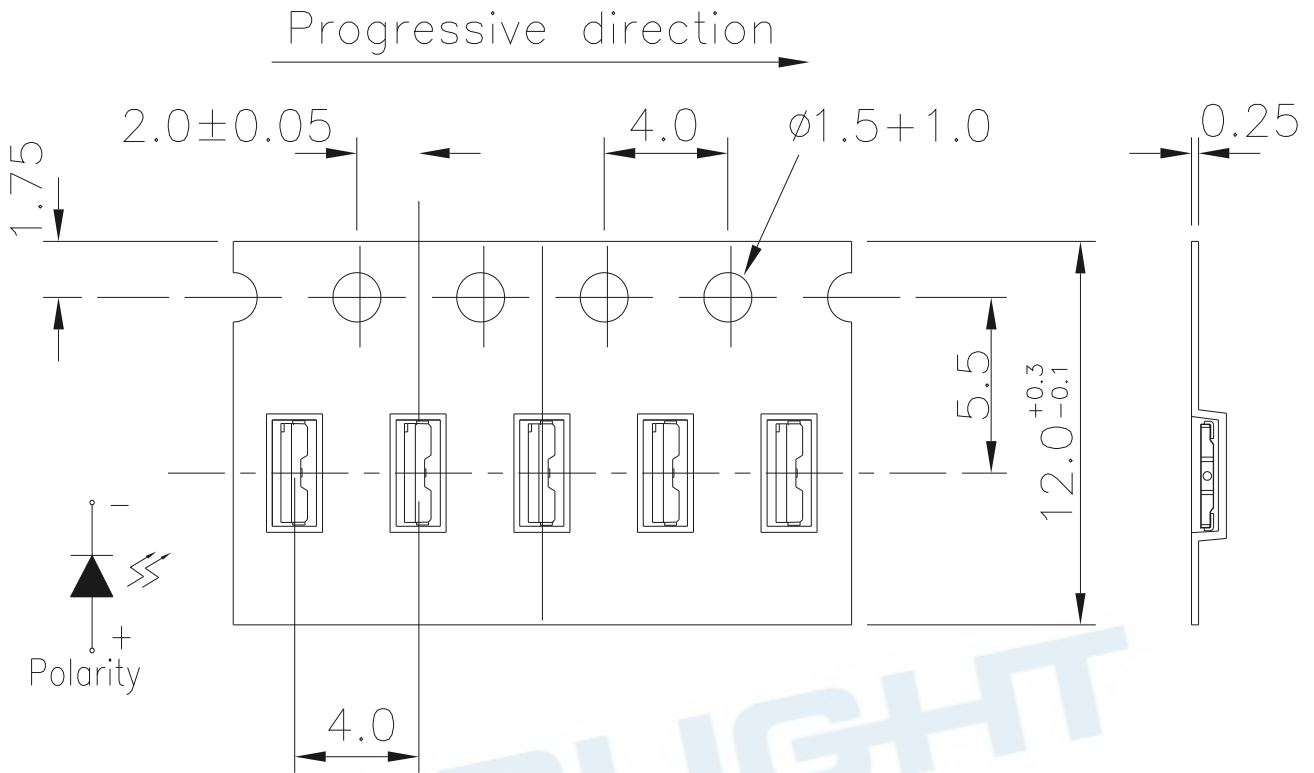

Note: The tolerances unless mentioned is ±0.1mm, Unit = mm.

Moisture Resistant Packaging

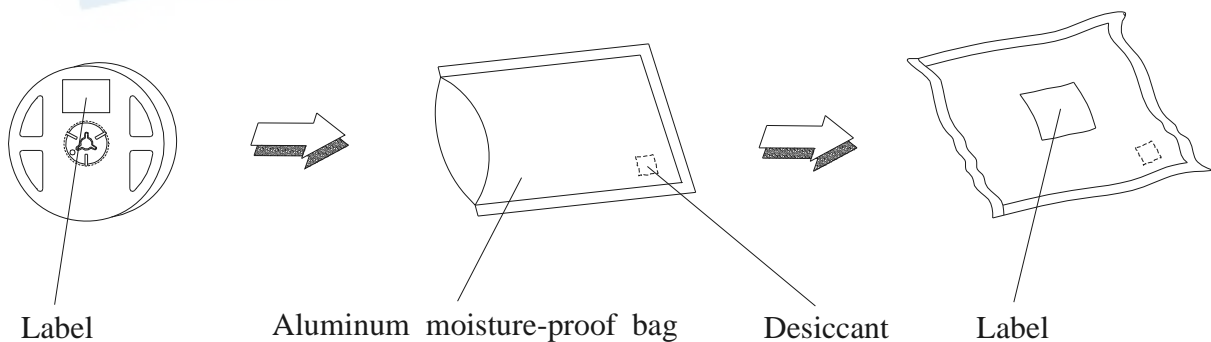

Note: Actual photo of standard packing bag

Reliability Test Items and Conditions

The reliability of products shall be satisfied with items listed below.

Confidence level : 90%

LTPD : 10%

NO	Item	Test Condition		Test Hours / Times	Criteria	
		Temp./ Humidity	I _F (mA)		I _v @ 20mA	V _F @ 20mA
1	Reflow Soldering	T _{Sld} = 260°C, Max. 10sec.		2 times	<±5%	<±5%
2	Temperature Cycle	-40°C 30min.	~ (5min.)	100°C 30min.	200 cycles	I _v > 70%, V _F < 110%,
3	Thermal Shock	-10°C 20min.	~ (<15sec.)	100°C 20min.	200 cycles	
4	Low Temp. Storage	T _a = -40°C	--	1000 hrs		
5	High Temp. Storage	T _a = 100°C	--	1000 hrs		
6	Temp. Humidity Storage	T _a = 60°C / 90%RH	--	1000 hrs		
7	Steady State Operating Life of Low Temp.	T _a = -40°C	20	1000 hrs		
8	Steady State Operating Life Condition 1	T _a = 25°C / Room Humidity	20	1000 hrs		
9	Steady State Operating Life Condition 2	T _a = 60°C	20	1000 hrs		
10	Steady State Operating Life of High Temp.	T _a = 85°C	5	1000 hrs		
11	Steady State Operating Life of High Humidity Heat	T _a = 60°C / 90%RH	20	1000 hrs		

Precautions for Use

1. Over-current-proof

Customer must apply resistors for protection, otherwise slight voltage shift will cause big current change (Burn out will happen).

2. Storage

2.1 Do not open moisture proof bag before the products are ready to use.

2.2 Before opening the package: The LEDs should be used within one year and kept at 30°C or less and 70%RH or less.

2.3 After opening the package: We recommend that the LED should be soldered quickly (within 3 days). The soldering condition is 30°C or less and 60%RH or less. If unused LEDs remain, it should be stored in moisture proof packages.

2.4 If the moisture absorbent material (silica gel) has faded away or the LEDs have exceeded the storage time, baking treatment should be performed using the following conditions. Baking treatment: 60±5°C for 24 hours. (One time only)

3. Soldering Condition

3.1 Pb-free solder temperature profile

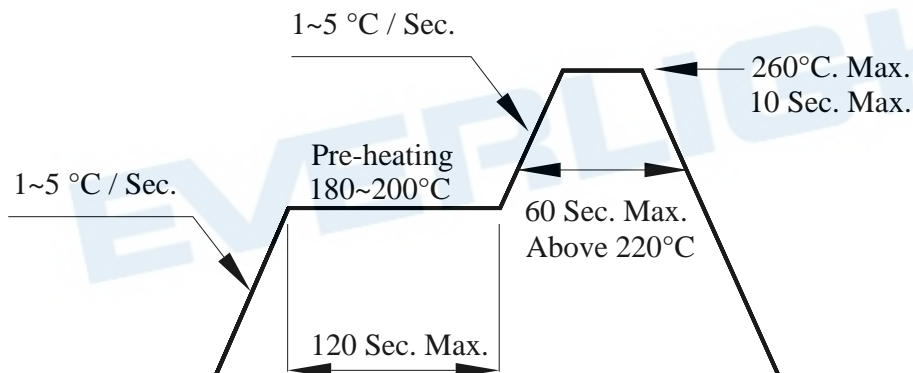

3.2 Reflow soldering should not be done more than two times.

3.3 When soldering, do not put stress on the LEDs during heating.

3.4 After soldering, do not warp the circuit board.

4. Soldering Iron

Each terminal is to go to the tip of soldering iron temperature less than 350°C for 3 seconds within once in less than the soldering iron capacity 25W. Leave two seconds and more intervals, and do soldering of each terminal. Be careful because the damage of the product is often started at the time of the hand solder.

5. Repairing

Repair should not be done after the LEDs have been soldered. When repairing is unavoidable, a double-head soldering iron should be used (as below figure). It should be confirmed beforehand whether the characteristics of the LEDs will or will not be damaged by repairing.

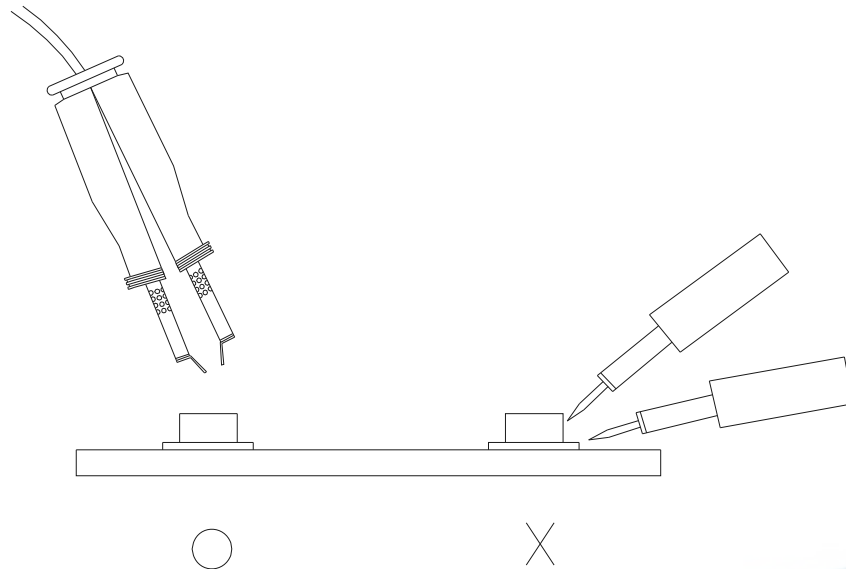

6. Handling Indications

During processing, mechanical stress on the surface should be minimized as much as possible. Sharp objects of all types should not be used to pierce the sealing compound.