

## WG65R330L

### Features

- Ultra Low  $R_{DS(ON)} = 330m\Omega @ V_{GS} = 10V$ .
- Ultra Low Gate Charge,  $Q_g=30 nC$  typ.
- Fast switching capability
- Robust design with better EAS performance
- EMI Improved Design

### Package Type



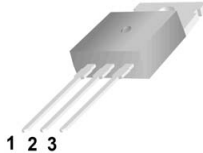

1 2 3  
WG65R330L

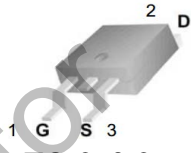

1 G S 3 2 D  
TO-263-2  
WGB65R330L



1 2 3  
TO-220F  
WGF65R330L

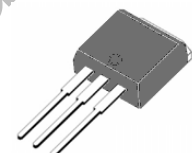

1 2 3  
TO-262  
WGI65R330L

### 极限参数(除非特殊说明, $T_C=25^\circ C$ )

参数名称	符号	参数范围				单位
		TO-220	TO-220F	TO-262	TO-263	
漏源电压	$V_{DS}$	650				V
栅源电压	$V_{GS}$	$\pm 30$				V
漏极电流	$I_D$	$T_C=25^\circ C$				A
		11				
		$T_C=100^\circ C$				
		6.7				
漏极脉冲电流	$I_{DM}$	44				A
耗散功率( $T_C=25^\circ C$ ) - 大于 $25^\circ C$ 每摄氏度减少	$P_D$	86	23	79	82	W
		0.69	0.18	0.63	0.66	W/ $^\circ C$
单脉冲雪崩能量 (注 1)	$E_{AS}$	250				mJ
工作结温范围	$T_J$	$-55 \sim +150$				$^\circ C$
贮存温度范围	$T_{stg}$	$-55 \sim +150$				$^\circ C$

参数名称	符号	参数范围				单位
		TO-220	TO-220F	TO-262	TO-263	
芯片对管壳热阻	$R_{\theta JC}$	1.45	5.43	1.58	1.52	$^{\circ}\text{C}/\text{W}$
芯片对环境的热阻	$R_{\theta JA}$	62.5				$^{\circ}\text{C}/\text{W}$

### 电气参数(除非特殊说明, $T_c=25^{\circ}\text{C}$ )

参数	符号	测试条件	最小值	典型值	最大值	单位
漏源击穿电压	$BV_{DSS}$	$V_{GS}=0\text{V}$ , $I_D=250\mu\text{A}$	650	--	--	V
漏源漏电流	$I_{DSS}$	$V_{DS}=650\text{V}$ , $V_{GS}=0\text{V}$	--	--	1.0	$\mu\text{A}$
栅源漏电流	$I_{GSS}$	$V_{GS}=\pm 30\text{V}$ , $V_{DS}=0\text{V}$	--	--	$\pm 100$	nA
栅极开启电压	$V_{GS(th)}$	$V_{GS}=V_{DS}$ , $I_D=250\mu\text{A}$	2.0	--	4.0	V
静态漏源导通电阻	$R_{DS(on)}$	$V_{GS}=10\text{V}$ , $I_D=5.5\text{A}$	--	--	0.33	$\Omega$
输入电容	$C_{iss}$	$V_{DS}=100\text{V}$ , $V_{GS}=0\text{V}$ , $f=1.0\text{MHz}$	--	850	--	pF
输出电容	$C_{oss}$		--	50	--	
反向传输电容	$C_{rss}$		--	1.8	--	
开启延迟时间	$t_{d(on)}$	$V_{DD}=325\text{V}$ , $V_{GS}=10\text{V}$ , $R_G=10\Omega$ , $I_D=11\text{A}$ (注 2,3)	--	14	--	ns
开启上升时间	$t_r$		--	33	--	
关断延迟时间	$t_{d(off)}$		--	54	--	
关断下降时间	$t_f$		--	30	--	
栅极电荷量	$Q_g$	$V_{DD}=520\text{V}$ , $V_{GS}=10\text{V}$ , $I_D=11\text{A}$ (注 2,3)	--	30	--	nC
栅极-源极电荷量	$Q_{gs}$		--	5.0	--	
栅极-漏极电荷量	$Q_{gd}$		--	15	--	

### 源-漏二极管特性参数

参数	符号	测试条件	最小值	典型值	最大值	单位
连续源极电流	$I_S$	MOS管中源极、漏极构成的 反偏 P-N 结	--	--	11	A
源极脉冲电流	$I_{SM}$		--	--	44	
二极管压降	$V_{SD}$	$I_S=11\text{A}$ , $V_{GS}=0\text{V}$	--	--	1.4	V
反向恢复时间	$T_{rr}$	$I_S=11\text{A}$ , $V_{GS}=0\text{V}$ , $di_F/dt=100\text{A}/\mu\text{s}$	--	331	--	ns
反向恢复电荷	$Q_{rr}$		--	4	--	$\mu\text{C}$

注:

1.  $L=30\text{mH}$ ,  $I_{AS}=3.8\text{A}$ ,  $V_{DD}=100\text{V}$ ,  $R_G=25\Omega$ , 开始温度 $T_J=25^{\circ}\text{C}$ ;
2. 脉冲测试: 脉冲宽度 $\leq 300\mu\text{s}$ , 占空比 $\leq 2\%$ ;
3. 基本上不受工作温度的影响。

典型特性曲线

图1. 输出特性



图2. 传输特性



图3. 导通电阻vs.漏极电流

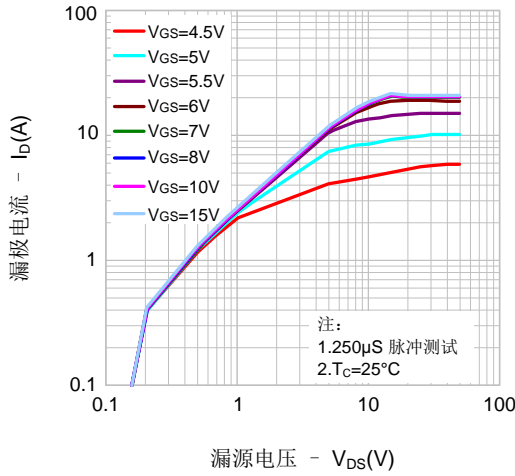

图4. 体二极管正向压降vs. 源极电流、温度

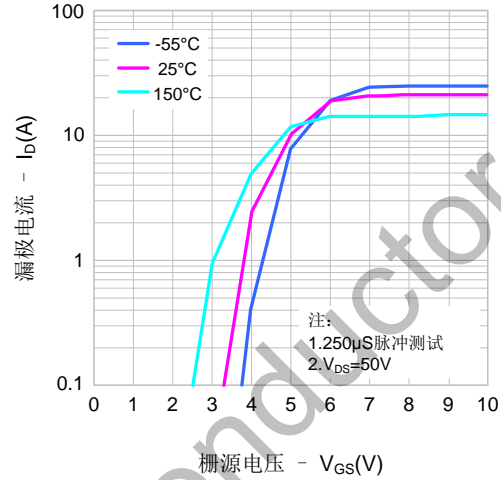

图5. 电容特性

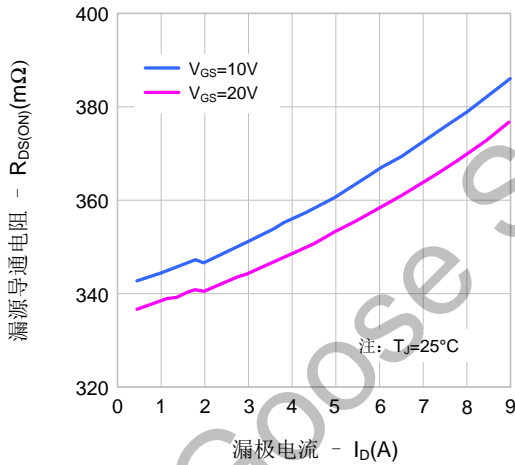

图6. 电荷量特性

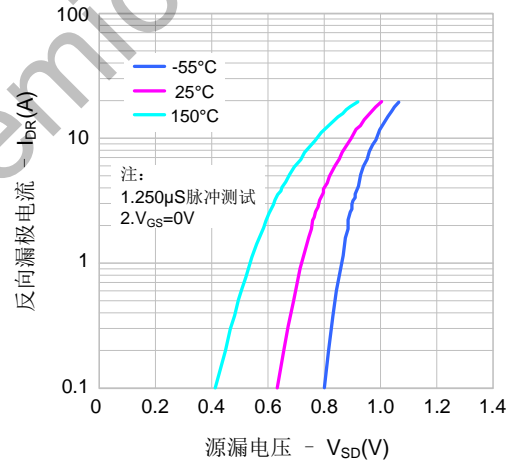

典型特性曲线

图7. 击穿电压vs.温度特性

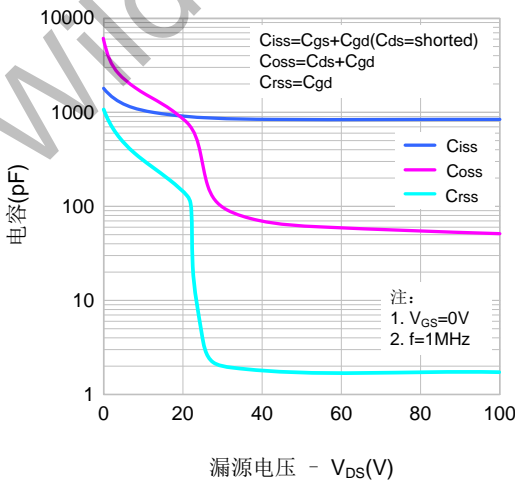
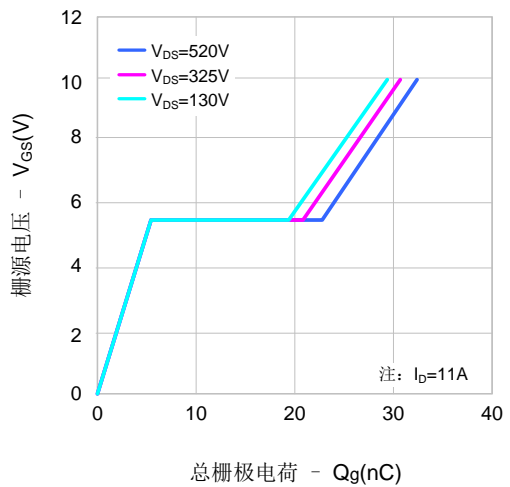

图8. 导通电阻vs.温度特性



图9-1. 最大安全工作区域(SVS11N65T)

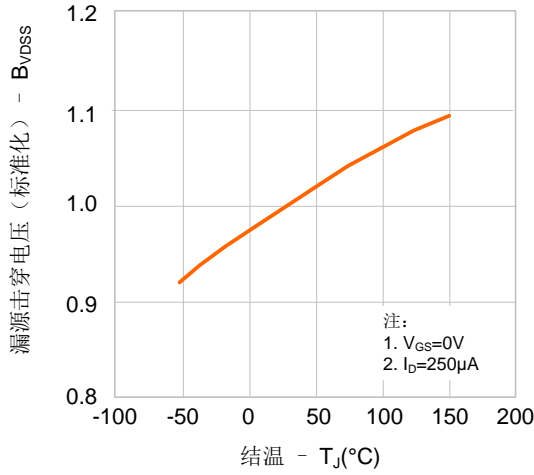

图9-2. 最大安全工作区域(SVS11N65F)

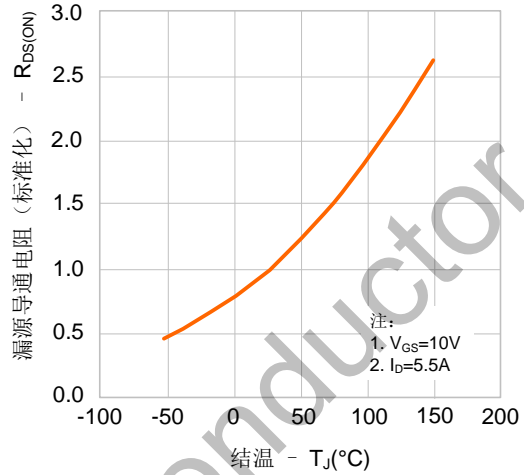

图9-3. 最大安全工作区域(SVS11N65K)

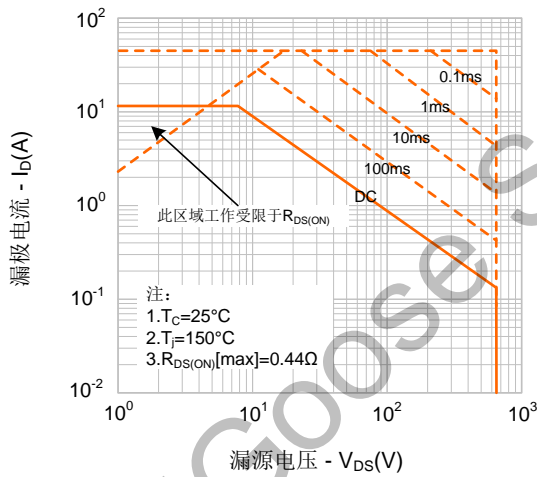

图9-4. 最大安全工作区域(SVS11N65S)

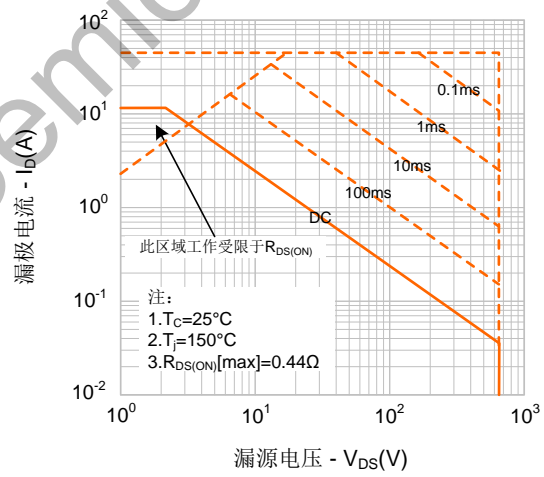

典型测试电路

栅极电荷量测试电路及波形图

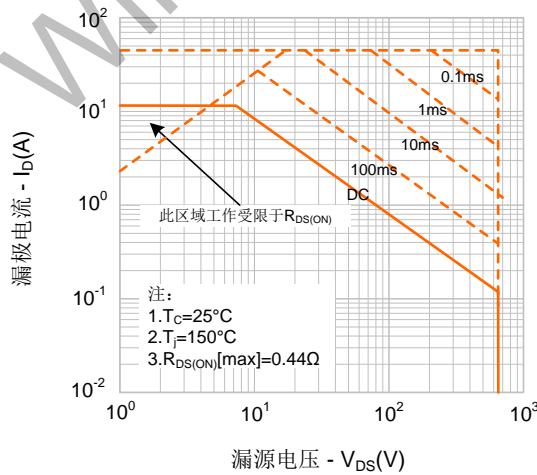
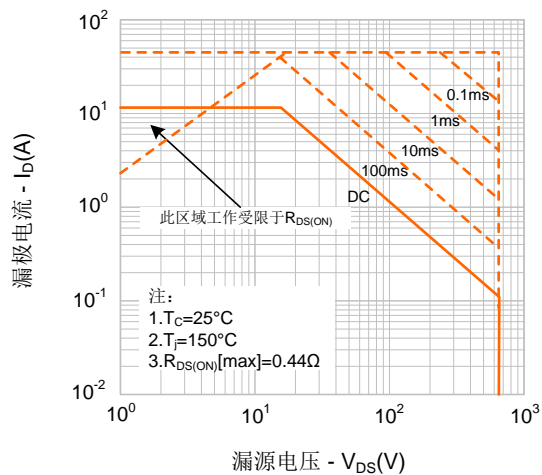
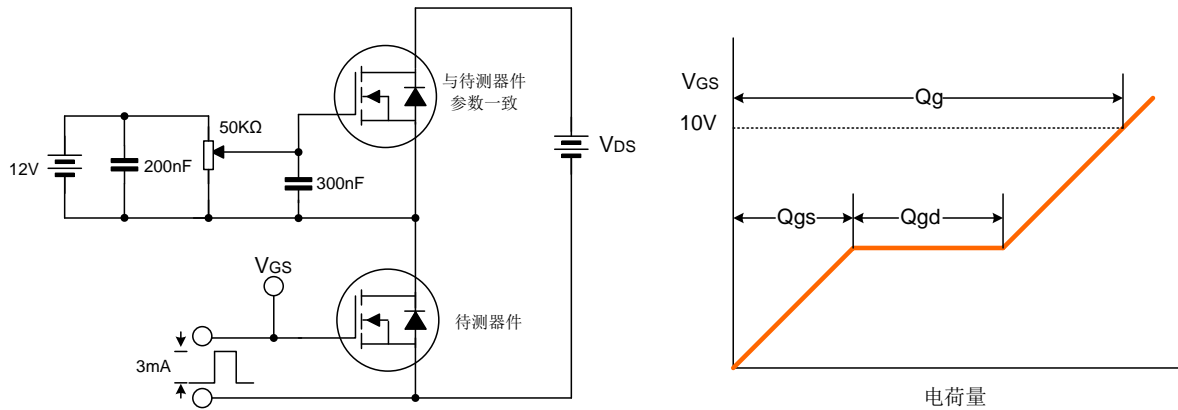

开关时间测试电路及波形图

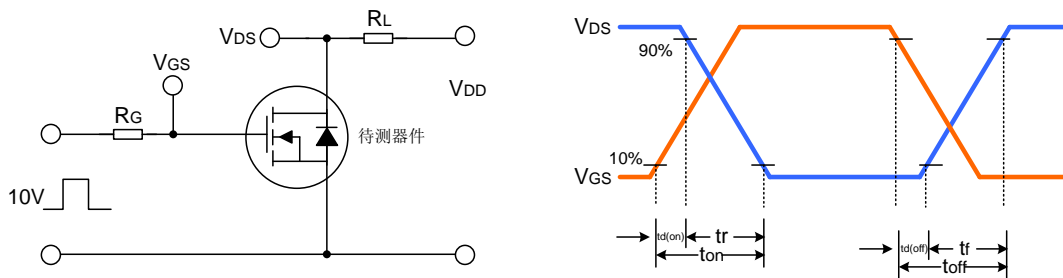

EAS测试电路及波形图

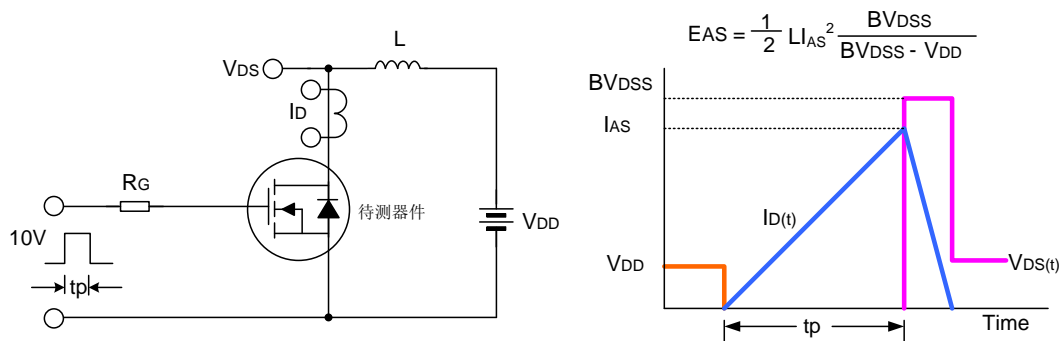

**Package Dimension**

**TO-220**

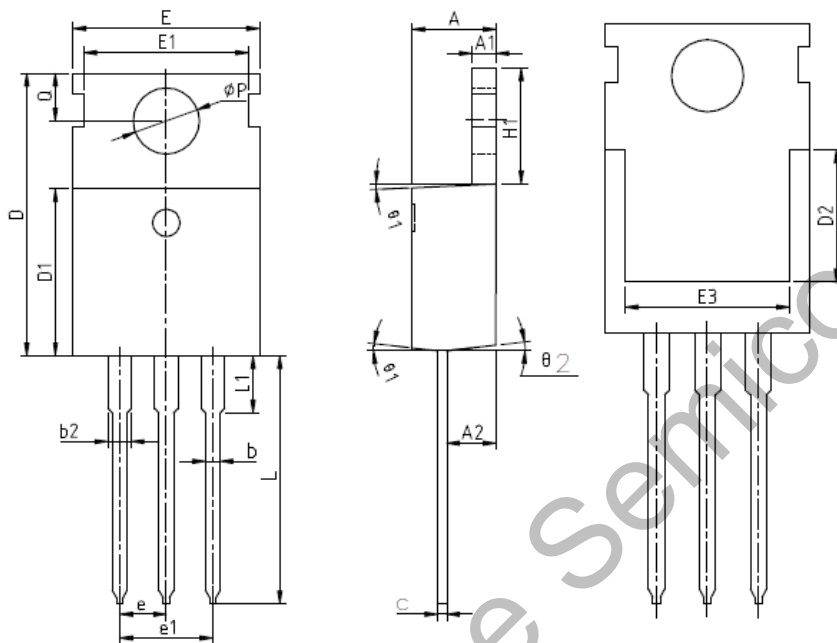

SYMBOL	MIN	NOM	MAX
A	4.27	4.57	4.87
A1	1.15	1.30	1.45
A2	2.10	2.40	2.70
b	0.70	0.80	1.00
b2	1.17	1.27	1.50
e	0.40	0.50	0.65
D	15.10	15.60	16.10
D1	8.80	9.10	9.40
D2	5.70	6.70	7.00
E	9.70	10.00	10.30
E1	-	8.70	-
E2	9.65	10.00	10.35
E3	7.00	8.00	8.40
e	2.54 BSC		
e1	5.08 BSC		
H1	6.00	6.50	6.85
L	12.75	13.50	13.90
L1	-	3.10	3.40
ΦP	3.45	3.60	3.75
Q	2.60	2.80	3.00
θ 1	4°	7°	10°
θ 2	0°	3°	6°

Package Dimension

TO-263

Unit:mm

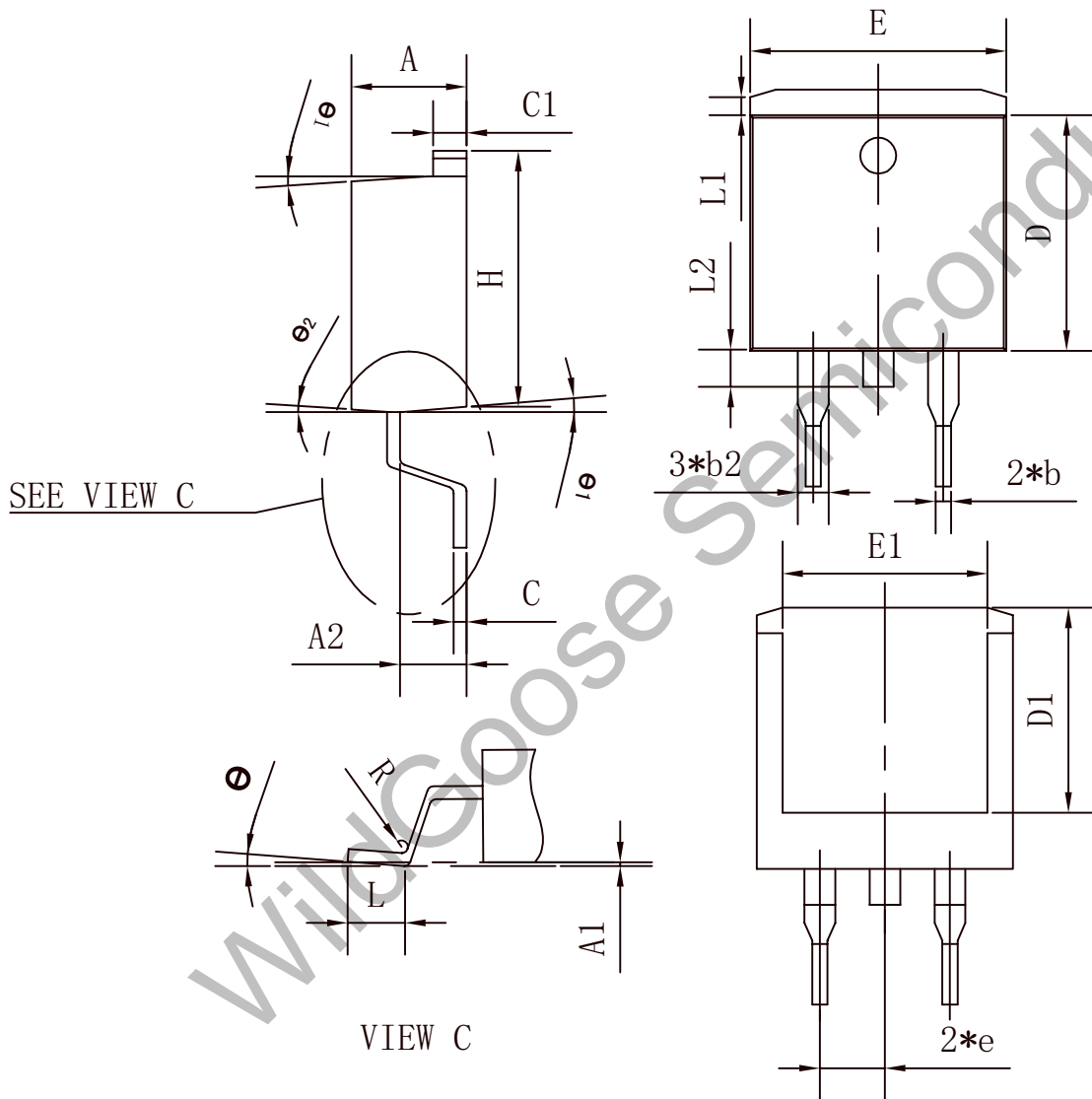

SYMBOL	MIN	NOM	MAX
A	4.35	4.47	4.60
A1	0.09	0.10	0.11
A2	2.30	2.40	2.50
b	0.70	0.80	1.00
b2	1.25	1.36	1.38
C	0.45	0.50	0.55
C1	1.29	1.30	1.31
D	9.10	9.20	9.30
D1	7.90	8.00	8.10
E	9.85	10.00	10.20
E1	7.90	8.00	8.10
H	15.30	15.50	15.70
e	-	2.54	-
L	2.34	2.54	2.74
L1	1.00	1.10	1.20
L2	1.30	1.40	1.50
R	0.24	0.25	0.26
e	0°	4°	8°
e1	4°	7°	10°
e2	0°	3°	6°

Package Dimension

TO-220F

Unit: mm

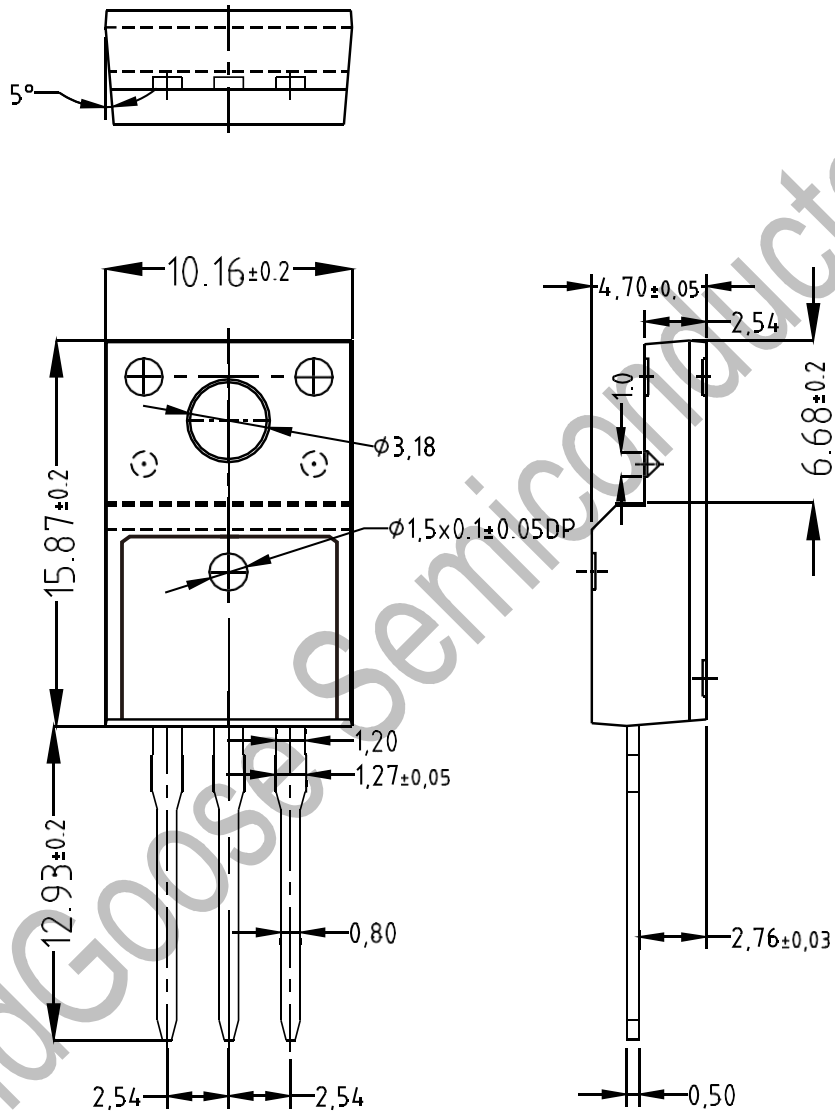



Package Dimension

TO-262

Unit: mm

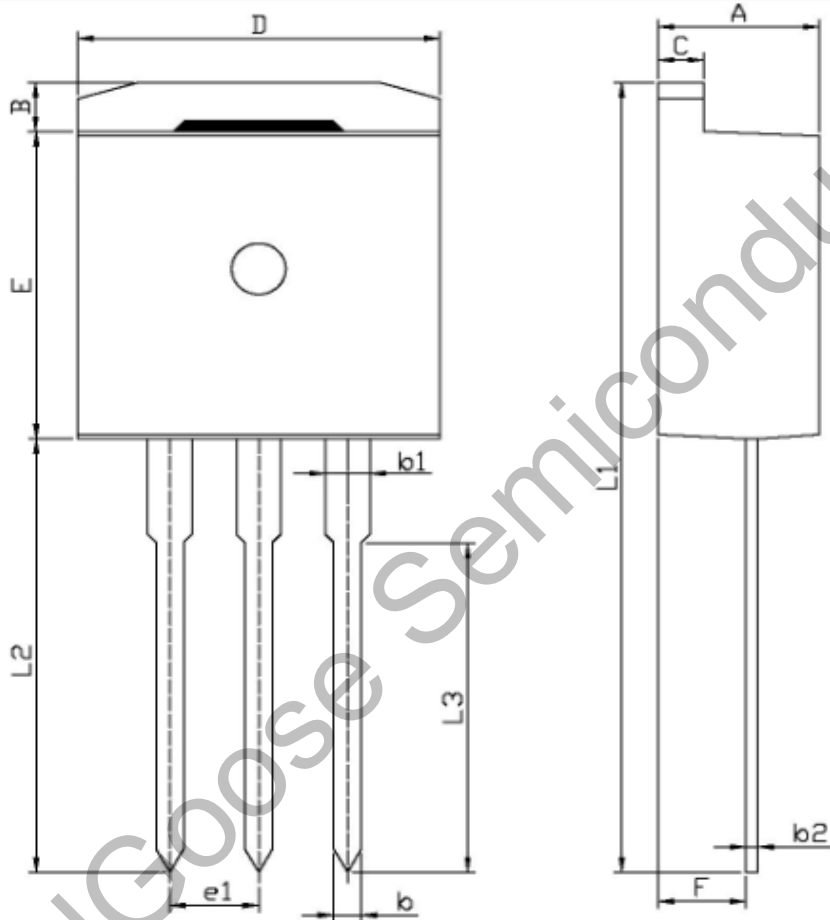

单位: mm

Symbol	Dimensions In Millimeters		Symbol	Dimensions In Millimeters	
	Min	Max		Min	Max
A	4.30	4.70	E	9.00	9.40
B	1.00	1.40	e1	2.34	2.74
b	0.70	0.90	F	2.20	2.60
b1	1.27		L1	22.60	23.60
b2	0.40	0.60	L2	12.60	13.60
C	1.20	1.40	L3	9.60	10.60
D	9.80	10.20			