

# SN74ALS234

## 64 × 4 ASYNCHRONOUS FIRST-IN, FIRST-OUT MEMORY

SDAS106B – OCTOBER 1986 – REVISED SEPTEMBER 1993

- Asynchronous Operation
- Organized as 64 Words by 4 Bits
- Data Rates From 0 to 30 MHz
- 3-State Outputs
- Package Options Include Plastic Small-Outline Packages (DW), Plastic J-Leaded Chip Carriers (FN), and Standard Plastic 300-mil DIPs (N)

### description

The SN74ALS234 is a 256-bit memory utilizing advanced low-power Schottky IMPACT™ technology. It features high speed with fast fall-through times and is organized as 64 words by 4 bits.

A first-in, first-out (FIFO) memory is a storage device that allows data to be written into and read from its array at independent data rates. The SN74ALS234 is designed to process data at rates from 0 to 30 MHz in a bit-parallel format, word by word.

Data is written into memory on the rising edge of the shift-in (SI) input. When SI goes low, the first data word ripples through to the output (see Figure 1). As the FIFO fills up, the data words stack up in the order they were written. When the FIFO is full, additional shift-in pulses have no effect. Data is shifted out of memory on the falling edge of the shift-out (SO) input (see Figure 2). When the FIFO is empty, additional SO pulses have no effect. The last data word remains at the outputs until a new word falls through or reset (RST) goes low.

Status of the SN74ALS234 FIFO memory is monitored by the output-ready (OR) and input-ready (IR) flags. When OR is high, valid data is available at the outputs. OR is low when SO is high and stays low when the FIFO is empty. IR is high when the inputs are ready to receive more data. IR is low when SI is high and stays low when the FIFO is full.

When the FIFO is empty, input data is shifted to the output automatically when SI goes low. If SO is held high during this time, the OR flag pulses high indicating valid data at the outputs (see Figure 3).

When the FIFO is full, data can be shifted in automatically by holding SI high and taking SO low. One propagation delay after SO goes low, IR will go high. If SI is still high when IR goes high, data at the inputs are automatically shifted in. Since IR is normally low when the FIFO is full and SI is high, only a high-level pulse is seen on the IR output (see Figure 4).

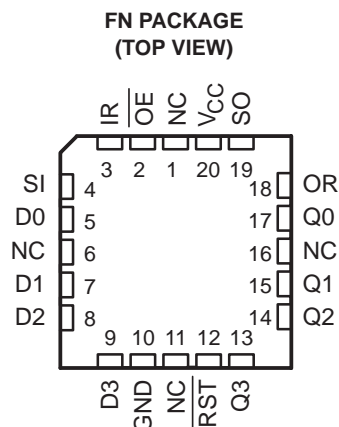
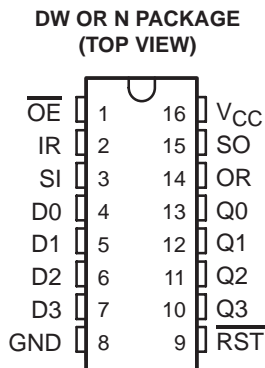

NC – No internal connection



Please be aware that an important notice concerning availability, standard warranty, and use in critical applications of Texas Instruments semiconductor products and disclaimers thereto appears at the end of this data sheet.

IMPACT is a trademark of Texas Instruments Incorporated.

**PRODUCTION DATA** information is current as of publication date. Products conform to specifications per the terms of Texas Instruments standard warranty. Production processing does not necessarily include testing of all parameters.



POST OFFICE BOX 655303 • DALLAS, TEXAS 75265  
POST OFFICE BOX 1443 • HOUSTON, TEXAS 77251-1443

Copyright © 1993, Texas Instruments Incorporated

# SN74ALS234

## 64 × 4 ASYNCHRONOUS FIRST-IN, FIRST-OUT MEMORY

SDAS106B – OCTOBER 1986 – REVISED SEPTEMBER 1993

### description (continued)

The FIFO must be reset after power up with a low-level pulse on the master reset ( $\overline{RST}$ ) input. This sets IR high and OR low signifying that the FIFO is empty. Resetting the FIFO sets the outputs to a low logic level (see Figure 1). If SI is high when  $\overline{RST}$  goes high, the input data is shifted in and IR goes low and remains low until SI goes low. If SI goes low before  $\overline{RST}$  goes high, the input data will not be shifted in and IR goes high. Data outputs are noninverting with respect to the data inputs and are at high impedance when the output-enable ( $\overline{OE}$ ) input is high.  $\overline{OE}$  does not affect the IR or OR.

The SN74ALS234 is characterized for operation from 0°C to 70°C.

### logic symbol†

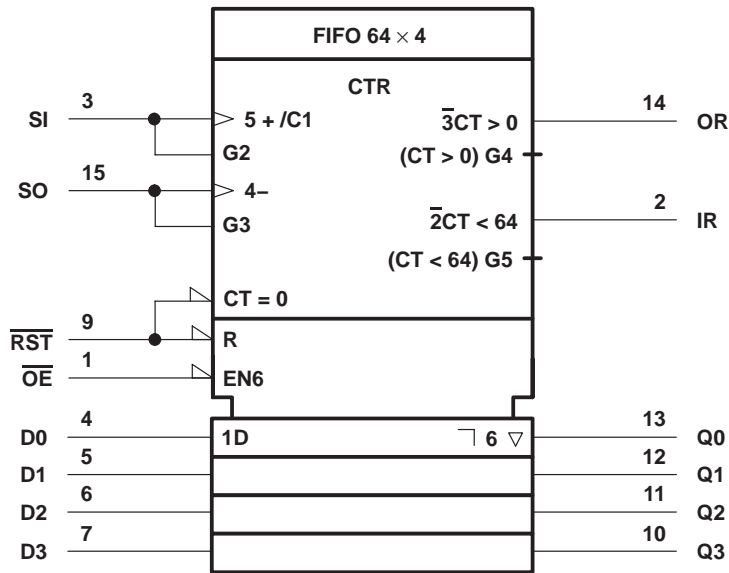

† This symbol is in accordance with ANSI/IEEE Standard 91-1984 and IEC Publication 617-12.

### functional block diagram

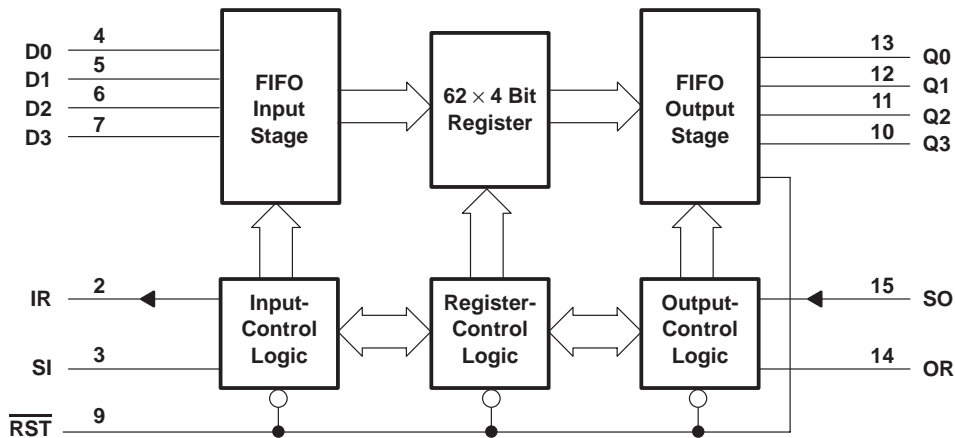

Pin numbers shown are for the DW and N packages.



# SN74ALS234

## 64 × 4 ASYNCHRONOUS FIRST-IN, FIRST-OUT MEMORY

SDAS106B – OCTOBER 1986 – REVISED SEPTEMBER 1993

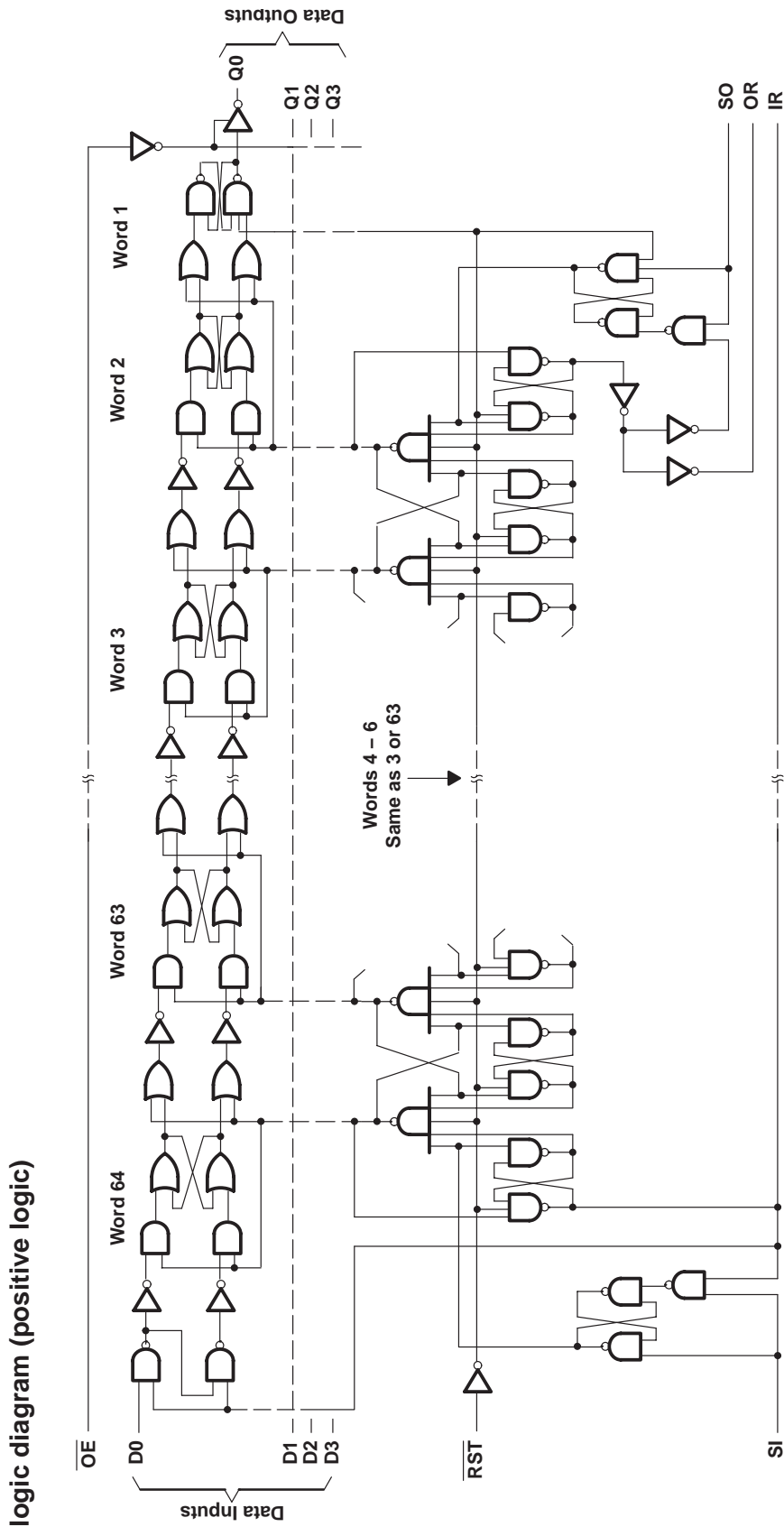

# SN74ALS234

## 64 × 4 ASYNCHRONOUS FIRST-IN, FIRST-OUT MEMORY

SDAS106B – OCTOBER 1986 – REVISED SEPTEMBER 1993

### timing diagram

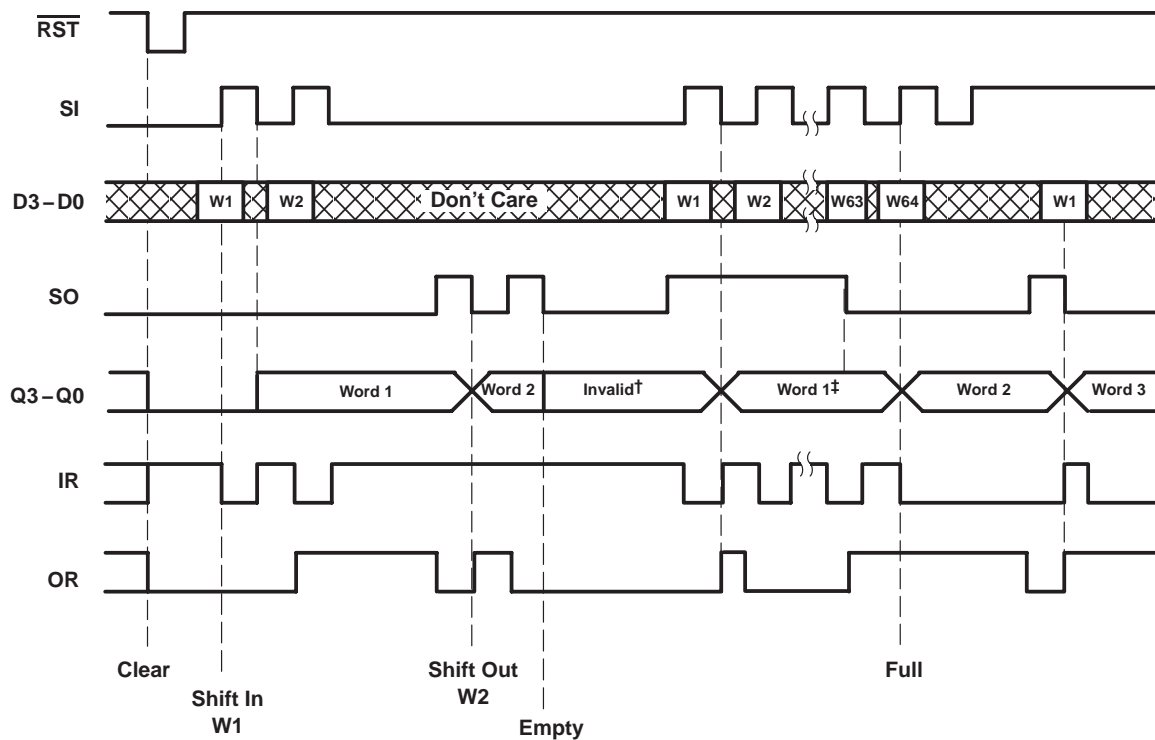

† The last data word shifted out of the FIFO remains at the output until a new word falls through or a  $\overline{\text{RST}}$  pulse clears the FIFO.

‡ While the output data is considered valid only when the OR flag is high, the stored data remains at the outputs. Any additional words written into the FIFO will stack up behind the first word and will not appear at the output until SO is taken low.

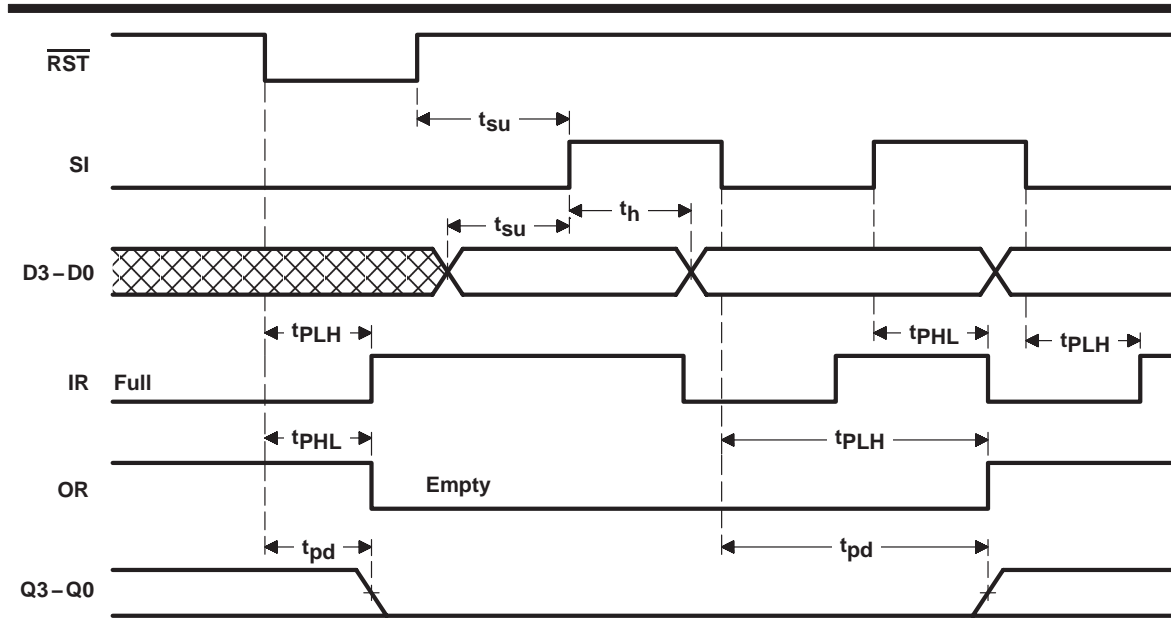

NOTE: SO is low.

**Figure 1. Master Reset and Data-In Waveforms**

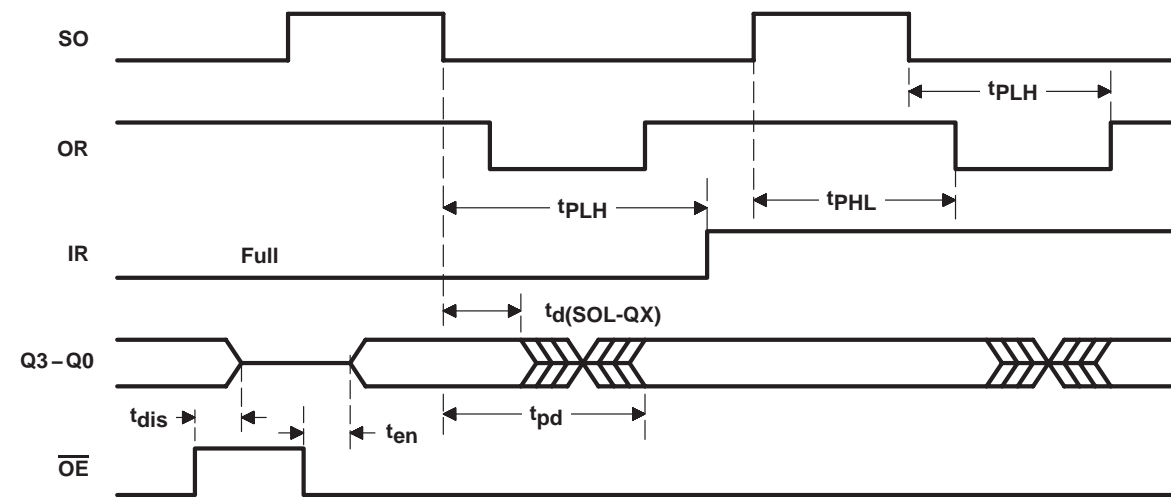

NOTE: SI is low.

**Figure 2. Data-Out Waveforms**

# SN74ALS234

## 64 × 4 ASYNCHRONOUS FIRST-IN, FIRST-OUT MEMORY

SDAS106B – OCTOBER 1986 – REVISED SEPTEMBER 1993

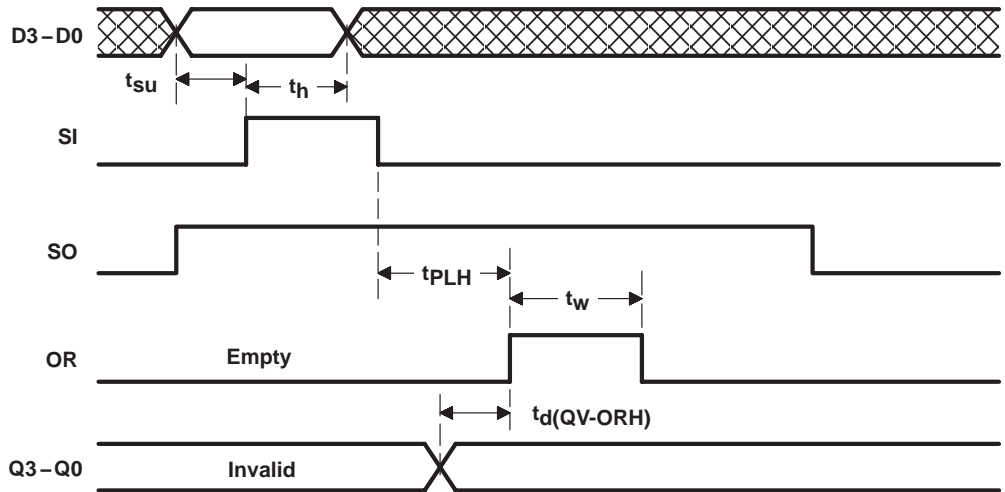

Figure 3. Data Fall-Through Waveforms

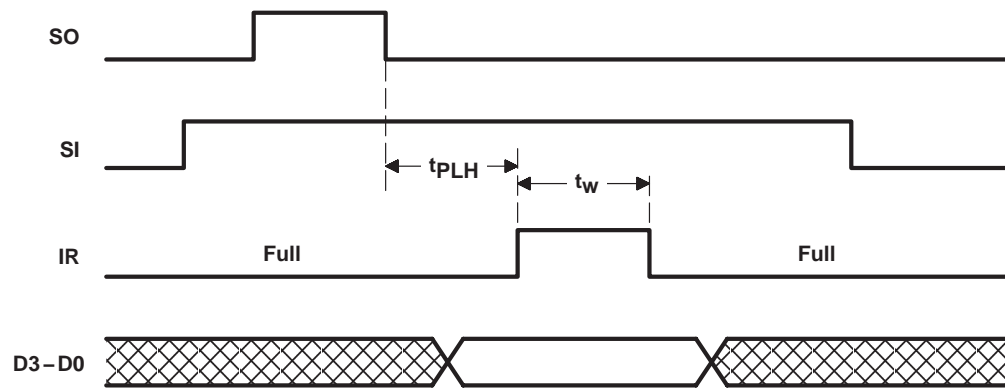

Figure 4. Automatic Data-In Waveforms

### absolute maximum ratings over operating free-air temperature range (unless otherwise noted)†

Supply voltage, $V_{CC}$ (see Note 1)	7 V
Input voltage, $V_I$	7 V
Voltage applied to a disabled 3-state output	5.5 V
Operating free-air temperature range, $T_A$	0°C to 70°C
Storage temperature range	-65°C to 150°C

† Stresses beyond those listed under “absolute maximum ratings” may cause permanent damage to the device. These are stress ratings only, and functional operation of the device at these or any other conditions beyond those indicated under “recommended operating conditions” is not implied. Exposure to absolute-maximum-rated conditions for extended periods may affect device reliability.

NOTE 1: All voltage values are with respect to GND.

# SN74ALS234

## 64 × 4 ASYNCHRONOUS FIRST-IN, FIRST-OUT MEMORY

SDAS106B – OCTOBER 1986 – REVISED SEPTEMBER 1993

### recommended operating conditions

		MIN	NOM	MAX	UNIT	
V <sub>CC</sub>	Supply voltage	4.5	5	5.5	V	
V <sub>IH</sub>	High-level input voltage	2			V	
V <sub>IL</sub>	Low-level input voltage			0.8	V	
I <sub>OH</sub>	High-level output current	Q outputs		-2.6	mA	
		IR and OR		-0.4		
I <sub>OL</sub>	Low-level output current	Q outputs		24	mA	
		IR and OR		8		
f <sub>clock</sub>	Clock frequency	SI or SO		0	30	MHz
t <sub>w</sub>	Pulse duration	SI or SO	High or low	15	ns	
		RST	Low	15		
t <sub>su</sub>	Setup time before SI↑	Data		0	ns	
		RST	High (inactive)	15		
t <sub>h</sub>	Hold time, data after SI↑			17	ns	
T <sub>A</sub>	Operating free-air temperature			0	70	°C

### electrical characteristics over recommended operating free-air temperature range (unless otherwise noted)

PARAMETER		TEST CONDITIONS		MIN	TYP†	MAX	UNIT
V <sub>IK</sub>		V <sub>CC</sub> = 4.5 V,	I <sub>I</sub> = -18 mA			-1.2	V
V <sub>OH</sub>	Any Q	V <sub>CC</sub> = 4.5 V	I <sub>OH</sub> = -1 mA				V
	IR, OR		I <sub>OH</sub> = -2.6 mA	2.4	3.2		
V <sub>OL</sub>	Any Q	V <sub>CC</sub> = 4.5 V	I <sub>OH</sub> = -0.4 mA	2.7	3.4		V
			I <sub>OL</sub> = 12 mA			0.25	
	I <sub>OL</sub> = 24 mA				0.35	0.5	
	I <sub>OL</sub> = 4 mA				0.25	0.4	
IR, OR	V <sub>CC</sub> = 4.5 V	I <sub>OL</sub> = 8 mA			0.35	0.5	
I <sub>OZH</sub>		V <sub>CC</sub> = 5.5 V,	V <sub>O</sub> = 2.7 V			20	μA
I <sub>OZL</sub>		V <sub>CC</sub> = 5.5 V,	V <sub>O</sub> = 0.4 V			-20	μA
I <sub>I</sub>		V <sub>CC</sub> = 5.5 V,	V <sub>I</sub> = 7 V			0.1	mA
I <sub>IH</sub>		V <sub>CC</sub> = 5.5 V,	V <sub>I</sub> = 2.7 V			20	μA
I <sub>IL</sub>		V <sub>CC</sub> = 5.5 V,	V <sub>I</sub> = 0.4 V			-0.1	mA
I <sub>O‡</sub>		V <sub>CC</sub> = 5.5 V,	V <sub>O</sub> = 2.25 V	-30		-112	mA
I <sub>CC</sub>	V <sub>CC</sub> = 5.5 V	Low			100	145	mA
		High			97	142	
		Disabled			103	148	

† All typical values are at V<sub>CC</sub> = 5 V, T<sub>A</sub> = 25°C.

‡ The output conditions have been chosen to produce a current that closely approximates one half of the true short-circuit output current, I<sub>OS</sub>.



# SN74ALS234

## 64 × 4 ASYNCHRONOUS FIRST-IN, FIRST-OUT MEMORY

SDAS106B – OCTOBER 1986 – REVISED SEPTEMBER 1993

### switching characteristics (see Figure 5)

PARAMETER	FROM (INPUT)	TO (OUTPUT)	V <sub>CC</sub> = 5 V, C <sub>L</sub> = 50 pF, R1 = 500 Ω, R2 = 500 Ω, T <sub>A</sub> = 25°C			V <sub>CC</sub> = 4.5 V to 5.5 V, C <sub>L</sub> = 50 pF, R1 = 500 Ω, R2 = 500 Ω, T <sub>A</sub> = MIN to MAX†		UNIT
			MIN	TYP	MAX	MIN	MAX	
f <sub>max</sub>	SI		35			30		MHz
	SO		35			30		
tw <sup>‡</sup>	IR high		15			8		ns
tw <sup>§</sup>	OR high		19			8		ns
t <sub>d</sub> (QV-ORH)	Q valid before OR↑		6			9		ns
t <sub>d</sub> (SOL-QX)	Q valid after SO↓		13			4		ns
t <sub>pd</sub>	SI↓	Q	600	800	350	1000	ns	
t <sub>PHL</sub>	SI↑	IR	20	26	8	30	ns	
t <sub>PLH</sub>	SI↓		16	21	6	25		
t <sub>PLH</sub> <sup>¶</sup>	SI↓	OR	600	800	350	1000	ns	
t <sub>pd</sub>	SO↓	Q	13	17	4	22	ns	
t <sub>PHL</sub>	SO↑	OR	23	27	7	33	ns	
t <sub>PLH</sub>	SO↓		20	24	6	30		
t <sub>PLH</sub> <sup>¶</sup>	SO↓	IR	600	800	350	1000	ns	
t <sub>PHL</sub>	$\overline{\text{RST}}\downarrow$	OR	22	26	10	34	ns	
t <sub>PLH</sub>		IR	17	21	6	27		
t <sub>PHL</sub>	$\overline{\text{RST}}\downarrow$	Q	14	17	5	19	ns	
t <sub>dis</sub>	$\overline{\text{OE}}\uparrow$	Q	7	13	2	15	ns	
t <sub>en</sub>	$\overline{\text{OE}}\downarrow$	Q	6	12	2	13	ns	

† For conditions shown as MIN or MAX, use the appropriate value specified under recommended operating conditions.

‡ The IR output pulse occurs when the FIFO is full, SI is high, and SO is pulsed (see Figure 4).

§ The OR output pulse occurs when the FIFO is empty, SO is high, and SI is pulsed (see Figure 3).

¶ Data throughput or fall-through times





**PARAMETER MEASUREMENT INFORMATION**

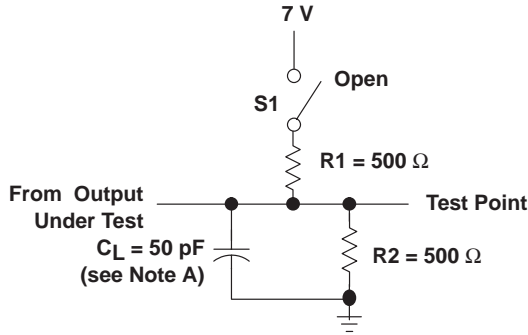

**LOAD CIRCUIT FOR 3-STATE OUTPUTS**

**SWITCH POSITION TABLE**

TEST	S1
t <sub>PLH</sub>	Open
t <sub>PHL</sub>	Open
t <sub>PZH</sub>	Open
t <sub>PZL</sub>	Closed
t <sub>PHZ</sub>	Open
t <sub>PLZ</sub>	Closed

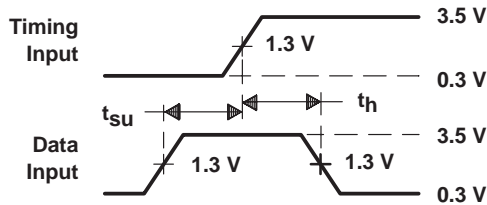

**VOLTAGE WAVEFORMS  
SETUP AND HOLD TIMES**

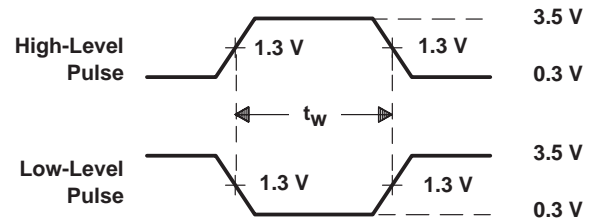

**VOLTAGE WAVEFORMS  
PULSE DURATION**

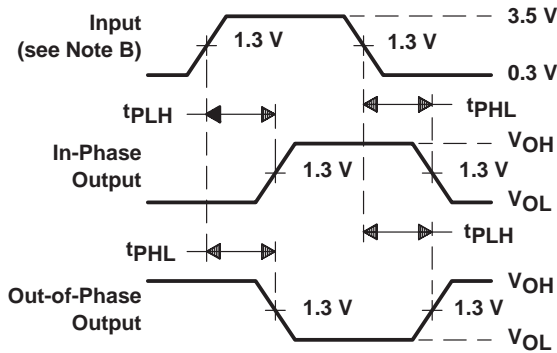

**VOLTAGE WAVEFORMS  
PROPAGATION DELAY TIMES**

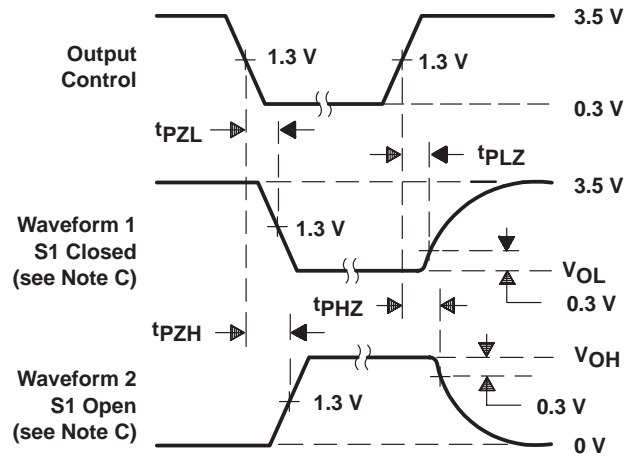

**VOLTAGE WAVEFORMS  
ENABLE AND DISABLE TIMES, 3-STATE OUTPUTS**

- NOTES: A. C<sub>L</sub> includes probe and jig capacitance.  
 B. All input pulses are supplied by generators having the following characteristics: PRR ≤ 1 MHz, Z<sub>O</sub> = 50 Ω, t<sub>r</sub> ≤ 2 ns, t<sub>f</sub> ≤ 2 ns.  
 C. Waveform 1 is for an output with internal conditions such that the output is low except when disabled by the output control. Waveform 2 is for an output with internal conditions such that the output is high except when disabled by the output control.  
 D. The outputs are measured one at a time with one transition per measurement.

**Figure 5. Load Circuit and Voltage Waveforms**

# SN74ALS234

## 64 × 4 ASYNCHRONOUS FIRST-IN, FIRST-OUT MEMORY

SDAS106B – OCTOBER 1986 – REVISED SEPTEMBER 1993

### APPLICATION INFORMATION

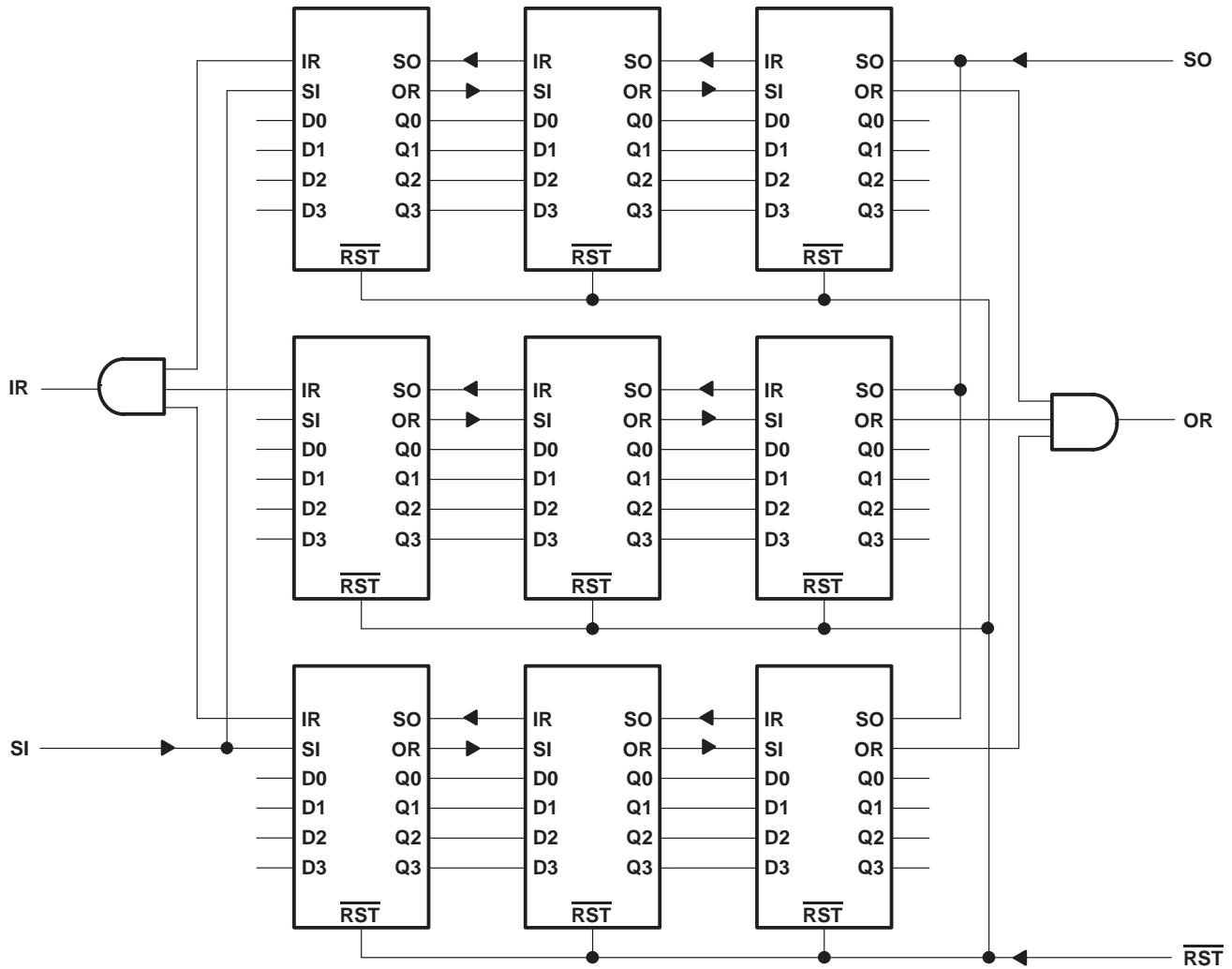

Figure 6. 192-Word by 12-Bit Expansion

## IMPORTANT NOTICE

Texas Instruments Incorporated and its subsidiaries (TI) reserve the right to make corrections, modifications, enhancements, improvements, and other changes to its products and services at any time and to discontinue any product or service without notice. Customers should obtain the latest relevant information before placing orders and should verify that such information is current and complete. All products are sold subject to TI's terms and conditions of sale supplied at the time of order acknowledgment.

TI warrants performance of its hardware products to the specifications applicable at the time of sale in accordance with TI's standard warranty. Testing and other quality control techniques are used to the extent TI deems necessary to support this warranty. Except where mandated by government requirements, testing of all parameters of each product is not necessarily performed.

TI assumes no liability for applications assistance or customer product design. Customers are responsible for their products and applications using TI components. To minimize the risks associated with customer products and applications, customers should provide adequate design and operating safeguards.

TI does not warrant or represent that any license, either express or implied, is granted under any TI patent right, copyright, mask work right, or other TI intellectual property right relating to any combination, machine, or process in which TI products or services are used. Information published by TI regarding third-party products or services does not constitute a license from TI to use such products or services or a warranty or endorsement thereof. Use of such information may require a license from a third party under the patents or other intellectual property of the third party, or a license from TI under the patents or other intellectual property of TI.

Reproduction of TI information in TI data books or data sheets is permissible only if reproduction is without alteration and is accompanied by all associated warranties, conditions, limitations, and notices. Reproduction of this information with alteration is an unfair and deceptive business practice. TI is not responsible or liable for such altered documentation. Information of third parties may be subject to additional restrictions.

Resale of TI products or services with statements different from or beyond the parameters stated by TI for that product or service voids all express and any implied warranties for the associated TI product or service and is an unfair and deceptive business practice. TI is not responsible or liable for any such statements.

TI products are not authorized for use in safety-critical applications (such as life support) where a failure of the TI product would reasonably be expected to cause severe personal injury or death, unless officers of the parties have executed an agreement specifically governing such use. Buyers represent that they have all necessary expertise in the safety and regulatory ramifications of their applications, and acknowledge and agree that they are solely responsible for all legal, regulatory and safety-related requirements concerning their products and any use of TI products in such safety-critical applications, notwithstanding any applications-related information or support that may be provided by TI. Further, Buyers must fully indemnify TI and its representatives against any damages arising out of the use of TI products in such safety-critical applications.

TI products are neither designed nor intended for use in military/aerospace applications or environments unless the TI products are specifically designated by TI as military-grade or "enhanced plastic." Only products designated by TI as military-grade meet military specifications. Buyers acknowledge and agree that any such use of TI products which TI has not designated as military-grade is solely at the Buyer's risk, and that they are solely responsible for compliance with all legal and regulatory requirements in connection with such use.

TI products are neither designed nor intended for use in automotive applications or environments unless the specific TI products are designated by TI as compliant with ISO/TS 16949 requirements. Buyers acknowledge and agree that, if they use any non-designated products in automotive applications, TI will not be responsible for any failure to meet such requirements.

Following are URLs where you can obtain information on other Texas Instruments products and application solutions:

### Products

Amplifiers	<a href="http://amplifier.ti.com">amplifier.ti.com</a>
Data Converters	<a href="http://dataconverter.ti.com">dataconverter.ti.com</a>
DSP	<a href="http://dsp.ti.com">dsp.ti.com</a>
Clocks and Timers	<a href="http://www.ti.com/clocks">www.ti.com/clocks</a>
Interface	<a href="http://interface.ti.com">interface.ti.com</a>
Logic	<a href="http://logic.ti.com">logic.ti.com</a>
Power Mgmt	<a href="http://power.ti.com">power.ti.com</a>
Microcontrollers	<a href="http://microcontroller.ti.com">microcontroller.ti.com</a>
RFID	<a href="http://www.ti-rfid.com">www.ti-rfid.com</a>
RF/IF and ZigBee® Solutions	<a href="http://www.ti.com/lprf">www.ti.com/lprf</a>

### Applications

Audio	<a href="http://www.ti.com/audio">www.ti.com/audio</a>
Automotive	<a href="http://www.ti.com/automotive">www.ti.com/automotive</a>
Broadband	<a href="http://www.ti.com/broadband">www.ti.com/broadband</a>
Digital Control	<a href="http://www.ti.com/digitalcontrol">www.ti.com/digitalcontrol</a>
Medical	<a href="http://www.ti.com/medical">www.ti.com/medical</a>
Military	<a href="http://www.ti.com/military">www.ti.com/military</a>
Optical Networking	<a href="http://www.ti.com/opticalnetwork">www.ti.com/opticalnetwork</a>
Security	<a href="http://www.ti.com/security">www.ti.com/security</a>
Telephony	<a href="http://www.ti.com/telephony">www.ti.com/telephony</a>
Video & Imaging	<a href="http://www.ti.com/video">www.ti.com/video</a>
Wireless	<a href="http://www.ti.com/wireless">www.ti.com/wireless</a>

Mailing Address: Texas Instruments, Post Office Box 655303, Dallas, Texas 75265  
Copyright © 2008, Texas Instruments Incorporated