

# APPROVAL SHEET

**WF25V, WF20V, WF12V, WF08V**

**±1%, ±5%**

Thick Film High Voltage Chip Resistors

Size 2512,2010,1206, 0805

RoHS 2 Compliant with exemption 7C-1

Halogen free



\*Contents in this sheet are subject to change without prior notice

## FEATURE

1. Special material and design for high working voltage require.
2. Compatible with flow and reflow soldering
3. Suitable for lead free soldering.

## APPLICATION

- Power supply
- Automotive industry
- Measurement instrument
- Back light inverter
- Medical or Military equipment

## DESCRIPTION

The resistors are constructed in a high grade ceramic body (aluminum oxide). Internal metal electrodes are added at each end and connected by a resistive paste that is applied to the top surface of the substrate. The composition of the paste is adjusted to give the approximate resistance required and the value is trimmed to nominated value within tolerance which controlled by laser trimming of this resistive layer.

The resistive layer is covered with a protective coat. Finally, the two external end terminations are added. For ease of soldering the outer layer of these end terminations is a Tin (lead free) alloy.

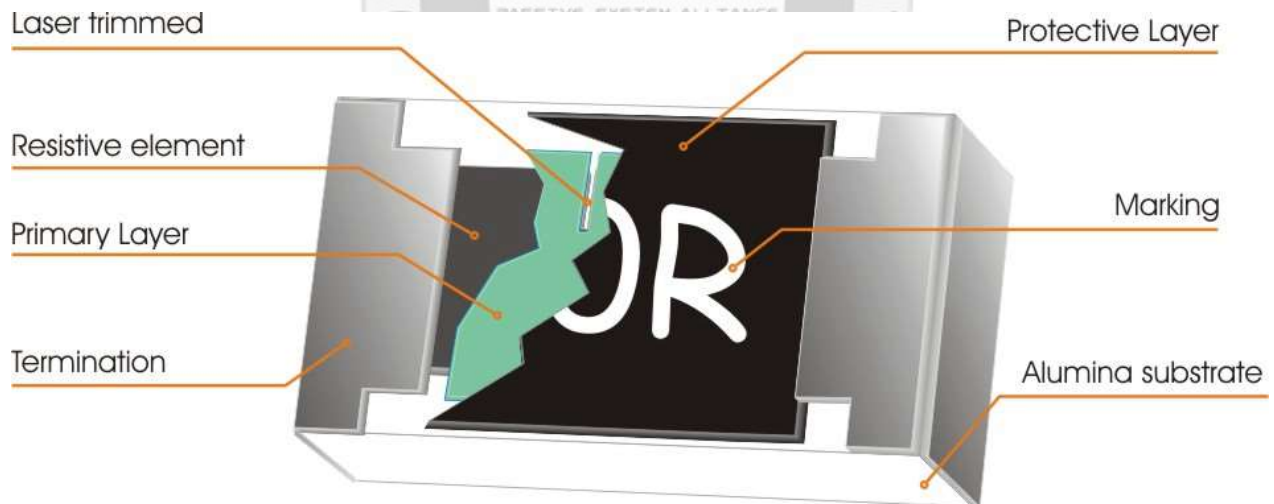

Fig 1. Construction of Chip-R

QUICK REFERENCE DATA

Item	General Specification			
Series No.	WF25V	WF 20V	WF12V	WF08V
Size code	2512(6432 )	2010 ( 5025 )	1206 ( 3216 )	0805 ( 2012 )
Resistance Tolerance	±1%,±5%			
Resistance Range	100 KΩ ~10 MΩ			68 KΩ ~10 MΩ
TCR (ppm/°C)	±100ppm/°C			
Max. Dissipation at T <sub>amb</sub> =70°C	1 W	1/2 W	1/4 W	1/8 W
Max. Operation Voltage (DC or RMS)	3000V	2000V	800V	400V
Max. Overload Voltage (DC or RMS)	4000V	3000V	1600V	800V
Climatic category (IEC 60068)	55/155/56			

Note:

- This is the maximum voltage that may be continuously supplied to the resistor element, see “IEC publication 60115-8”
- Max. Operation Voltage : So called RCWV (Rated Continuous Working Voltage) is determined by

$$RCWV = \sqrt{\text{Rated Power} \times \text{Resistance Value}} \text{ or Max. RCWV listed above, whichever is lower.}$$

MECHANICAL DATA

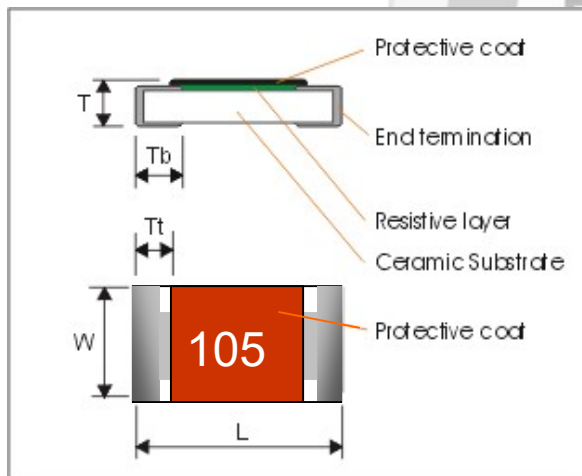

Symbol	WF25V	WF 20V	WF12V	WF08V
L	6.30 ± 0.20	5.00 ± 0.20	3.10 ± 0.15	2.00 ± 0.10
W	3.10 ± 0.20	2.50 ± 0.20	1.60 ± 0.15	1.25 ± 0.10
T	0.60 ± 0.15	0.60 ± 0.10	0.55 ± 0.10	0.50 ± 0.15
Tt	0.60 ± 0.25	0.60 ± 0.25	0.50 ± 0.25	0.40 ± 0.20
Tb	0.90 ± 0.25	0.60 ± 0.25	0.50 ± 0.25	0.40 ± 0.20

R value <100KΩ

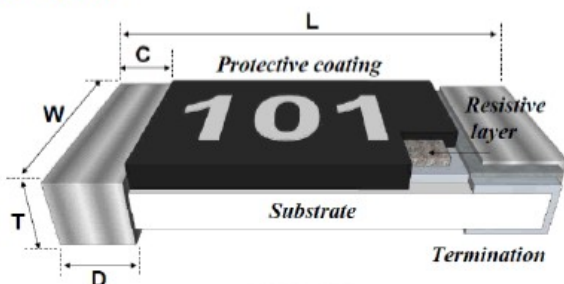

R value ≥100KΩ

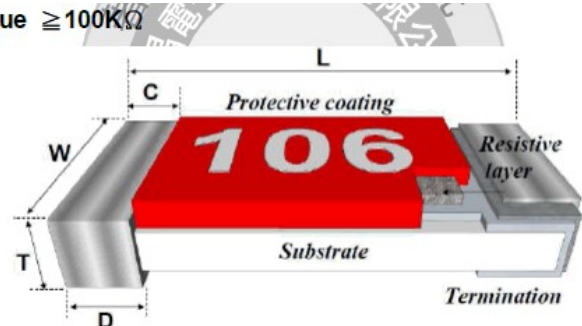

## MARKING

For E24 series, Each resistor is marked with a three-digit code on the protective coating to designate the nominal resistance value for 5%. For E96 & E24 series, Each resistor is marked with a four-digit code on the protective coating to designate the nominal resistance value for 1%.

Example:

105 = 1M $\Omega$



## FUNCTIONAL DESCRIPTION

### Product characterization

Standard values of nominal resistance are taken from the E24/E96 series for resistors with a tolerance of  $\pm 1\%$ ,  $\pm 5\%$ . The values of the E24/E96 series are in accordance with "IEC publication 60063".

### Derating curve

The power that the resistor can dissipate depends on the operating temperature; see Fig.2

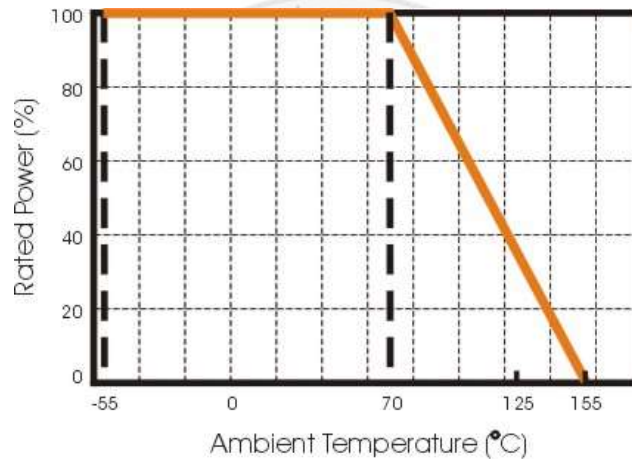

Figure 2 Maximum dissipation in percentage of rated power as a function of the ambient temperature

## MOUNTING

Chip placement can be on ceramic substrates and printed-circuit boards (PCBs).

Electrical connection to the circuit is by individual soldering condition.

The end terminations guarantee a reliable contact.

### SOLDERING CONDITION

The robust construction of chip resistors allows them to be completely immersed in a solder bath of 260°C for 10 seconds. Therefore, it is possible to mount Surface Mount Resistors on one side of a PCB and other discrete components on the reverse (mixed PCBs).

Surface Mount Resistors are tested for solderability at 235°C during 2 seconds. The test condition for no leaching is 260°C for 30 seconds. Typical examples of soldering processes that provide reliable joints without any damage are given in Fig 3.

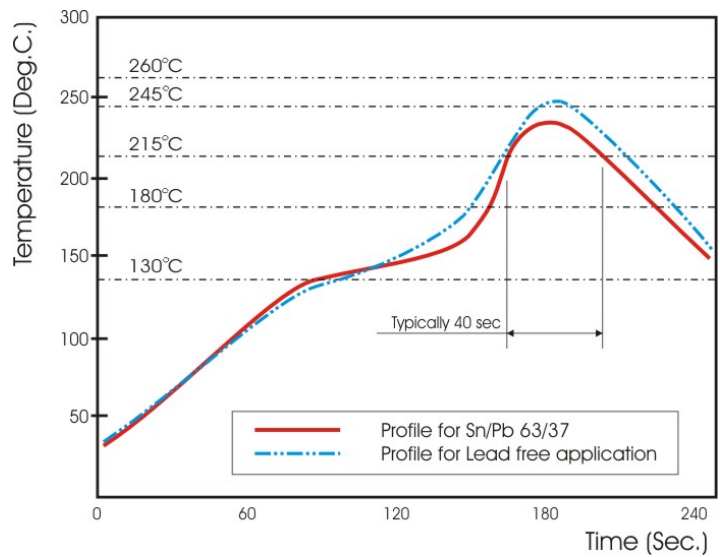

Fig 3. Infrared soldering profile

### CATALOGUE NUMBERS

The resistors have a catalogue number starting with .

WF25	V	105	J	T	L
<b>Size code</b>	<b>Type code</b>	<b>Resistance code</b>	<b>Tolerance</b>	<b>Packaging code</b>	<b>Termination code</b>
WF25 : 2512 WF20 : 2010 WF12 : 1206 WF08 : 0805	V :High Voltage	±5% E24: 2 significant digits followed by no. of zeros and a blank 1 MΩ = 105 ±1%, E24+E96: 3 significant digits followed by no. of zeros 1 MΩ = 1004	J : ±5% F : ±1%	T : 7" inch reel 1206:paper tape, 5kpcs/reel 2010,2512 :plastic tape, 4kpcs/reel	L = Sn base (lead free)

Tape packaging WF12, WF08 : 8mm width paper taping 5,000pcs per reel.

WF25, WF20 : 12mm width plastic taping 4,000pcs per reel.

Marking code : For E24 series , 3 digit marking code for J tol.. E96 & E24 series, 4 digit marking code for F tol.

## TEST AND REQUIREMENTS(JIS C 5201-1 : 1998)

Essentially all tests are carried out according to the schedule of IEC publication 115-8, category **LCT/UCT/56**(rated temperature range : Lower Category Temperature, Upper Category Temperature; damp heat, long term, 56 days). The testing also meets the requirements specified by EIA, EIAJ and JIS.

The tests are carried out in accordance with IEC publication 68, "Recommended basic climatic and mechanical robustness testing procedure for electronic components" and under standard atmospheric conditions according to IEC 60068-1, subclause 5.3. Unless otherwise specified, the following value supplied :

Temperature: 15°C to 35°C.

Relative humidity: 45% to 75%.

Air pressure: 86kPa to 106 kPa (860 mbar to 1060 mbar).

All soldering tests are performed with midly activated flux.

TEST	PROCEDURE	REQUIREMENT
Temperature Coefficient of Resistance(T.C.R) <b>Clause 4.8</b>	Natural resistance change per change in degree centigrade. $\frac{R_2 - R_1}{R_1(t_2 - t_1)} \times 10^6 \text{ (ppm/}^\circ\text{C)}$ R <sub>1</sub> : Resistance at reference temperature R <sub>2</sub> : Resistance at test temperature t <sub>1</sub> : 20°C+5°C-1°C	Refer to "QUICK REFERENCE DATA"
Short time overload (S.T.O.L) <b>Clause 4.13</b>	Permanent resistance change after a 5second application of a voltage 2 times RCWV or the maximum overload voltage specified in the above list, whichever is less.	No visible damage ΔR/R max. ±(1%+0.0001Ω)
Resistance to soldering heat(R.S.H) <b>Clause 4.18</b>	Un-mounted chips completely immersed for 10±1second in a SAC solder bath at 260°C±5°C	no visible damage ΔR/R max. ±(1%+0.0001Ω)
Solderability <b>Clause 4.17</b>	Un-mounted chips completely immersed for 2±0.5second in a SAC solder bath at 235°C±5°C	good tinning (>95% covered) no visible damage
Temperature cycling <b>Clause 4.19</b>	30 minutes at -55°C±3°C, 2~3 minutes at 20°C+5°C-1°C, 30 minutes at +155°C±3°C, 2~3 minutes at 20°C+5°C-1°C, total 5 continuous cycles	no visible damage ΔR/R max. ±(1%+0.0001Ω)
Load life (endurance) <b>Clause 4.25</b>	1000 +48/-0 hours, loaded with RCWV or Vmax in chamber controller 70±2°C, 1.5 hours on and 0.5 hours off	no visible damage ΔR/R max. ±(5%+0.0001Ω)
Load life in Humidity <b>Clause 4.24</b>	1000 +48/-0 hours, loaded with RCWV or Vmax in humidity chamber controller at 40°C±2°C and 90~95% relative humidity, 1.5hours on and 0.5 hours off	no visible damage ΔR/R max. ±(5%+0.0001Ω)



TEST	PROCEDURE	REQUIREMENT
Bending strength <b>Clause 4.33</b>	Resistors mounted on a 90mm glass epoxy resin PCB(FR4), bending : 1206 3 mm, 2512,2010 2mm once for 10 seconds	$\Delta R/R$ max. $\pm(1\%+0.05\Omega)$
Adhesion <b>Clause 4.32</b>	Pressurizing force: 5N, Test time: $10\pm 1$ sec.	No remarkable damage or removal of the terminations
Insulation Resistance <b>Clause 4.6</b>	Apply the maximum overload voltage (DC) for 1minute	$R \geq 10G\Omega$
Dielectric Withstand Voltage <b>Clause 4.7</b>	Apply the maximum overload voltage (AC) for 1 minute	No breakdown or flashover
Voltage Coefficient of Resistance (VCR) (ppm/Volts)	IEC 60115-1, Clause 4.11 Max. test voltage : 500V $V_L$ : 10% RCWV or Max. RCWV $V_H$ : 100% RCWV or Max. RCWV	Standard Type $\leq 1M\Omega$ : $\pm 100$ ppm $> 1M\Omega$ : $\pm 200$ ppm $\geq 10M\Omega$ : $\pm 300$ ppm Low VCR Type $\leq 5.1M\Omega$ : $\pm 50$ ppm

PACKAGING

Paper Tape specifications (unit :mm)

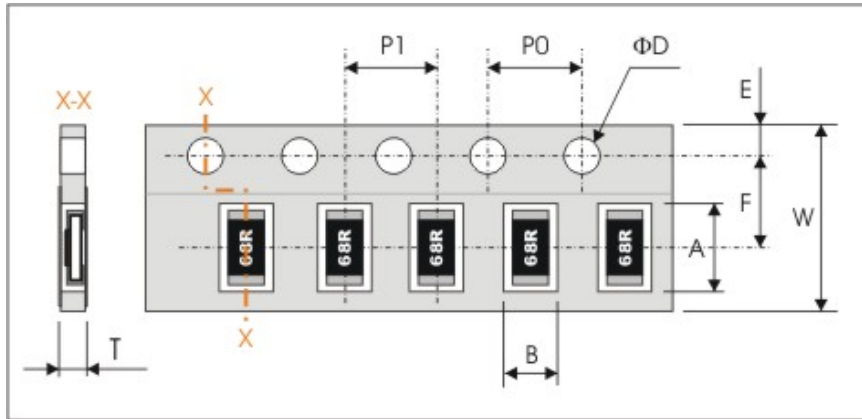

Series No.	A	B	W	F	E
WF25V	6.90±0.20	3.60±0.20	12.00±0.30	5.50±0.10	1.75±0.10
WF20V	5.50±0.20	2.80±0.20			
WF12V	3.60±0.20	2.00±0.20	8.00±0.30	3.50±0.20	1.75±0.10
WF08V	2.40±0.20	1.65±0.20	8.00±0.30	3.50±0.20	1.75±0.10
Series No.	P1	P0	ΦD	T	
WF25V	4.00±0.10	4.00±0.10	Φ1.50 <sup>+0.1</sup> <sub>-0.0</sub>	Max. 1.2	
WF20V					
WF12V				Max. 1.0	
WF08V					

Reel dimensions

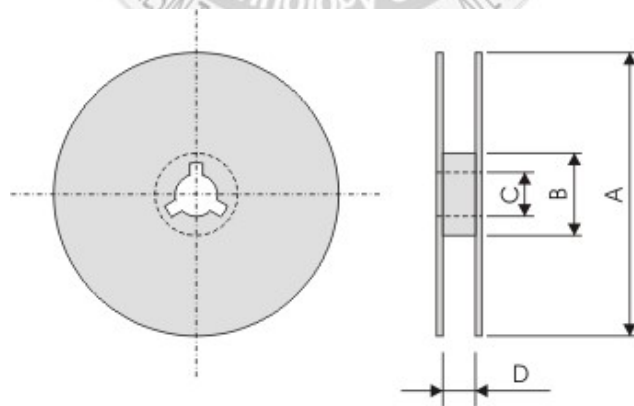

(unit : mm)

Reel / Tape	A	B	C	D
7" reel for 12mm tape	Φ178.0±2.0	Φ60.0±1.0	13.0±0.2	12.4±1.0
7" reel for 8mm tape				9.0±0.5