

## Phase Control IC & Overload Limiatiion — Tacho Applications

### Description

The integrated circuit U211B is designed as a phase-control circuit in bipolar technology with an internal frequency-to-voltage converter. The device includes an internal control amplifier which means it can be used for speed-regulated motor applications.

Amongst others, the device features integrated load limitation, tacho monitoring and soft-start functions, to realize sophisticated motor control systems.

### Features

- Internal Frequency-to-voltage Converter
- Externally controlled Integrated Amplifier
- Overload Limitation with “Fold Back” Characteristic
- Optimized Soft-start Function
- Tacho Monitoring for shorted and Open Loop
- Automatic Retriggering Switchable
- Triggering Pulse Typically 155 mA
- Voltage and Current Synchronization
- Internal Supply-voltage Monitoring
- Temperature Reference Source
- Current Requirement  $\leq 3$  mA

### Block Diagram

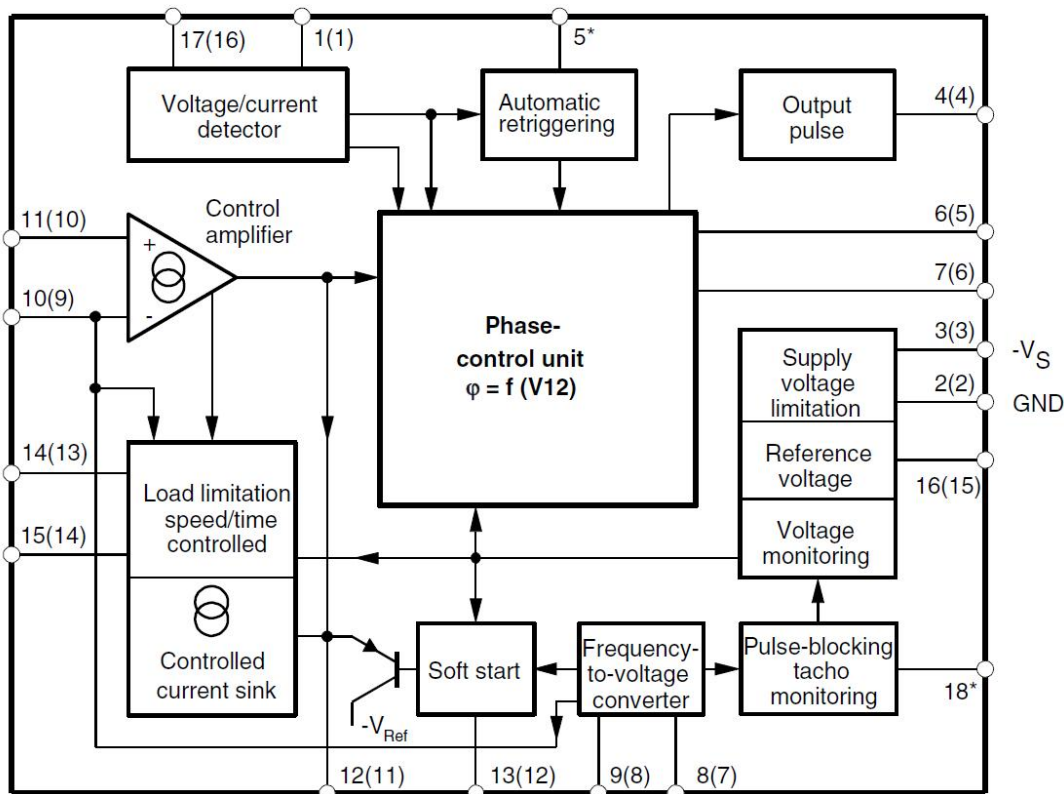

Pin numbers in brackets refer to SO16

\* Pins 5 and 18 connected internally

## Pin Configuration

Pinning DIP18

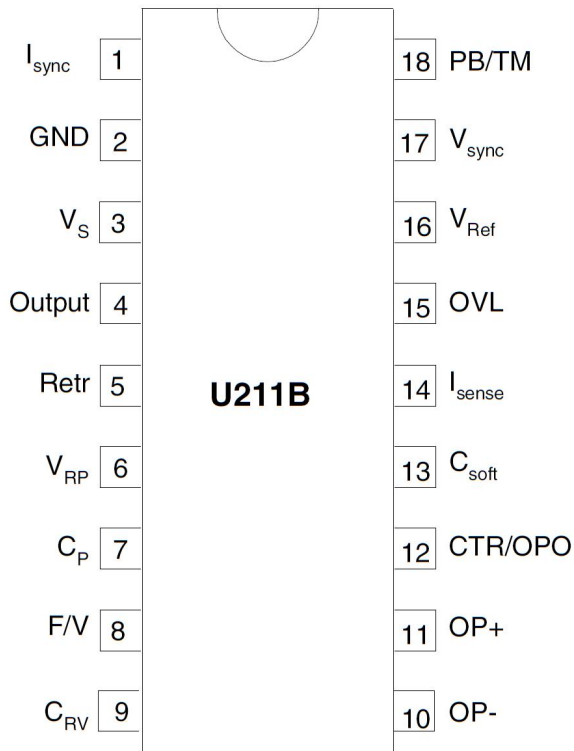

Pin	Symbol	Function
1	I <sub>sync</sub>	Current synchronization
2	GND	Ground
3	V <sub>s</sub>	Supply voltage
4	Output	Trigger pulse output
5	Retr	Retrigger programming
6	V <sub>RP</sub>	Ramp current adjust
7	C <sub>P</sub>	Ramp voltage
8	F/V	Frequency-to-voltage converter
9	C <sub>RV</sub>	Charge pump
10	OP-	OP inverting input
11	OP+	OP non-inverting input
12	CTR/OPO	Control input/OP output
13	C <sub>soft</sub>	Soft start
14	I <sub>sense</sub>	Load-current sensing
15	OVL	Overload adjust
16	V <sub>ref</sub>	Reference voltage
17	V <sub>sync</sub>	Voltage synchronization
18	PB/TM	Pulse blocking/tacho monitoring

## Pinning SOP16

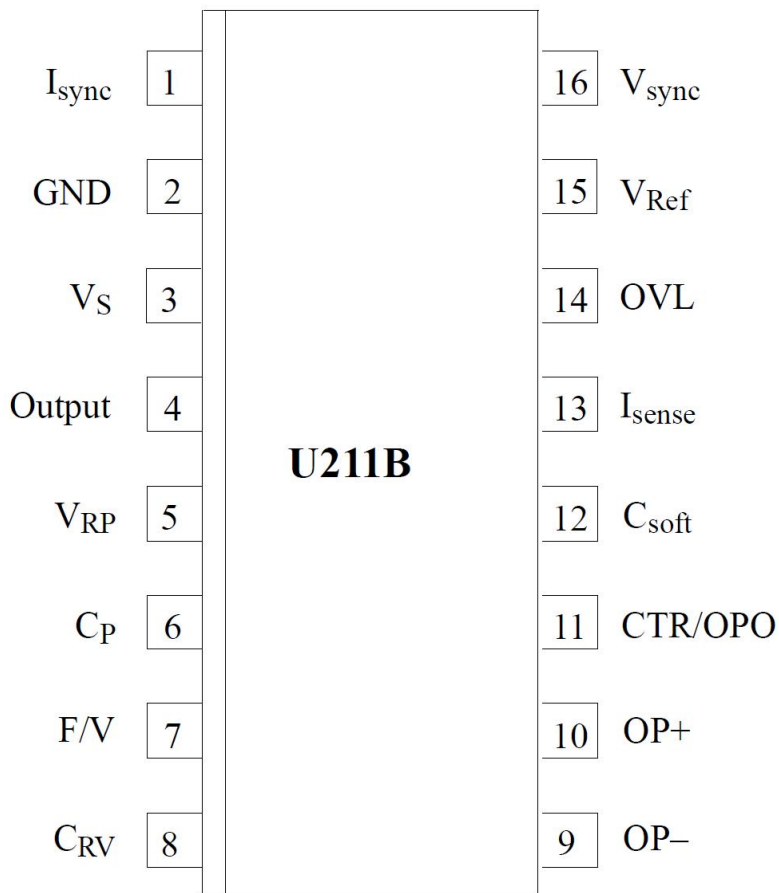

Pin	Symbol	Function
1	I <sub>sync</sub>	Current synchronization
2	GND	Ground
3	V <sub>S</sub>	Supply voltage
4	Output	Trigger pulse output
5	V <sub>RP</sub>	Ramp current adjust
6	C <sub>P</sub>	Ramp voltage
7	F/V	Frequency-to-voltage converter
8	C <sub>RV</sub>	Charge pump
9	OP-	OP inverting input
10	OP+	OP non-inverting input
11	CTR/OPO	Control input/OP output
12	C <sub>soft</sub>	Soft start
13	I <sub>sense</sub>	Load-current sensing
14	OVL	Overload adjust
15	V <sub>ref</sub>	Reference voltage
16	V <sub>sync</sub>	Voltage synchronization

## Absolute Maximum Ratings

Reference point pin 2, unless otherwise specified

Stresses beyond those listed under “Absolute Maximum Ratings” may cause permanent damage to the device. Exposure to absolute maximum rating conditions for extended periods may affect device reliability.

Parameters	Pins	Symbol	Value	Unit
Current requirement	3	$-I_S$	30	mA
$t \leq 10 \mu s$	3	$-i_s$	100	mA
Synchronization current	1	$I_{syncf}$	5	mA
	17	$I_{syncv}$	5	mA
$t < 10 \mu s$	1	$\pm i_I$	35	mA
$t < 10 \mu s$	17	$\pm i_I$	35	mA
<b>f/V Converter</b>				
Input current	8	$I_I$	3	mA
$t < 10 \mu s$	8	$\pm i_I$	13	mA
<b>Load Limiting</b>				
Limiting current,negative half wave	14	$I_I$	5	mA
$t < 10 \mu s$	14	$I_I$	35	mA
Input voltage	14	$\pm V_i$	1	V
	15	$-V_I$	$ V_{I6}  to 0$	V
<b>Phase Control</b>				
Input voltage	12	$-V_I$	0 to 7	V
Input current	12	$\pm I_I$	500	$\mu A$
	6	$-I_I$	1	mA
<b>Soft Start</b>				
Input voltage	13	$-V_I$	$ V_{I6}  to 0$	V
<b>Pulse Output</b>				
Reverse voltage	4	$V_R$	$V_S to 5$	V
<b>Pulse Blocking</b>				
Input voltage	18	$-V_I$	$ V_{I6}  to 0$	V
<b>Amplifier</b>				
Input voltage	11	$V_I$	0 to $V_S$	V
Pin 9 open	10	$-V_I$	$ V_{I6}  to 0$	V
<b>Reference Voltage Source</b>				
Output current	16	$I_o$	7.5	mA
Storage temperature range		$T_{stq}$	-40 to +125	$^{\circ}C$
Junction temperature		$T_i$	125	$^{\circ}C$
Ambient temperature range		$T_{amb}$	-10 to +85	$^{\circ}C$

### Thermal Resistance

Parameters		Symbol	Value	Unit
Junction ambient	DIP18	RthJA	120	K/W
	SOP16 on p.c.	RthJA	180	K/W
	SOP16 on ceramic	RthJA	100	K/W

### Electrical Characteristics

-VS = 13.0 V, Tamb = 25° C, reference point pin 2, unless otherwise specified

Parameters	Tset conditions	Pins	Symbol	Min.	Typ.	Max.	Unit
Supply voltage for mains operation		3	-VS	13.0		VLimit	V
Supply voltage limitation	-IS = 4 mA	3	-VS	14.6		16.6	V
	-IS = 30 mA			14.7		16.8	V
DC current requirement	-VS = 13.0 V	3	IS	1.2	2.5	3.0	mA
Reference voltage source	-IL = 10 uA	16	-VRef	8.6	0.9	9.2	V
	-IL = 5 mA			8.3		9.1	V
Temperature coefficient		16	-TCVRef		0.5		mV/K
<b>Voltage Monitoring</b>							
Turn-on threshold		3	-VSON	11.2	13.0		V
Turn-off threshold		3	-VSOFF	9.9	10.9		V
<b>Phase-control Currents</b>							
Synchronization current		1	±Isyncl	0.35		2.0	mA
		17	±Isyncv				
Voltage limitation	±IL = 5 mA	1,17	±VI	1.4	1.6	1.8	V
<b>Reference Ramp(see Figure 1-1 on page 7)</b>							
Charge current	I7=f(R6) R = 50 kΩ to 1 MΩ	7	I7	1	20		uA
Rφ-reference voltage	α ≥ 180°	6,3	VφRef	1.06	1.13	1.18	V
Temperature coefficient		6	TCVφRef		0.5		mV/K
<b>Pulse Output (see Figure 1-12 on page 9, Pin 4)</b>							
Output pulse current	RGT = 0, VGT = 1.2V		Io	100	155	190	mA
Reverse current			Ior		0.01	3.0	uA
Output pulse width	Cφ = 10 nF		tp		80		us
<b>Amplifier</b>							
Common-mode signal range		10,11	V10,V11	V16		-1	V
Input bias current		11	Io		0.01	1	uA
Input offset voltage		10,11	V10		10		mV

**Electrical Characteristics(continued)**

Parameters	Tset conditions	Pins	Symbol	Min.	Typ.	Max.	Unit
Output current		12	-I <sub>o</sub>	75	110	145	uA
			+I <sub>o</sub>	88	120	165	uA
Short circuit forward,transmittance	I <sub>12</sub> =f(V <sub>10-11</sub> ),(see Figure 1-7 on page 8)	12	Y <sub>f</sub>		1000		uA/V
<b>Pulse Blocking, Tacho Monitoring</b>							
Logic-on		18	-V <sub>TON</sub>	3.7	1.5		V
Logic-off		18	-V <sub>TOFF</sub>		1.25	1.0	V
Input current	V18 = V <sub>TOFF</sub> = 1.25V V18 = V16	18	I <sub>i</sub>		0.3	1	uA
				14.5			uA
Output resistance		18	R <sub>O</sub>	1.5	6	10	kΩ
<b>Frequency-to-voltage Converter</b>							
Input bias current		8	I <sub>IB</sub>		0.6	2	uA
Input voltage limitation (see Figure 1-7 on page 8)	I <sub>I</sub> = -1 mA I <sub>I</sub> = +1 mA	8	-V <sub>I</sub>	660		750	mV
			+V <sub>I</sub>	7.25		8.05	V
Turn-on threshold		8	-V <sub>TON</sub>		100	150	mV
Turn-off threshold		8	-V <sub>TOFF</sub>	20	50		mV
<b>Charge Amplifier</b>							
Discharge current	C5 = 1nF, (see Figure 1-17 on page 10)	9	I <sub>dis</sub>		0.5		mA
Charge transfer voltage		9 to16	V <sub>ch</sub>	6.50	6.70	6.90	V
Charge transfer gain	I10/I9	9,10	G <sub>i</sub>	7.5	8.3	9.0	
Conversion factor	C = 1 nF, R = 100 kΩ (see Figure 1-17 on page 10)		K		5.5		mV/Hz
Output operating range		10to16	V <sub>O</sub>		0-6		V
Linearity					±1		%
<b>Soft Start, f/V Converter Non-active (see Figure 1-2 on page 7 and Figure 1-4 on page 7)</b>							
Starting current	V <sub>13</sub> = V <sub>16</sub> , V <sub>8</sub> = V <sub>2</sub>	13	I <sub>o</sub>	20	45	55	uA
Final current	V <sub>13</sub> = 0.5	13	I <sub>o</sub>	50	85	130	uA
<b>f/V Converter Active (see Figure 1-3 on page 7, Figure 1-5 on page 8 and Figure 1-6 on page 8)</b>							
Starting current	V <sub>13</sub> = V <sub>16</sub>	13	I <sub>o</sub>	2	4	7	uA
Final current	V <sub>13</sub> = 0.5		I <sub>o</sub>	30	55	80	uA
Discharge current	Restart pulse	13	I <sub>o</sub>	0.5	3	10	mA

**Electrical Characteristics(continued)**

Parameters	Tset conditions	Pins	Symbol	Min.	Typ.	Max.	Unit
Automatic Retriggering (see Figure 1-13 on page 9, Pin 5)							
Repetition rate	R5-3 = 0		t <sub>pp</sub>	3	4.5	6	tp
	R5-3 = 15 kΩ		t <sub>pp</sub>		20		tp
Load Limiting (see Figure 1-9 on page 8, Figure 1-10 on page 8 and Figure 1-11 on page 9)							
Operating voltage range		14	V <sub>I</sub>	-1.0		+1.0	V
Offset current	V <sub>10</sub> = V <sub>16</sub>	14	I <sub>o</sub>	5		12	uA
	V <sub>14</sub> = V <sub>2</sub> via 1 kΩ	15-16	I <sub>o</sub>		0.1	1.0	uA
Input current	V <sub>10</sub> = 4.5 V	14	I <sub>i</sub>	60	90	120	uA
Output current	V <sub>14</sub> = 300 mV	15-16	I <sub>o</sub>	110		140	uA
Overload ON		15-16	V <sub>TON</sub>	7.05	7.4	7.7	V

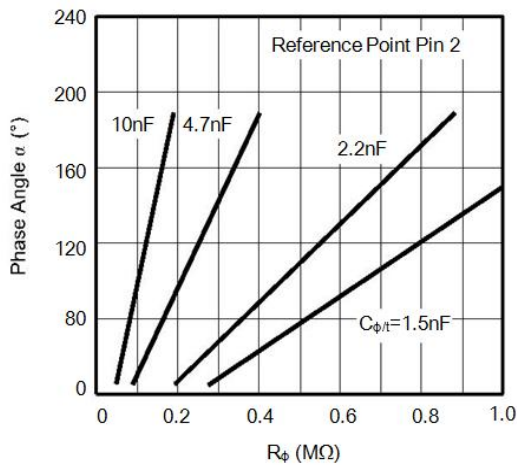

Figure 1-1. Ramp Control

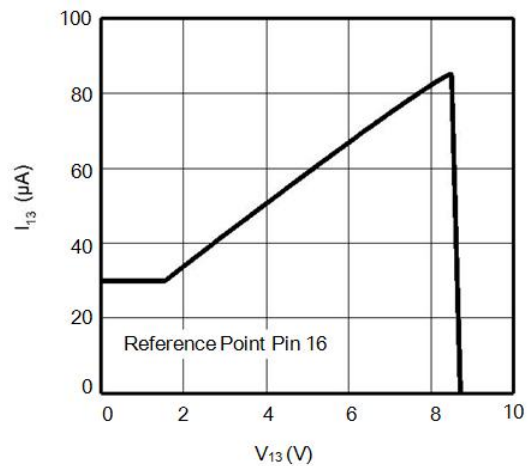

Figure 1-2. Soft-start Charge Current (f/V Converter Non-active)

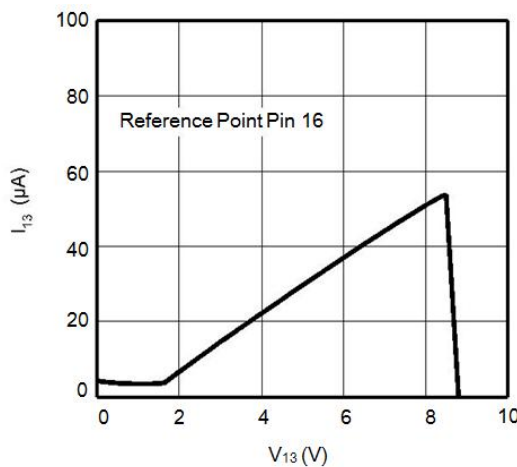

Figure 1-3. Soft-start Charge Current (f/V Converter Active)

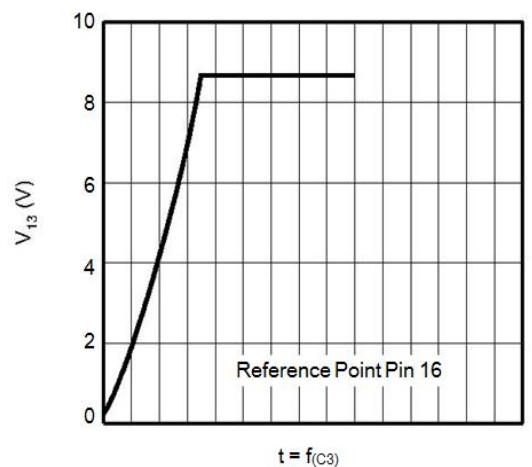

Figure 1-4. Soft-start Voltage (f/V Converter Non-active)

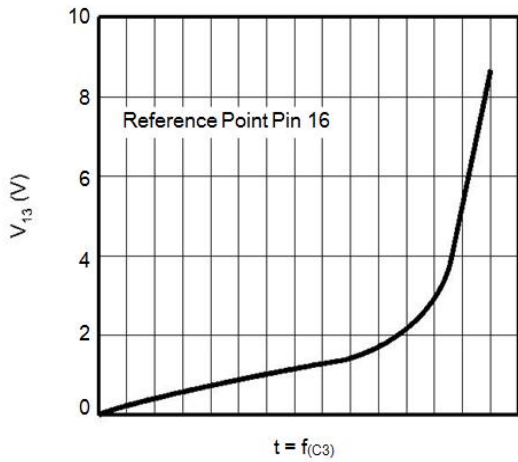

Figure 1-5. Soft-start Voltage (f/V Converter Active)

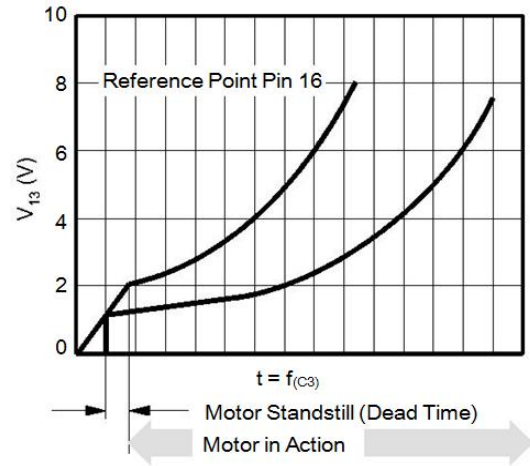

Figure 1-6. Soft-start Function

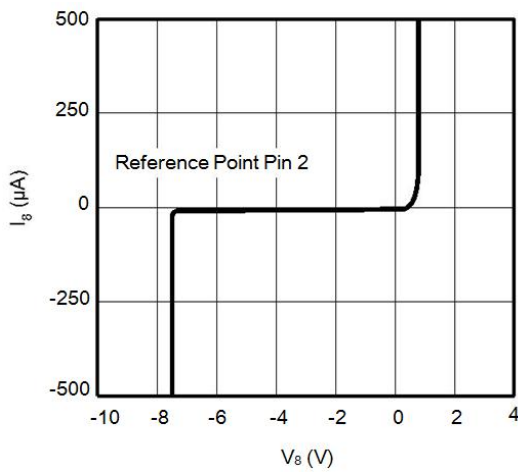

Figure 1-7. f/V Converter Voltage Limitation

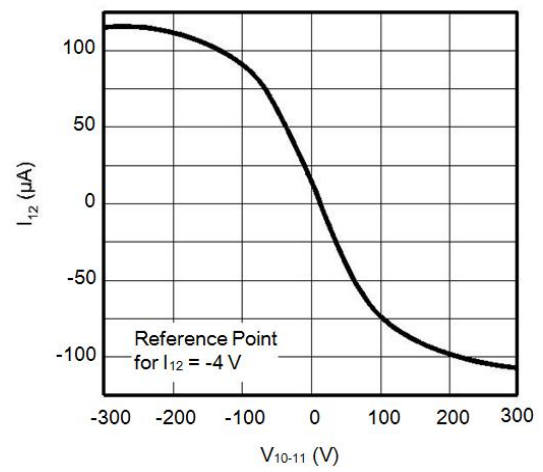

Figure 1-8. Amplifier Output Characteristics

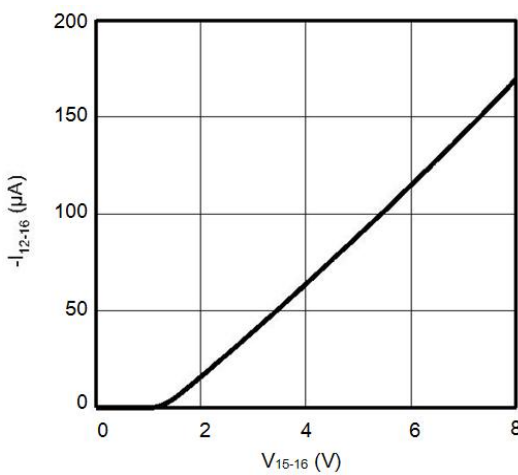

Figure 1-9. Load Limit Control

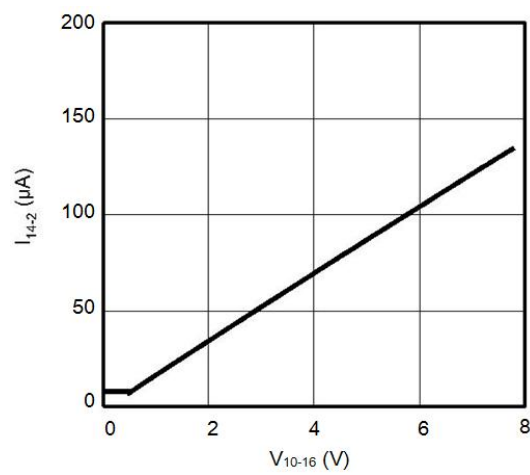

Figure 1-10. Load Limit Control f/V Dependency



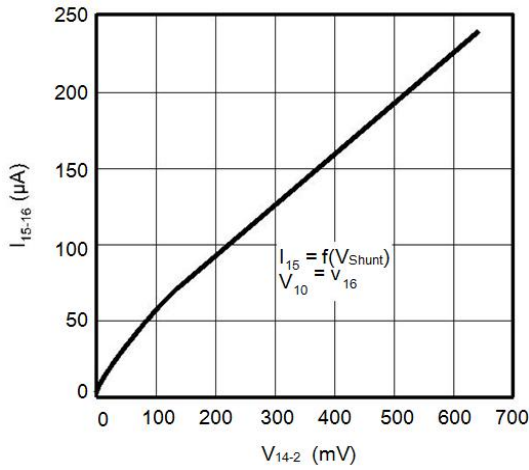

Figure 1-11. Load Current Detection

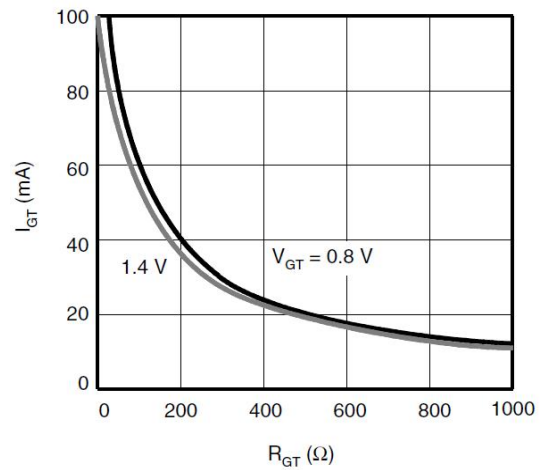

Figure 1-12. Pulse Output

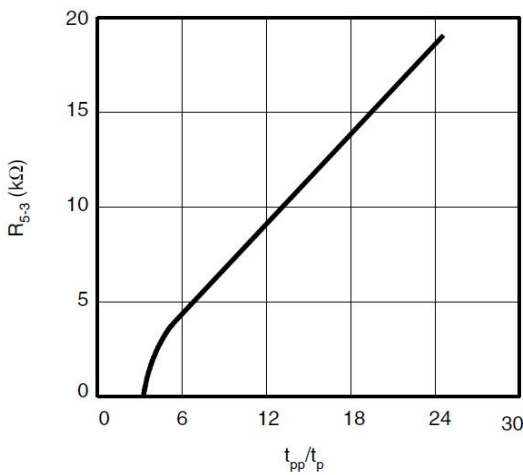

Figure 1-13. Automatic Retriggering Repetition Rate

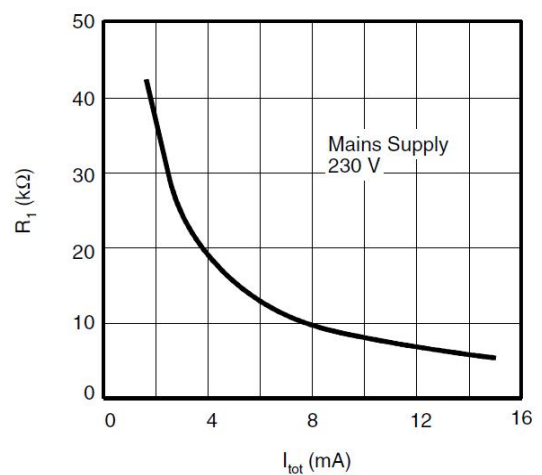

Figure 1-14. Determination of R1

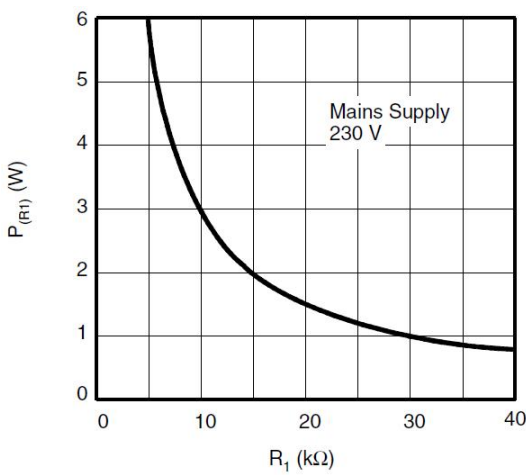

Figure 1-15. Power Dissipation of R1

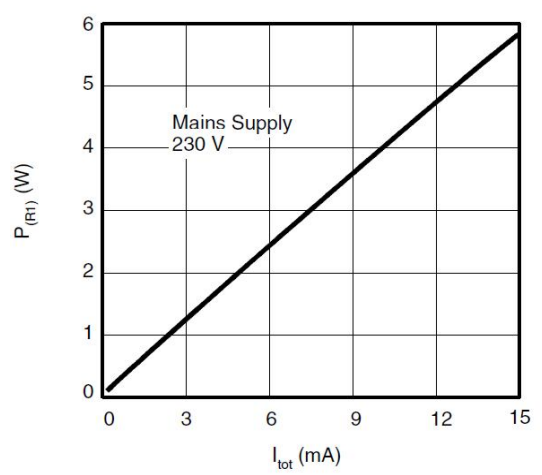

Figure 1-16. Power Dissipation of R1 According to Current Consumption

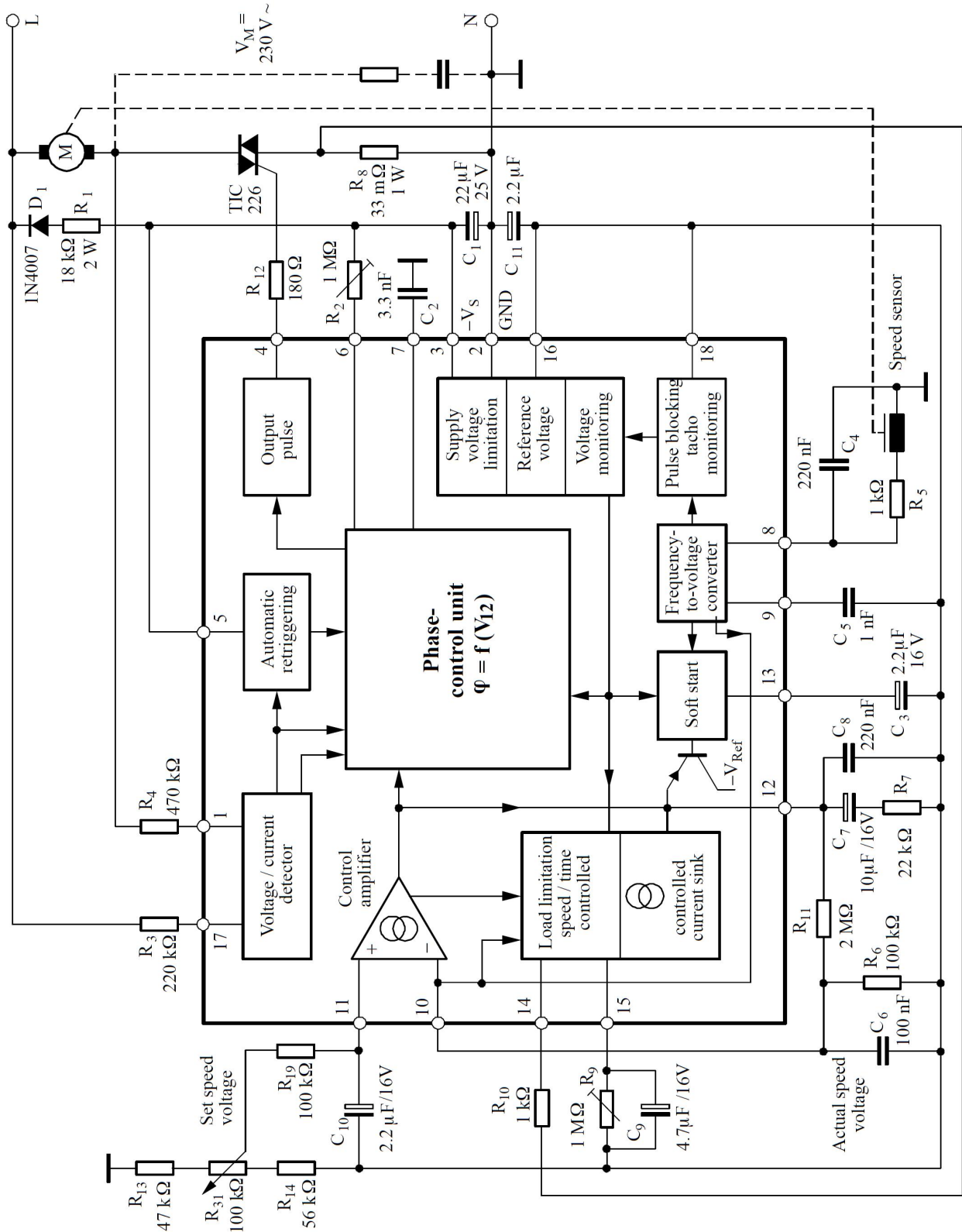

Figure 1-17. Speed Control, Automatic Retriggering, Load Limiting, Soft Start

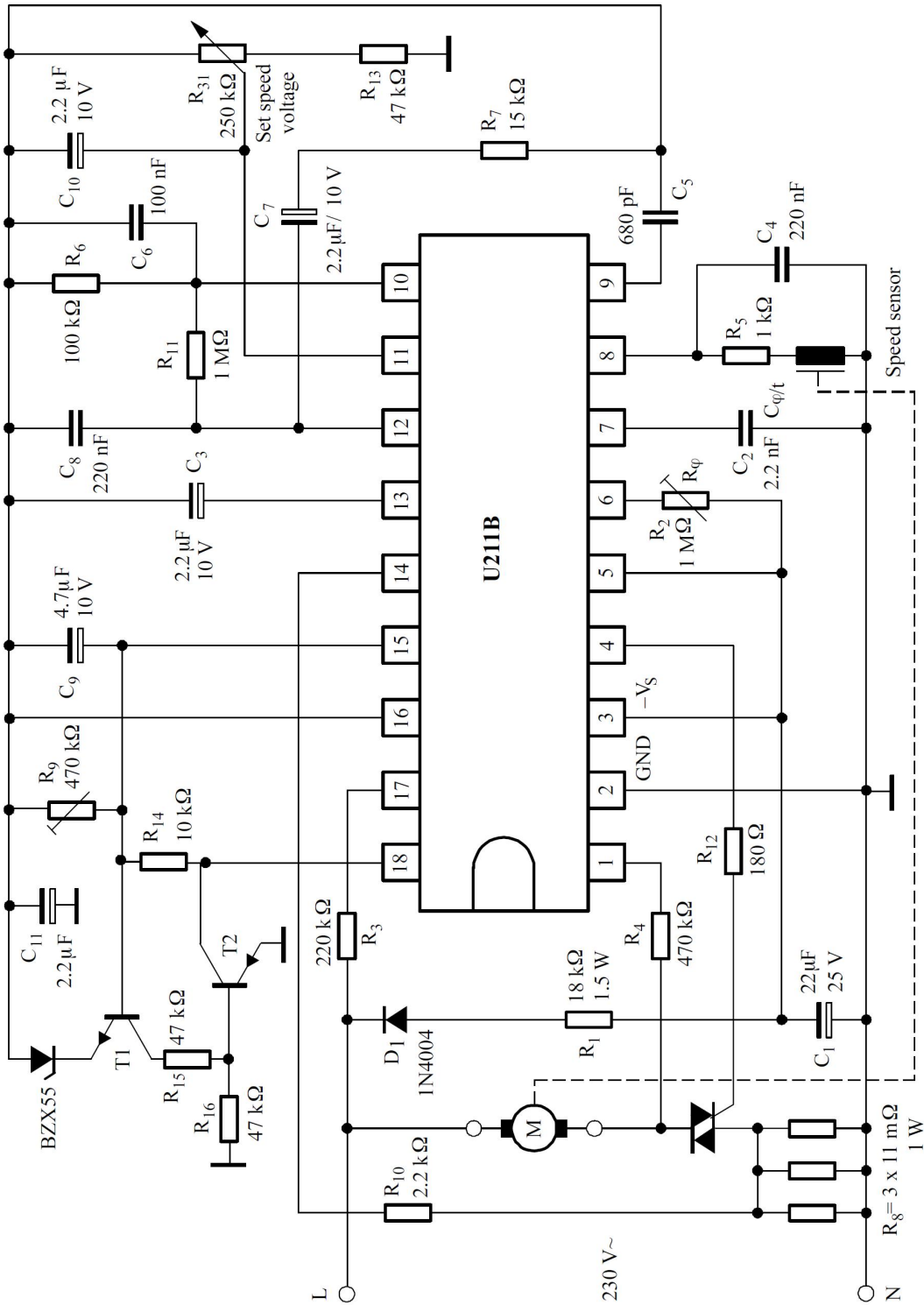

Figure 1-18. Speed Control, Automatic Retriggering, Load Switch-off, Soft Start

The switch-off level at maximum load shows in principle the same speed dependency as the original version (see Figure 1-17 on page 10), but when reaching the maximum load, the motor is switched off completely. This function is effected by the thyristor (formed by T1 and T2 ) which ignites when the voltage at pin 15 reaches typically 7.4 V (reference point pin 16). The circuit is thereby switched to standby mode over the release Pin 18.

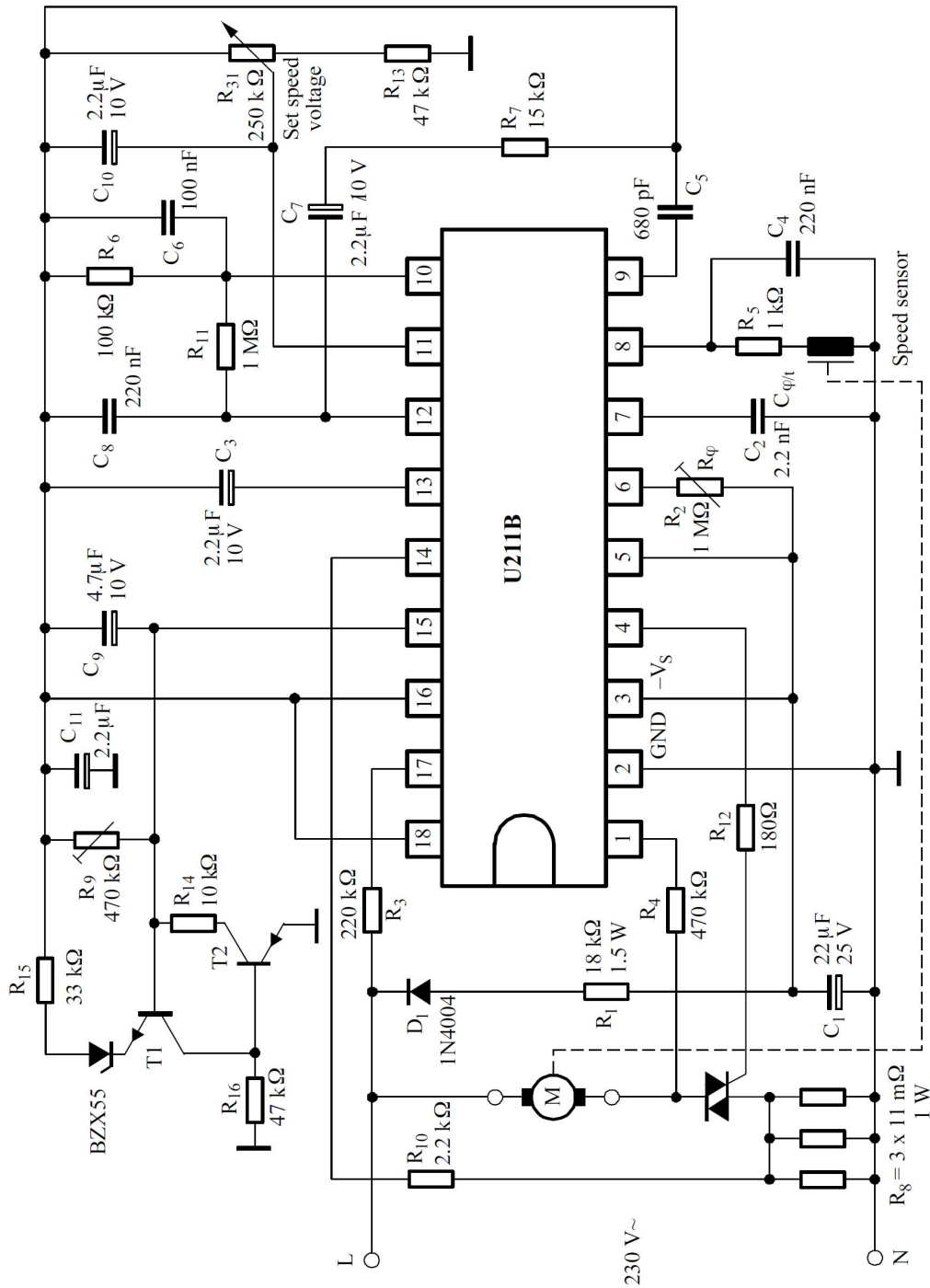

Figure 1-19. Speed Control, Automatic Retriggering, Load Switch-down, Soft Start

The maximum load regulation shows in principle the same speed dependency as the original version (see Figure 1-17 on page 10). When reaching the maximum load, the control unit is turned to  $\alpha_{max}$ , adjustable with R2 . Then, only  $I_o$  flows. This function is effected by the thyristor, formed by T1 and T2 which ignites as soon as the voltage at pin 15 reaches approximately 6.8 V (reference point pin 16). The potential at pin 15 is lifted and kept by R14 over the internal operating threshold whereby the maximum load regulation starts and adjusts the control unit constantly to  $\alpha_{max}$  ( $I_o$ ), inspite of a reduced load current. The motor shows that the circuit is still in operation by producing a buzzing sound.

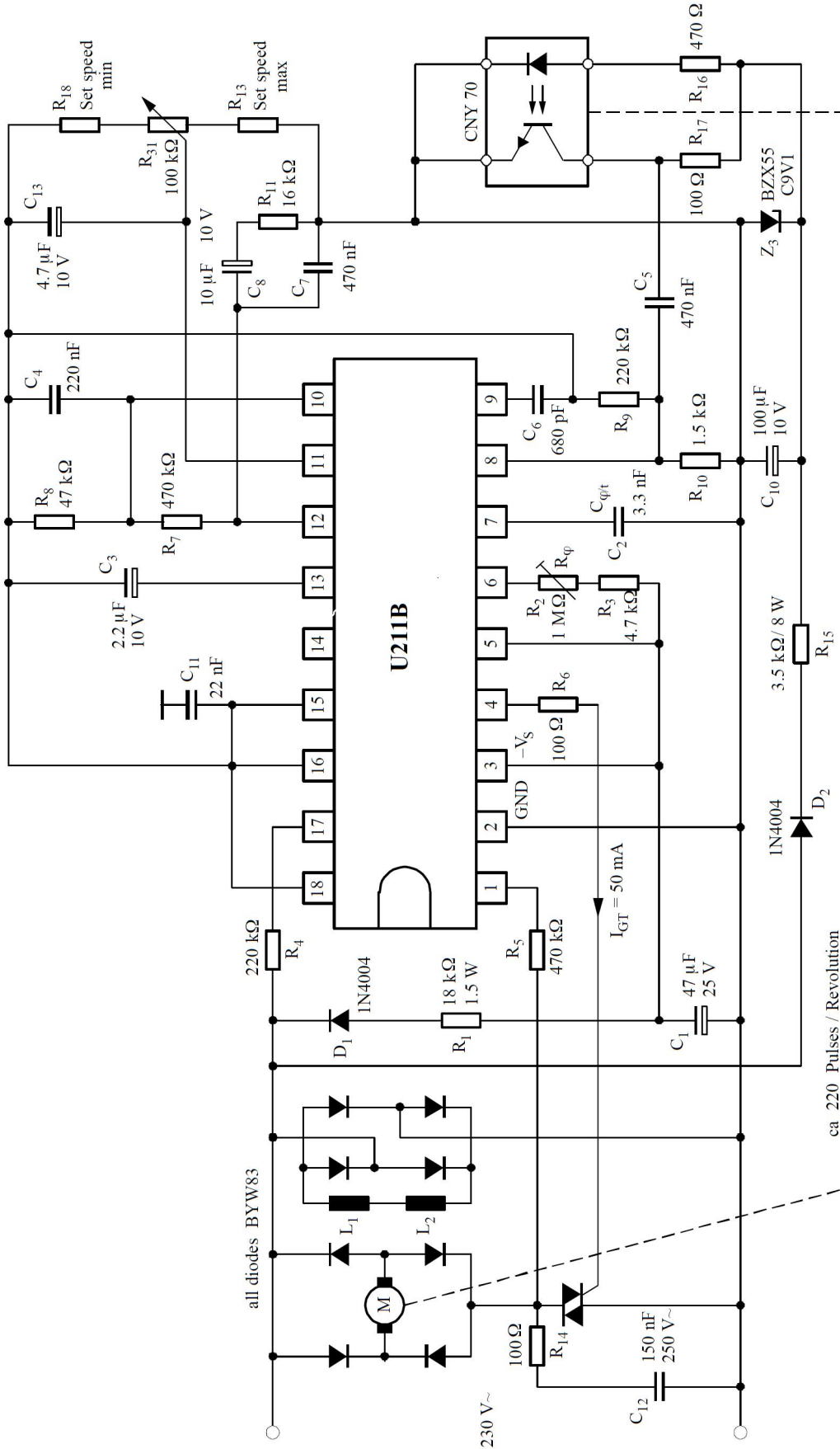

Figure 1-20. Speed Control, Automatic Retriggering, Load Limiting, Soft Start, Tacho Control

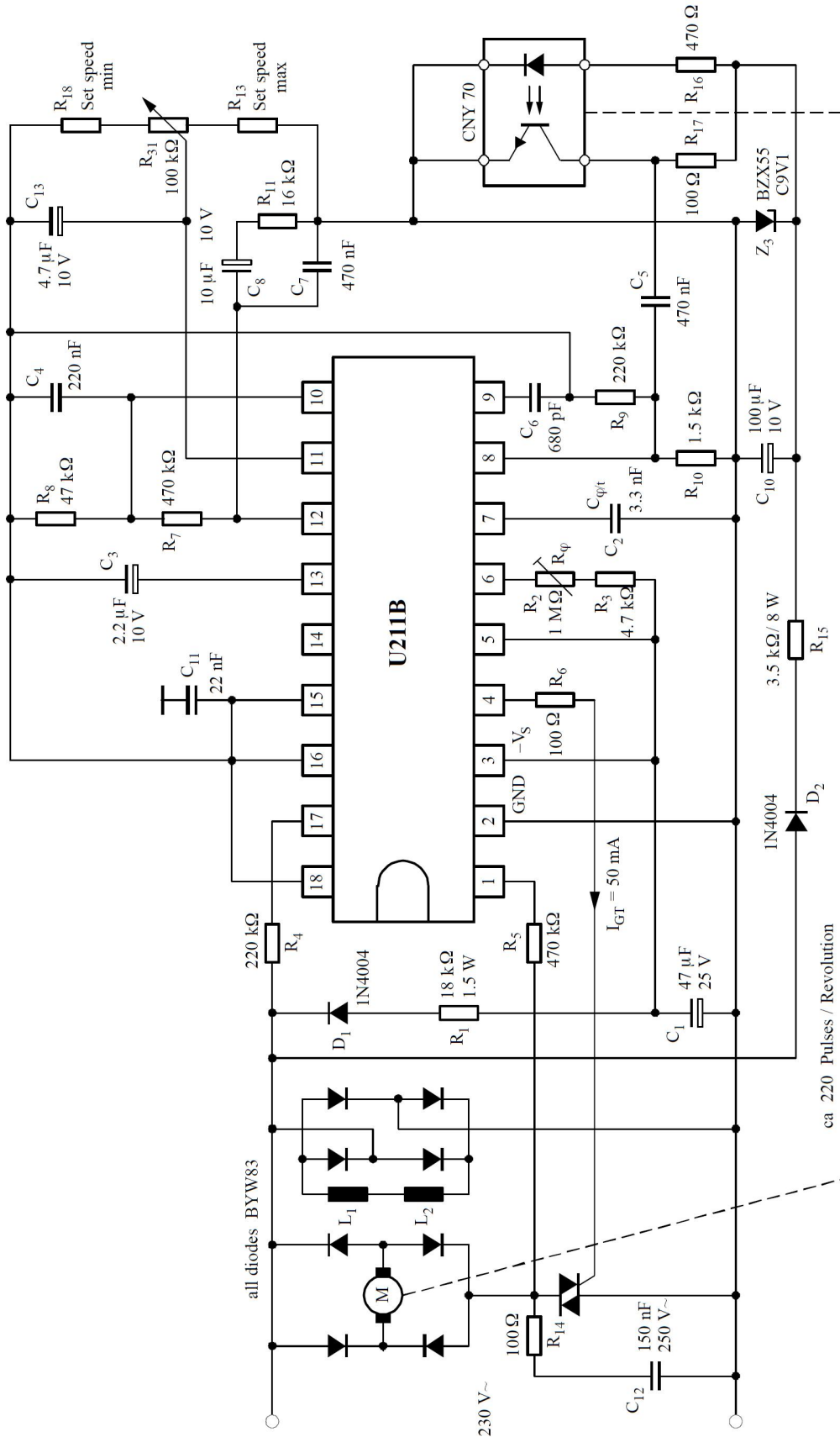

Figure 1-21. Speed Control with Reflective Opto Coupler CNY70 as Emitter

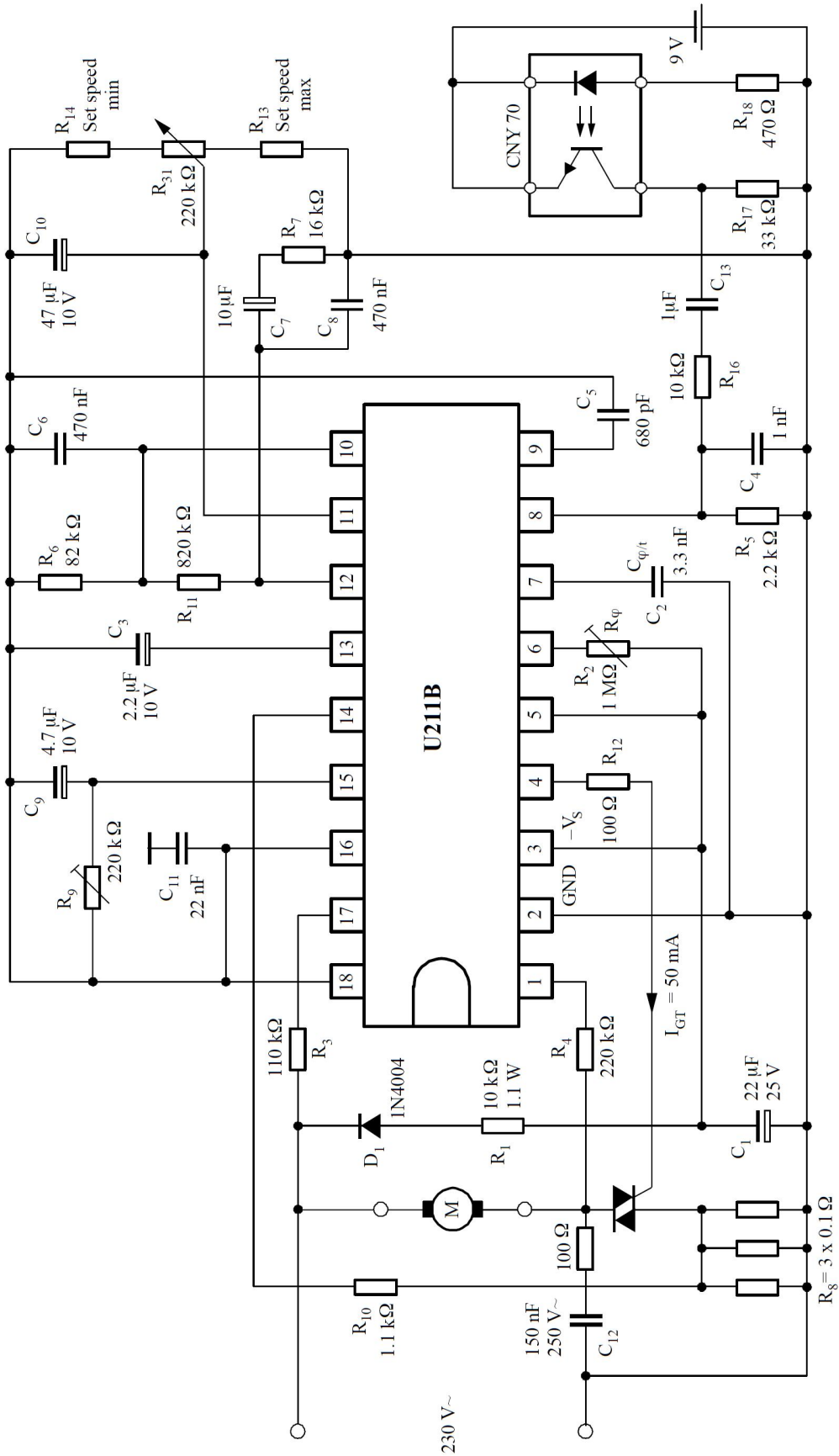

Figure 1-22. Speed Control, Maximum Load Control with Reflective Opto Coupler CNY70 as Emitter

The schematic diagram (see Figure 1-22 on page 15) is designed as a speed control IC based on the reflection-coupled principle with 4 periods per revolution and a maximum speed of 30000 rpm. The separation of the coupler from the rotating aperture should be about approximately 1 mm. In the schematic diagram, the power supply for the coupler was provided externally because of the relatively high current consumption.

Instructions for adjusting:

1. In the initial adjustment of the phase-control circuit, R2 should be adjusted so that when  $R14 = 0$  and R31 are in minimum position, the motor just turns.

2. The speed can now be adjusted as desired by means of R31 between the limits determined by R13 and R14.

3. The switch-off power of the limiting-load control can be set by R9 . The lower R9 , the higher the switch-off power.



## Mains Supply

The U211B is equipped with voltage limiting and can therefore be supplied directly from the mains. The supply voltage between pin 2 (+ pol/\_|\_) and pin 3 builds up across D1 and R1 and is smoothed by C1. The value of the series resistance can be approximated using:

$$R_1 = \frac{V_M - V_S}{2 I_S}$$

Further information regarding the design of the mains supply can be found in the section. The reference voltage source on pin 16 of typically -8.9 V is derived from the supply voltage and is used for regulation.

Operation using an externally stabilized DC voltage is not recommended.

If the supply cannot be taken directly from the mains because the power dissipation in R1 would be too large, the circuit as shown in Figure 2-1 should be used.

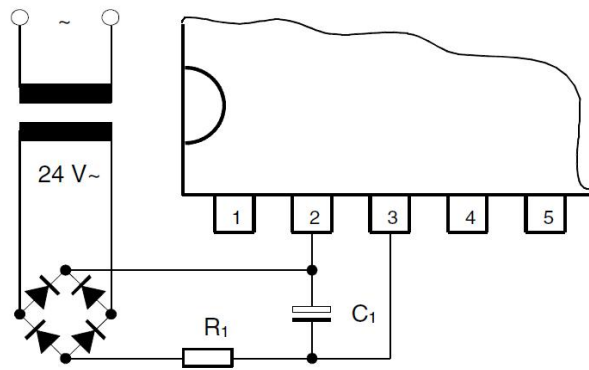

Figure 3-1. Supply Voltage for High Current Requirements

## Phase Control

The phase angle of the trigger pulse is derived by comparing the ramp voltage (which is mains synchronized by the voltage detector) with the set value on the control input pin 12. The slope of the ramp is determined by C2 and its charging current. The charging current can be varied using R2 on pin 6. The maximum phase angle  $\alpha_{max}$  can also be adjusted by using R2.

When the potential on pin 7 reaches the nominal value predetermined at pin 12, a trigger pulse is generated whose width  $t_p$  is determined by the value of C2 (the value of C2 and hence the pulse width can be evaluated by assuming  $8 \mu s/nF$ ). At the same time, a latch is set, so that as long as the automatic retriggering has not been activated, no more pulses can be generated in that half cycle.

The current sensor on pin 1 ensures that, for operations with inductive loads, no pulse will be generated in a new half cycle as long as a current from the previous half cycle is still flowing in the opposite direction to the supply voltage at that instant. This makes sure that “gaps” in the load current are prevented.

The control signal on pin 12 can be in the range of 0 V to -7 V (reference point pin 2).

If  $V_{12} = -7$  V, the phase angle is at maximum ( $\alpha_{max}$ ), i.e., the current flow angle, is at minimum.

The phase angle is minimum ( $\alpha_{min}$ ) when  $V_{12} = V_2$ .

## Voltage Monitoring

As the voltage is built up, uncontrolled output pulses are avoided by internal voltage surveillance. At the same time, all latches in the circuit (phase control, load limit regulation, soft start) are reset and the soft-start capacitor is short circuited. Used with a switching hysteresis of 300 mV, this system guarantees defined start-up behavior each time the supply voltage is switched on or after short interruptions of the mains supply.

## Soft Start

As soon as the supply voltage builds up ( $t_1$ ), the integrated soft start is initiated. Figure 3-1 shows the behavior of the voltage across the soft-start capacitor, which is identical with the voltage on the phase-control input on pin 12. This behavior guarantees a gentle start-up for the motor and automatically ensures the optimum run-up time.

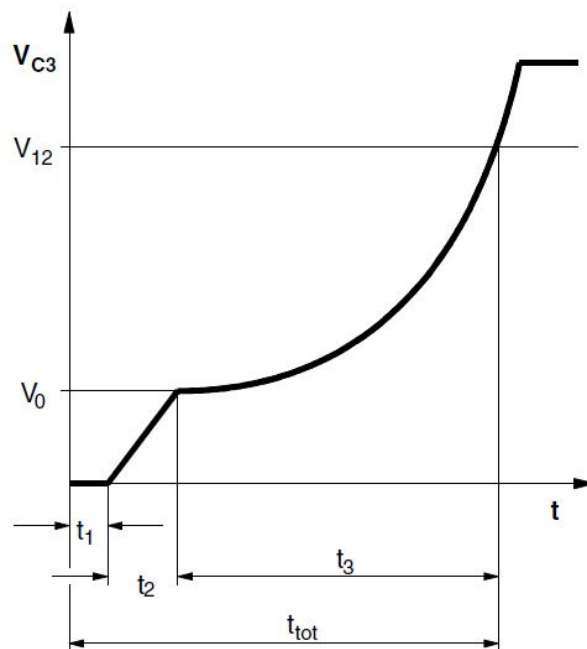

- $t_1$  = Build-up of supply voltage
- $t_2$  = Charging of  $C_3$  to starting voltage
- $t_1 + t_2$  = Dead time
- $t_3$  = Run-up time
- $t_{tot}$  = Total start-up time to required speed

Figure 3-1. Soft Start

$C_3$  is first charged up to the starting voltage  $V_0$  with a current of typically  $45 \mu\text{A}$  ( $t_2$ ). By reducing the charging current to approximately  $4 \mu\text{A}$ , the slope of the charging function is also substantially reduced, so that the rotational speed of the motor only slowly increases. The charging current then increases as the voltage across  $C_3$  increases, resulting in a progressively rising charging function which accelerates the motor more and more with increasing rotational speed. The charging function determines the acceleration up to the set point. The charging current can have a maximum value of  $55 \mu\text{A}$ .

## Frequency-to-voltage Converter

The internal frequency-to-voltage converter (f/V converter) generates a DC signal on pin 10 which is proportional to the rotational speed, using an AC signal from a tacho generator or a light beam whose frequency is in turn dependent on the rotational speed. The high-impedance input pin 8 compares the tacho voltage to a switch-on threshold of typically -100 mV. The switch-off threshold is -50mV. The hysteresis guarantees very reliable operation even when relatively simple tacho generators are used.

The tacho frequency is given by:

$$f = \frac{n}{60} \times p \text{ (Hz)}$$

where: n= Revolutions per minute

p= Number of pulses per revolution

The converter is based on the charge pumping principle. With each negative half-wave of the input signal, a quantity of charge determined by C5 is internally amplified and then integrated by C6 at the converter output on pin 10. The conversion constant is determined by C5 , its charge transfer voltage of V , R (pin 10) and the internally adjusted charge transfer gain.

$$G_i \left[ \frac{I_{10}}{I_g} \right] = 8.3$$

$$k = G \times C \times R \times V_{ch}$$

The analog output voltage is given by:  $V_O = k \times f$

The values of C5 and C6 must be such that for the highest possible input frequency, the maximum output voltage  $V_o$  does not exceed 6 V. While C5 is charging up, the  $R_i$  on pin 9 is approximately 6.7 k $\Omega$ . To obtain good linearity of the f/V converter, the time constant resulting from  $R_i$  and C5 should be considerably less (1/5) than the time span of the negative half-cycle for the highest possible input frequency. The amount of remaining ripple on the output voltage on pin 10 is dependent on C , C and the internal charge amplification.

$$\Delta V_O = \frac{G_i \times V_{ch} \times C_5}{C_6}$$

The ripple  $\Delta V_o$  can be reduced by using larger values of C6 . However, the increasing speed will then also be reduced.

The value of this capacitor should be chosen to fit the particular control loop where it is going to be used.

## Pulse Blocking

The output of pulses can be blocked by using pin 18 (standby operation) and the system reset via the voltage monitor if  $V_{18} \geq -1.25$  V. After cycling through the switching point hysteresis, the output is released when  $V_{18} \leq -1.5$  V, followed by a soft start such as after turn-on.

Monitoring of the rotation can be carried out by connecting an RC network to pin 18. In the event

of a short or open circuit, the triac triggering pulses are cut off by the time delay which is determined by R and C. The capacitor C is discharged via an internal resistance  $R_i = 2\text{ k}\Omega$  with each charge transfer process of the f/V converter. If there are no more charge transfer processes, C is charged up via R until the switch-off threshold is exceeded and the triac triggering pulses are cut off. For operation without trigger pulse blocking or monitoring of the rotation, pin 18 and pin 16 must be connected together.

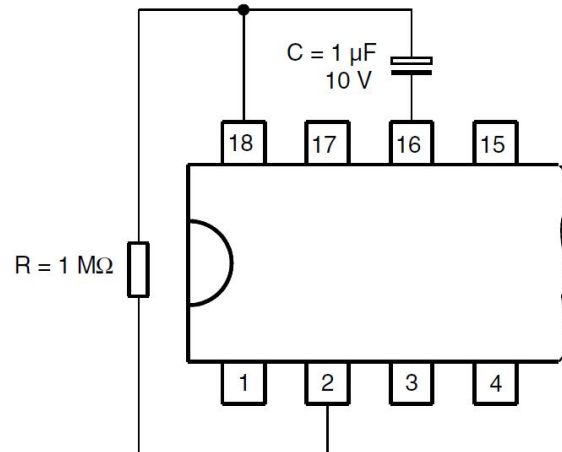

Figure 4-1. Operation Delay

### Control Amplifier

The integrated control amplifier (see Figure 1-17 on page 10) with differential input compares the set value (pin 11) with the instantaneous value on pin 10, and generates a regulating voltage on the output pin 12 (together with the external circuitry on pin 12). This pin always tries to keep the actual voltage at the value of the set voltages. The amplifier has a transmittance of typically  $1000\ \mu\text{A/V}$  and a bipolar current source output on pin 12 which operates with typically  $\pm 110\ \mu\text{A}$ . The amplification and frequency response are determined by R7, C7, C8 and R11 (can be left out). For open-loop operation, C4, C5, R6, R7, C7, C8 and R11 can be omitted. Pin 10 should be connected with pin 12 and pin 8 with pin 2. The phase angle of the triggering pulse can be adjusted by using the voltage on pin 11. An internal limitation circuit prevents the voltage on pin 12 from becoming more negative than  $V_{16} + 1\text{ V}$ .

### Load Limitation

The load limitation, with standard circuitry, provides full protection against overloading of the motor. The function of load limiting takes account of the fact that motors operating at higher speeds can safely withstand larger power dissipations than at lower speeds due to the increased action of the cooling fan. Similarly, considerations have been made for short-term overloads for the motor which are, in practice, often required. These behaviors are not damaging and can be tolerated.

In each positive half-cycle, the circuit measures, via R10, the load current on pin 14 as a potential drop across R8 and produces a current proportional to the voltage on pin 14. This current is

available on pin 15 and is integrated by C9. If, following high-current amplitudes or a large phase angle for current flow, the voltage on C9 exceeds an internally set threshold of approximately 7.3 V (reference voltage pin 16), a latch is set and load limiting is turned on. A current source (sink) controlled by the control voltage on pin 15 now draws current from pin 12 and lowers the control voltage on pin 12 so that the phase angle  $\alpha$  is increased to  $\alpha_{\max}$

The simultaneous reduction of the phase angle during which current flows causes firstly a reduction of the rotational speed of the motor which can even drop to zero if the angular momentum of the motor is excessively large, and secondly a reduction of the potential on C9 which in turn reduces the influence of the current sink on pin 12. The control voltage can then increase again and bring down the phase angle. This cycle of action sets up a “balanced condition” between the “current integral” on pin 15 and the control voltage on pin 12.

Apart from the amplitude of the load current and the time during which current flows, the potential on pin 12 and hence the rotational speed also affects the function of load limiting. A current proportional to the potential on pin 10 gives rise to a voltage drop across R10, via pin 14, so that the current measured on pin 14 is smaller than the actual current through R8.

This means that higher rotational speeds and higher current amplitudes lead to the same current integral. Therefore, at higher speeds, the power dissipation must be greater than that at lower speeds before the internal threshold voltage on pin 15 is exceeded. The effect of speed on the maximum power is determined by the resistor R10 and can therefore be adjusted to suit each individual application.

If, after load limiting has been turned on, the momentum of the load sinks below the “o-momentum” set using R10, V15 will be reduced. V12 can then increase again so that the phase angle is reduced. A smaller phase angle corresponds to a larger momentum of the motor and hence the motor runs up, as long as this is allowed by the load momentum. For an already rotating machine, the effect of rotation on the measured “current integral” ensures that the power dissipation is able to increase with the rotational speed. The result is a current-controlled acceleration run-up which ends in a small peak of acceleration when the set point is reached. The load limiting latch is simultaneously reset. Then the speed of the motor is under control again and is capable of carrying its full load. The above mentioned peak of acceleration depends upon the ripple of actual speed voltage. A large amount of ripple also leads to a large peak of acceleration.

The measuring resistor R8 should have a value which ensures that the amplitude of the voltage across it does not exceed 600 mV.

Package Information

Package DIP18

Dimensions in mm

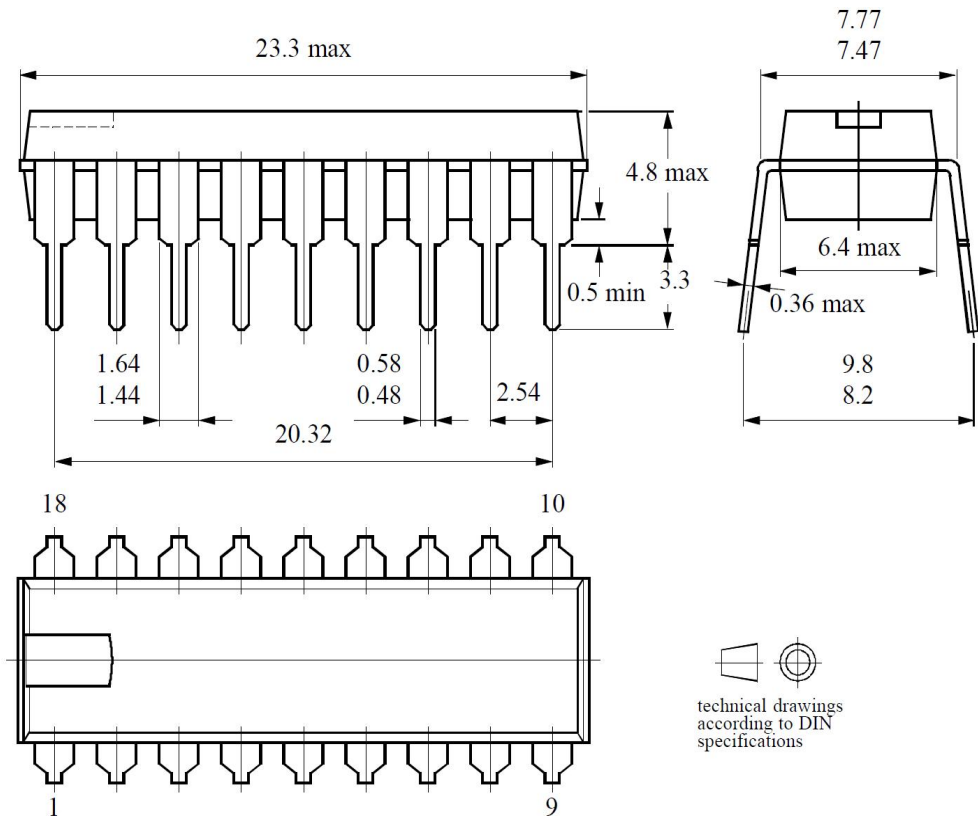

Package SO16

Dimensions in mm

