

SCHEMATIC

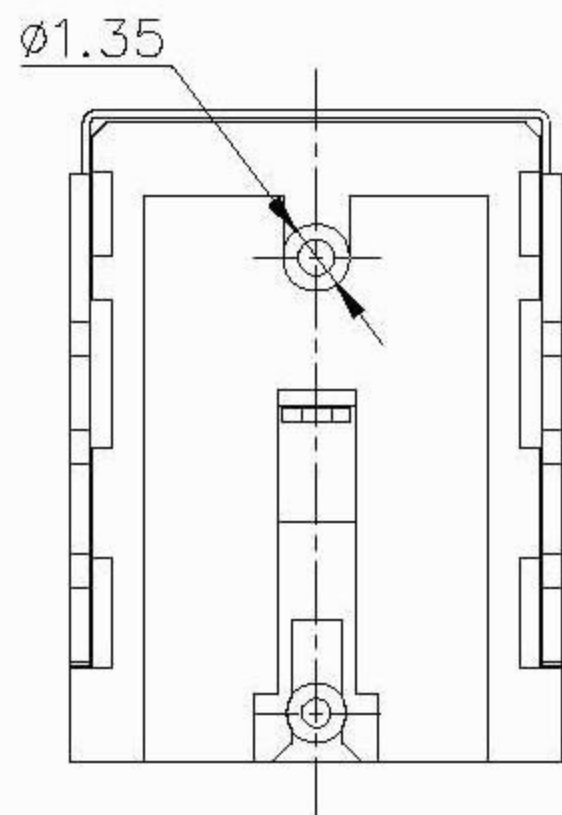
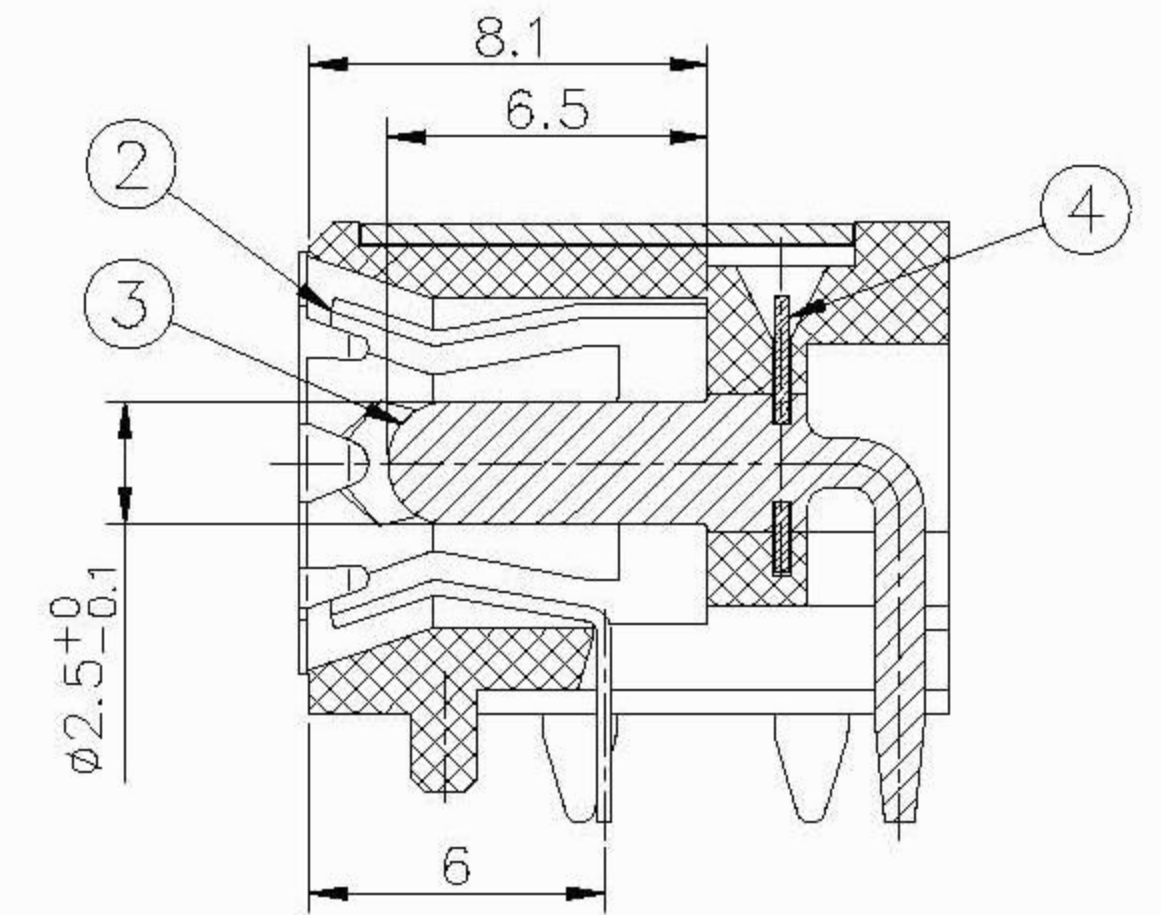
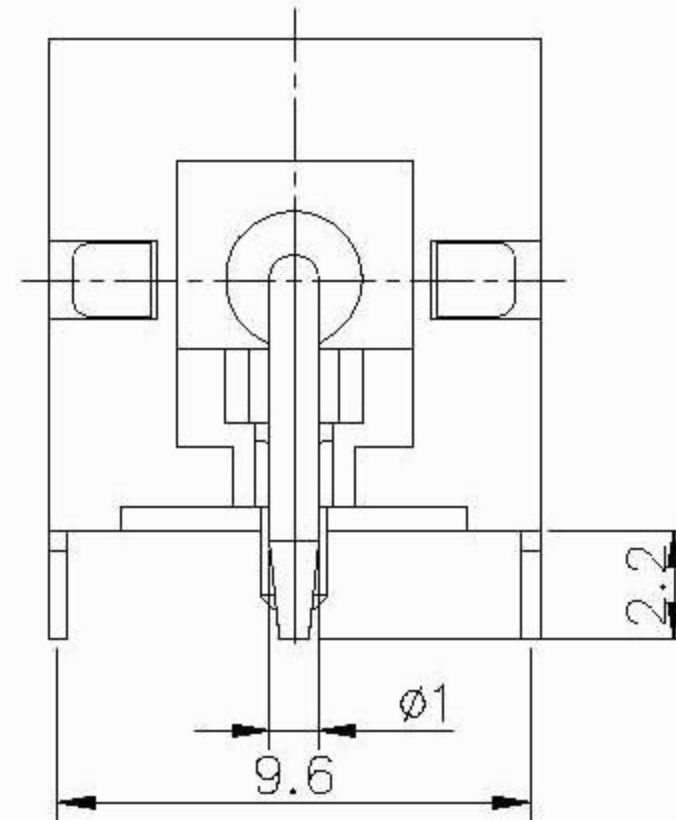
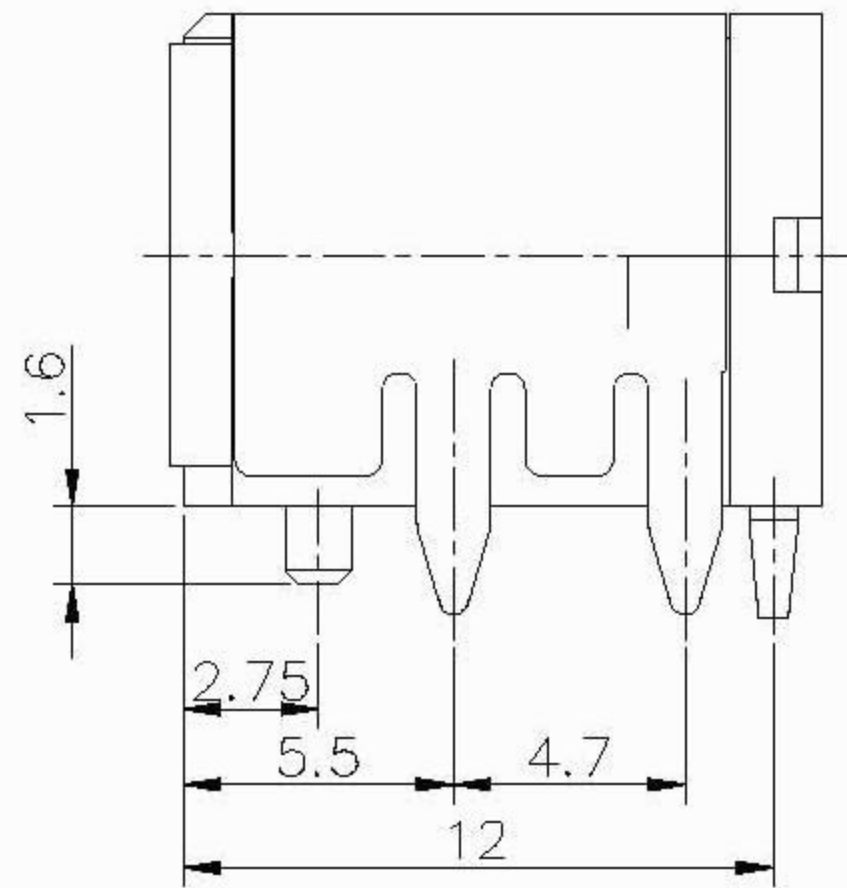
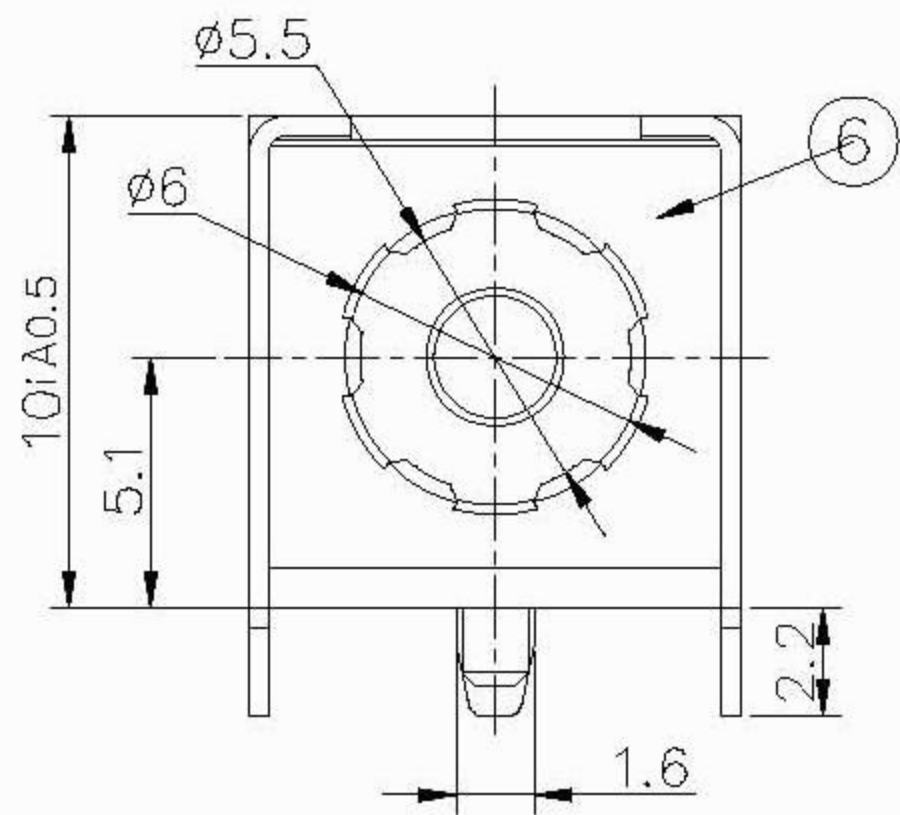

6	GROUND	1	SUS 304 0.15t	
5	SHEEL	1	SPCC-SD 0.4t	CuSn-PLATING
4	TERMINAL	1	SUS 301 0.3t	
3	PIN	1	BRASS BAR	AG-PLATING
2	SPRING	1	COPPER ALLOY 0.3t	CuSn-PLATING
1	HOUSING	1	HIGH TEMP. THERMOPLASTIC	UL 94V-0
LTR		QTY	MATERIAL (THICK, COLOR)	REMARK

ANGULAR	$\pm 5^\circ$
$16 < L \leq 63$	± 0.4
$4 < L \leq 16$	± 0.3
$L \leq 4$	± 0.2
UNSPECIFIED TOLERANCE	

L&X 深圳市连欣科技有限公司		NAME	DC 笔记本电源JACK	REVISION	A/0
DSND	DATE	SCALE:	1:1	PART:	
CHKD	DATE	VIEW:		XDJK-060B-055	
APVD	DATE	UNIT:	mm	DWN. NO.	
				WGXD-060B	