



Application Note: SY7803B

2A flash LED boost driver for smart phone Application

General Description

The SY7803B is a high efficiency, 2 MHz frequency synchronous Boost converter with two 1A constant current drivers for high current white LEDs. SY7803B could operate in Movie/Torch mode or Flash mode. There is timeout function in flash mode. It's convenient to program two mode's LED current by external resistors respectively. It is an ideal power solution for WLED photo flash applications within small PCB layout dimension and used in Lithium-ion/polymer battery operated products.

The SY7803B is available in a RoHS compliant 14-lead 3x2x0.75mm DFN.

Ordering Information

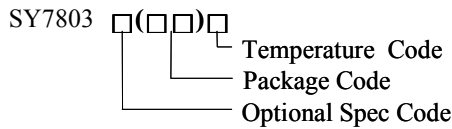

Ordering Number	Package Type	Note
SY7803BDUC	DFN3*2-14	-----

Features

- Input voltage range: 2.7V to 5.5V.
- 2MHz switching frequency to achieve small total solution size.
- Drive up to total 2A or 1A per channel in flash mode
- Timeout function in flash mode
- Independent flash-mode enable and movie/torch-mode enable pins
- Movie/torch-mode dimming via PWM control
- One resistor sets flash-mode LED current
- One resistor sets movie/torch-mode LED current
- Low R_{dson} of internal FET: 100m ohm for PFET and 200m ohm for NFET.
- LED open/short protection
- Over-voltage protection
- 0.1 μA shutdown current
- Thermal shut down.
- -40 to +85 C° Temperature Range
- Pb-free Package: DFN3x2-14

Applications

- Smart phone/digital camera LED flash.
- White LED driver.

Typical Applications

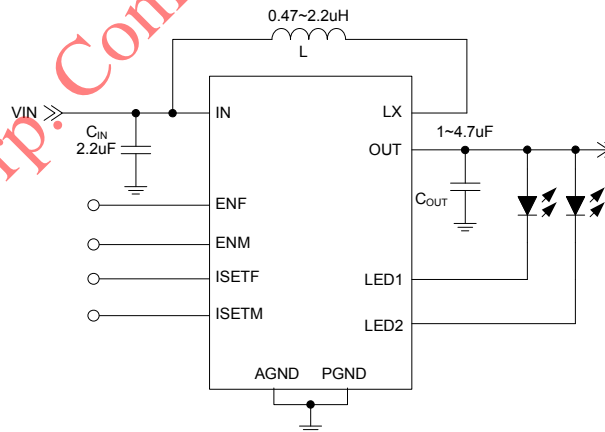
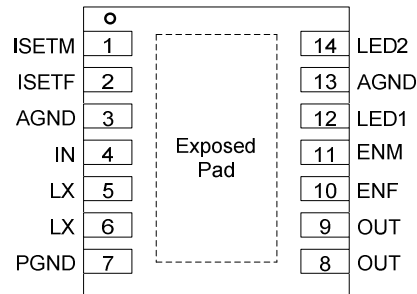

Fig.1 schematic

Pinout (top view)

(DFN3×2-14)

Top Mark: Dfxyz (Device code: Df; x=year code, y=week code, z=lot number code)

Pin Name	Pin Number	Pin Description
LED1	12	Regulated output current source #1, up to 1A current. Pins LED1 and LED2 can be connected together to sink 2A combined.
LED2	14	Regulated output current source #2, up to 1A current. Pins LED1 and LED2 can be connected together to sink 2A combined.
OUT	8, 9	Boost output. Connect a 2.2uF ceramic capacitor from OUT to PGND.
LX	5, 6	Inductor node. Connect an inductor from power input to LX pin.
AGND	3,13	Analog Ground.
PGND	7	Power Ground.
ENM	11	MOVIE/TORCH mode enable. This pin has an internal 300kΩ resistor pull down to AGND.
ENF	10	Flash mode enable pin. This pin has an internal 300kΩ resistor pull down to AGND.
IN	4	Power supply input pin. Decouple this pin to PGND pin with 2.2uF ceramic capacitor. It receives the input from 2.7V to 5.5V.
ISETF	2	Flash mode current setting pin.
ISETM	1	Movie/torch mode current setting pin
Exposed PAD		Connected to Analog Ground pin for electrical and thermal usage.

Absolute Maximum Ratings (Note 1)

IN, LX, OUT-----	6V
All other pins -----	VIN+0.3 / 6V
Power Dissipation, P _D @ TA=25°C -----	1.28 W
Package Thermal Resistance (Note 2)	
θ _{JA} -----	78°C/W
Junction Temperature Range -----	-150°C
Lead Temperature (Soldering, 10 sec.) -----	300°C
Storage Temperature Range -----	-65°C to 150°C

Recommended Operating Conditions (Note 3)

IN, LX, OUT-----	2.7V to 5.5V
All other pins -----	VIN+0.3 / 5.5V
Junction Temperature Range -----	-40°C to 125°C
Ambient Temperature Range -----	-40°C to 85°C

Block Diagram

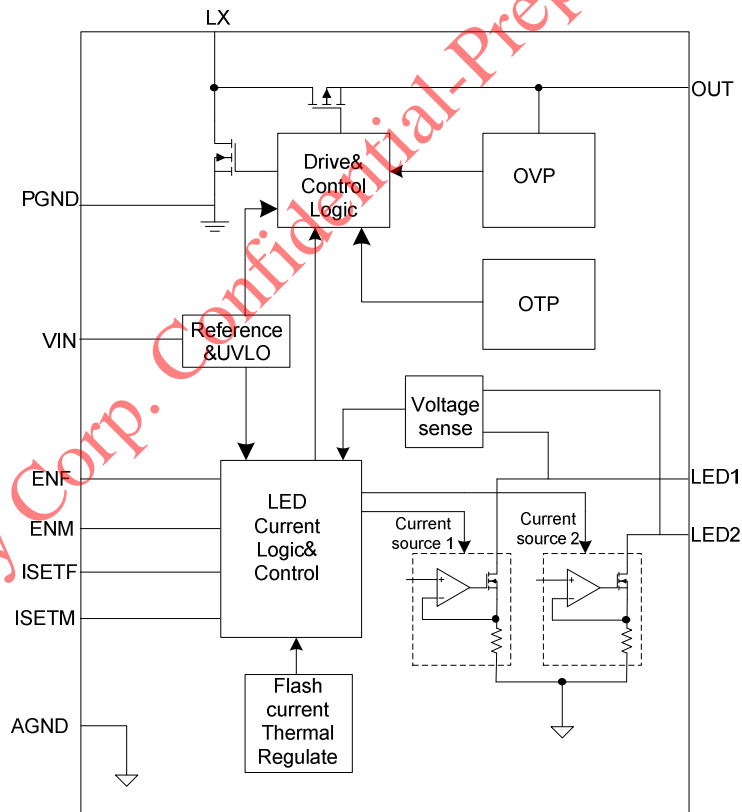



Electrical Characteristics

($V_{IN} = 3.6V$, $T_A = 25^{\circ}C$ unless otherwise specified)

Parameter	Symbol	Test Conditions	Min	Typ	Max	Unit
Input Voltage Range	V_{IN}		2.7		5.5	V
Quiescent Current	I_Q	ENM='1', ENF='1', ILED=0			1500	μA
Shutdown Current	I_{SHDN}	ENM='0', ENF='0'		0.1	1	μA
NFET RON	$R_{DS(ON)1}$			200		m Ω
PFET RON	$R_{DS(ON)2}$			100		m Ω
NFET Current Limit	I_{LIM1}	Default current limit level		3.5		A
OVP rising threshold	OVPth			5.3		V
OVP hysteresis	OVP _{hys}			120		mV
Flash mode soft start time	T _s			100		μs
Maximum Output Current	I_{MAX}			2		A
Flash timeout	T _{timeout}	ENF='1'		1.024		S
LED Current Accuracy	ILEDA	1A flash current setting per channel			± 13	%
		50mA torch current setting per channel			± 11	%
Current Source Regulation Voltage				300		mV
Dimming Frequency	F _{dim}		100		1k	Hz
Switching Frequency	F _{sw}	Boost at CCM mode. If load is slight, switching frequency will decrease.		2		MHz
Input Logic Low	V_{IL}				0.4	V
Input Logic High	V_{IH}		1.4		V_{IN}	V
VIN UVLO rising threshold	V_{INUVLO}		2.1	2.4	2.68	V
UVLO hysteresis	UVLO _{HYS}			0.1		V
Thermal Shutdown Temperature	T _{SD}			150		$^{\circ}C$

Note 1: Stresses beyond the “Absolute Maximum Ratings” may cause permanent damage to the device. These are stress ratings only. Functional operation of the device at these or any other conditions beyond those indicated in the operational sections of the specification is not implied. Exposure to absolute maximum rating conditions for extended periods may affect device reliability.

Note 2: θ_{JA} is measured in the natural convection at $T_A = 25^{\circ}C$ on a low effective single layer thermal conductivity test board of JEDEC 51-3 thermal measurement standard.

Note 3: The device is not guaranteed to function outside its operating conditions.

Typical Performance Characteristic

($V_{IN} = 3.6V$, $I_{Flash} = 1A$, $I_{Torch} = 200mA$, 1 PCS LED per string, 2 strings)

Torch mode Efficiency

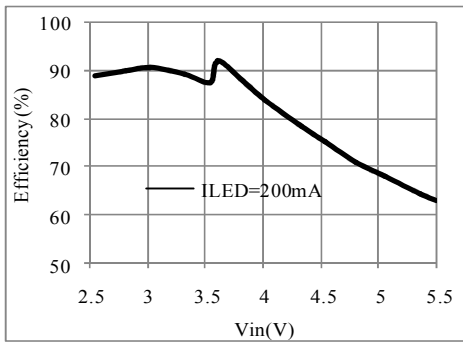

Flash Timeout

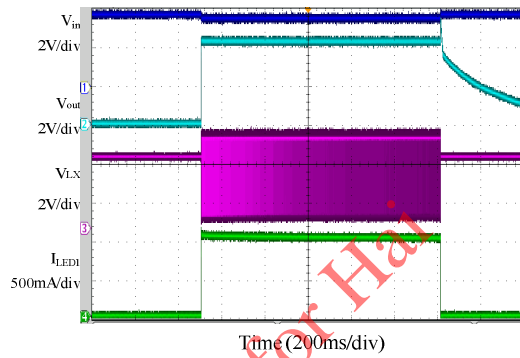

Torch Turn on from Vin

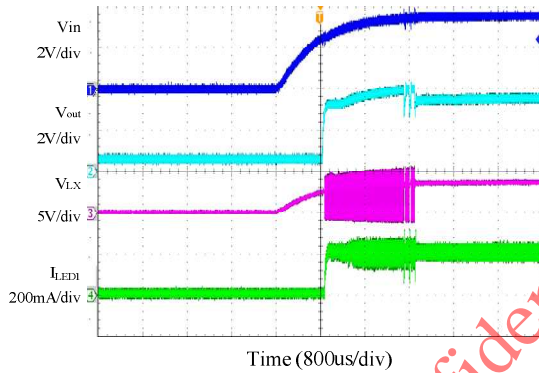

Torch Turn on from EN

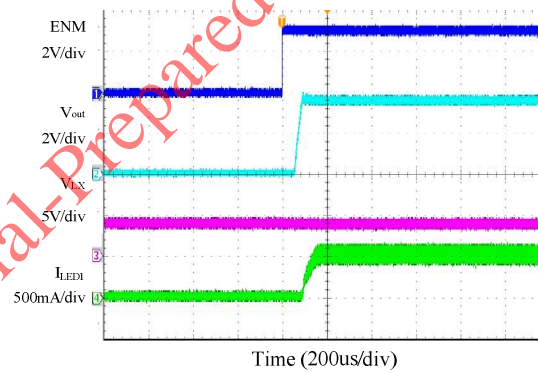

Torch Mode Dimming

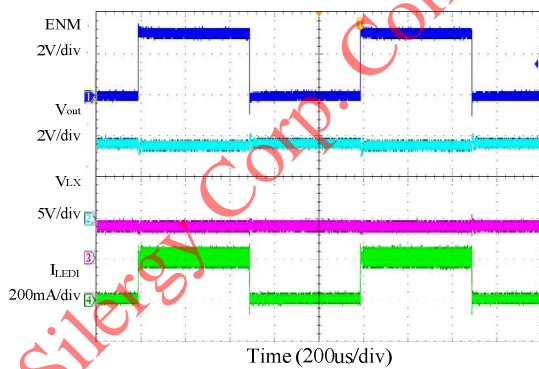

Torch Mode Dimming

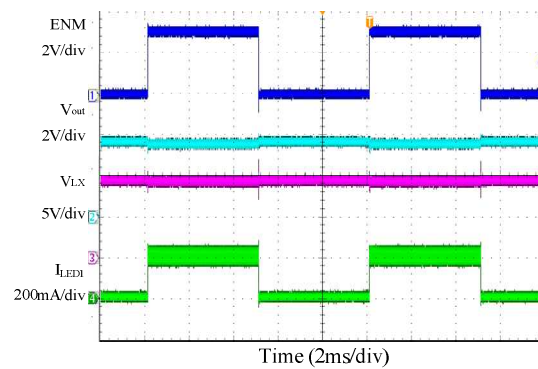



Function Description

SY7803B is a 2MHz switching frequency boost flash LED driver capable of delivering up to 1A of LED current into a single LED, or up to 2A into two parallel LEDs.

Enabling the Device:

The driver IC and two current sources will be shut down if both ENF and ENM are low. If ENM is high and ENF is low, the LED current will be ramped up to the movie/torch mode. If ENF is high whether ENM is high or low, the LED current will be ramped up to Flash mode. To enable the device pull ENM or ENF pin high. The reference and LDO are enabled first. On start-up, when V_{OUT} is less than V_{IN} , the internal synchronous PFET turns-on as a current source and delivers 350mA to the output capacitor to prevent the input inrush current. When V_{OUT} reaches 2.2V the current source can turn on.

Boost Mode& Pass Mode:

SY7803B can select the operation mode according the input voltage and output voltage. It works in Pass mode if the input voltage is higher than the output voltage. When the input voltage is not high enough to supply the LED current, it will shift to the Boost automatically.

Movie/Torch-Mode:

Movie/torch-mode LED current can be programmed up to a maximum total current of 400mA or up to 200mA per channel by setting the ISETM resistor. For the desired movie/torch-mode current in each output, the resistor value can be calculated using the following equation.

$$I_{MOVIE(LED1)} = I_{MOVIE(LED2)} = 6800 / R_{ISETM}$$

For additional flexibility, a lower movie/torch mode current than the value calculated above can be realized by applying a PWM dimming signal at ENM pin while ENF is held low. The average movie/torch-mode current will be proportional to the PWM duty ratio. Dimming signal frequency is from 100Hz to 1kHz.

Flash-Mode:

Flash-mode LED current can be programmed up to a

maximum total current of 2A or up to 1A per channel by setting the ISETF resistor. For the desired flash-mode current in each output, the resistor value can be calculated using the following equation.

$$I_{FLASH(LED1)} = I_{FLASH(LED2)} = 6800 / R_{ISETM}$$

Flash current automatically terminated when timeout is over.

Automatic thermal regulation control is active when SY7803B is in flash mode. If flash mode is enabled and the flash current is set to a high current value, the temperature of the IC can increase quickly. Once the IC's temperature goes above 100°C, the two sinks' currents will be automatically decreased according to the thermal regulation control loop. This can prevent the IC from triggering thermal shutdown and causing the LEDs to flicker. Depending on the thermal layout of the PCB and the flash mode current setting, the SY7803B sink current can be lower than the programmed value due to the thermal regulation protection feature.

LED Short Protection:

When the SY7803B is enabled, a 1mA current is sourced to each LEDx pin. If any LED becomes shorted, the voltage between V_{OUT} and each sink node (LED1 and LED2) will be less than 1V. IC will disable this LED channel. However the 1mA sensing current will be kept to generate the LED's voltage drop. If the short circuit is removed during operation, the channel will automatically recover to the programmed current setting

LED Open Protection:

In case of LED open, the open channel will control the loop first and V_{OUT} will reach OVP (approximately 5.3V), then SY7803B will automatically detect which channel's LED is open and disable that channel. From that point, the other channel with properly operating LED will control the loop and V_{OUT} will be regulated down to a normal operating voltage. Open-circuit LED fault protection is reset when the IC is powered down and up again.

Over-temperature protection:

When the SY7803B's die temperature reaches +150°C, the chip will shutdown. The SY7803B will not start up again until the die temperature falls to below +130°C or the power is recycled.

Applications Information

Input capacitor C_{IN}:

The ripple current through input capacitor is calculated as:

$$I_{CIN_RMS} = \frac{V_{IN} \times (V_{OUT} - V_{IN})}{2\sqrt{3} \times L \times F_{SW} \times V_{OUT}}$$

X5R or X7R ceramic capacitors with greater than 2.2uF capacitance are recommended to handle this ripple current. To minimize the potential noise problem, place this ceramic capacitor really close to the IN and PGND pin.

Output capacitor C_{OUT}:

The output capacitor is selected to handle the output ripple noise requirements. This ripple voltage is related to the capacitance and its equivalent series resistance (ESR). For the best performance, it is recommended to use X5R or better grade low ESR ceramic capacitor. The voltage rating of the output capacitor should be higher than the maximum output voltage. The minimum required capacitance can be calculated as:

$$C_{OUT} = \frac{I_{LED} \times (V_{OUT} - V_{IN})}{F_{SW} \times V_{OUT} \times V_{RIPPLE}}$$

V_{RIPPLE} is the peak to peak output ripple. For LED applications, the equivalent resistance of the LED is typically low. The output capacitance should be large enough to attenuate the ripple current through LED.

Inductor L:

There are several considerations in choosing this inductor.

- 1) Choose the inductance to provide the desired ripple current. It is suggested to choose the ripple current to be lower than 40% of the maximum average input current. The inductance is calculated as:

$$L = \left(\frac{V_{IN}}{V_{OUT}} \right)^2 \frac{(V_{OUT} - V_{IN})}{I_{LED} \times F_{SW} \times 40\%}$$

F_{SW} is the switching frequency, I_{LED} is the total current of two LED string.

- 2) The saturation current rating of the inductor must be selected to be greater than the peak inductor current under full load conditions.

$$I_{SAT_MIN} > \left(\frac{V_{OUT}}{V_{IN}} \right) \times I_{LED} + \left(\frac{V_{IN}}{V_{OUT}} \right)^2 \frac{(V_{OUT} - V_{IN})}{2 \times F_{SW} \times L}$$

- 3) The DCR of the inductor and the core loss at the switching frequency must be low enough to achieve the desired efficiency requirement.

1uH inductor is recommended (see Table 1).

Table 1. Recommended Inductor for SY7803B

Part Number	L (uH)	DCR (mΩ)	Saturation Current (A)	Dimensions (L×W×H) (mm)
SPM4015T-1R0M	1	39.6	8.9	4.4×4.1×1.5

Layout Design:

Proper PCB layout and components placement are critical to the performance of the IC and to prevent noise and electromagnetic interference problems. Following are some rules for the PCB layout:

- 1) The loop of OUT pin, output capacitor and PGND pin must be as short as possible
- 2) It is desirable to maximize the PCB copper area connecting to PGND/AGND pin to achieve the best thermal and noise performance.
- 3) C_{IN} must be close to IN pin and PGND. The loop area formed by C_{IN} and PGND must be minimized.
- 4) The PCB copper area associated with LX pin must be minimized to avoid the potential noise problem.
- 5) The small signal components must be placed close to IC and must NOT be adjacent to the LX net on the PCB layout to avoid the noise problem.

DFN3x2-14 Outline Drawing

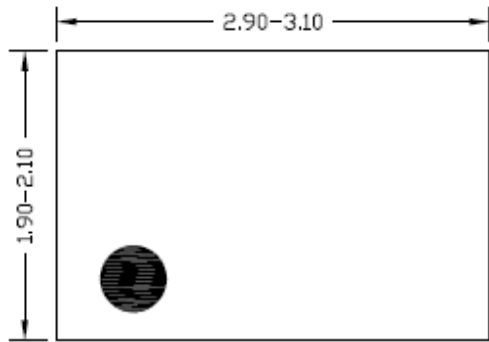

Top View

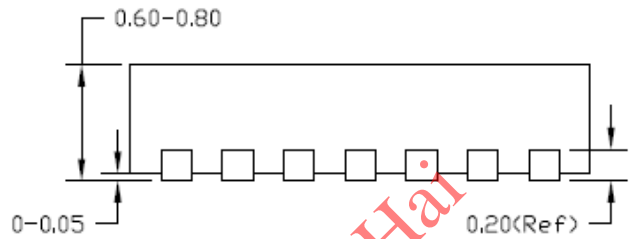

Side View

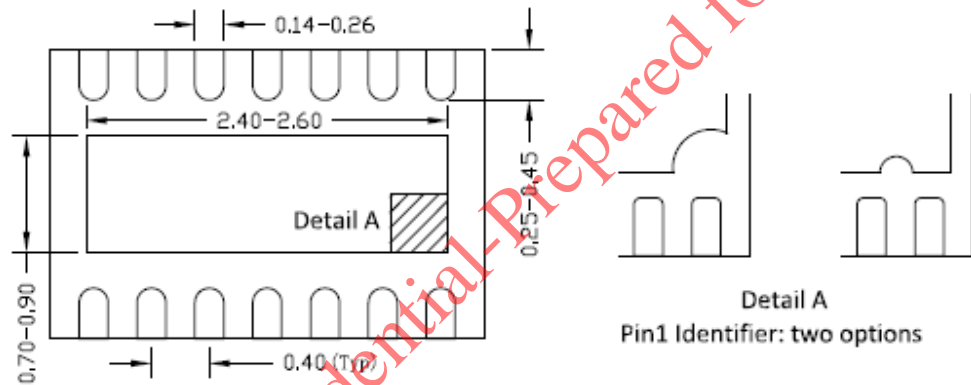

Bottom View

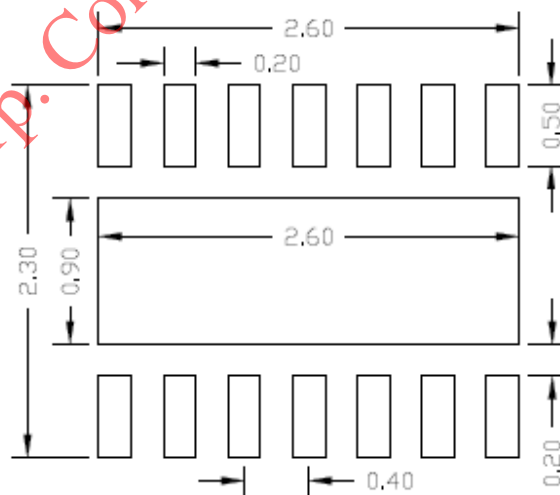

Recommended PCB layout (Reference only)

Notes: All dimension in millimeter and exclude mold flash & metal burr

Taping & Reel Specification

1. Taping orientation

DFN3x2

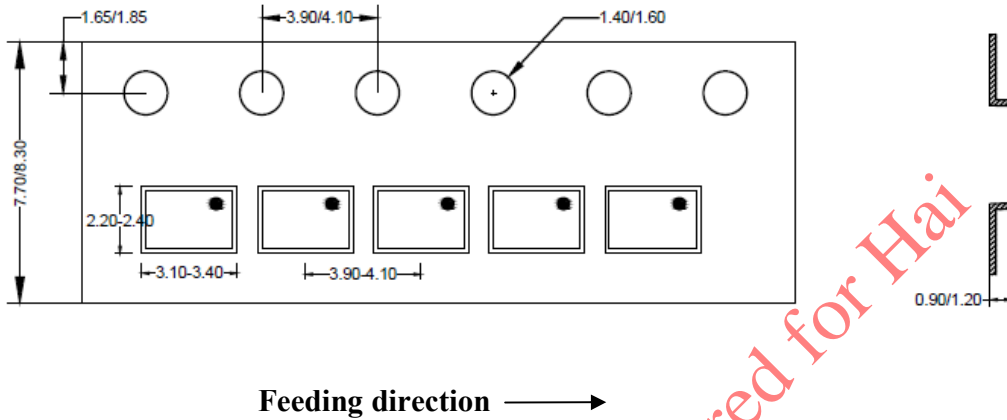

2. Carrier Tape & Reel specification for packages

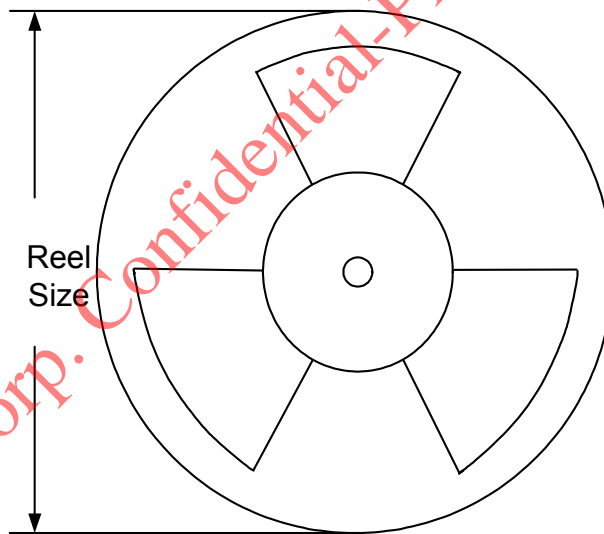

Package type	Tape width (mm)	Pocket pitch(mm)	Reel size (Inch)	Trailer length(mm)	Leader length (mm)	Qty per reel (pcs)
DFN3x2-14	8	4	7"	400	160	3000

3. Others: NA