

8 7 6 5 4 3 2 1

THE INFORMATION CONTAINED IN THIS DRAWING IS THE SOLE PROPERTY OF L-COM, INC. ANY REPRODUCTION IN PART OR WHOLE WITHOUT THE WRITTEN PERMISSION OF L-COM, INC. IS PROHIBITED.

REVISIONS			
REV	DESCRIPTION	DATE	APPROVED
A	INITIAL RELEASE	10/21/2021	S.XU

FIBER TYPE	SINGLEMODE, BEND TOLERANT, MIL TAC
CORE DIAMETER	9 μm
CLADDING DIAMETER	125 μm
PRIMARY COATING DIA. (UV CURED ACRYLATE)	245 μm
SECONDARY BUFFER DIA. (HARD ELASTOMERIC)	900 μm
NUMERICAL APERTURE	0.20
PROOF TEST LEVEL	100 kpsi

WAVELENGTH:	1310 nm	1550 nm
MAXIMUM ATTENUATION	0.5 dB/km	
NOMINAL ZERO DISPERSION SLOPE	0.092 ps/(nm ² -km)	

CABLE WEIGHT	36 kg/km (24 lbs/1000 ft)
CABLE DIAMETER	6.5 mm (0.26 in)

SHORT-TERM:	
MAX TENSILE LOAD	550 N (120 lbs)
MIN BEND RADIUS	6.5 cm (2.6 in)

LONG-TERM:	
MAX TENSILE LOAD	275 N (60 lbs)
MIN BEND RADIUS	3.3 cm (1.3 in)

IMPACT RESISTANCE, EIA/TIA-455-25A, MIL REQ	1500 IMPACTS
CRUSH RESISTANCE, EIA/TIA-455-41A, MIL REQ	2200 N/cm

OPERATING TEMPERATURE	-55°C TO +85°C
STORAGE TEMPERATURE	-70°C TO +85°C

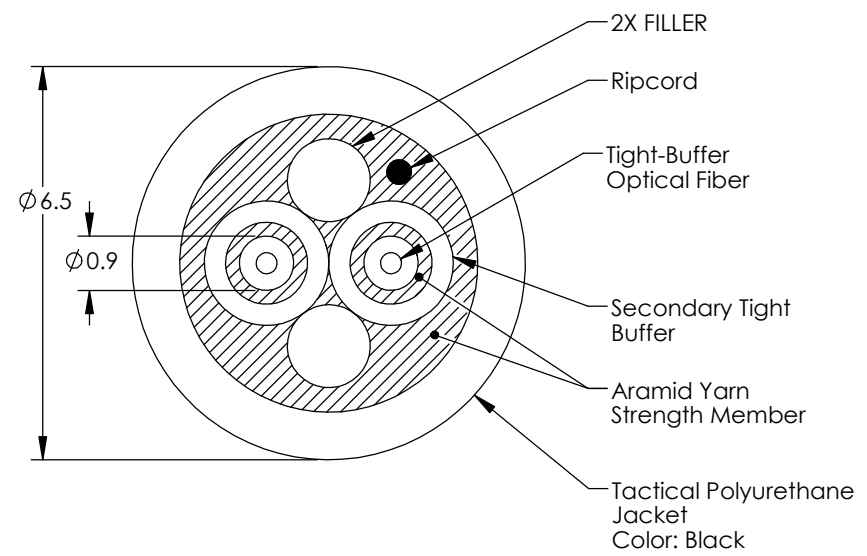
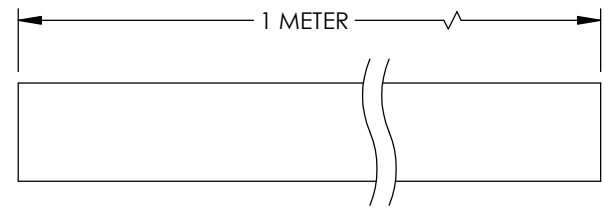

ALL DIMENSIONS IN mm, DRAWING NOT TO SCALE

NOTES:

1. CABLE SHALL BE INDIVIDUALLY PACKAGED IN ACCORDANCE WITH L-COM SPECIFICATION PS-0031.

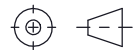
UNLESS OTHERWISE SPECIFIED, DIMENSIONS ARE IN INCHES [mm] OVERALL CABLE LENGTH TOLERANCE: ≤12 [305] = +1 [25] / -0 >12 [305] ≤60 [1524] = +2 [51] / -0 >60 [1524] ≤120 [3048] = +4 [102] / -0 >120 [3048] ≤300 [7620] = +6 [152] / -0 >300 [7620] = +5% / -0 ALL OTHER DIMENSIONAL TOLERANCES: .X = ± .2 [5] FRACTIONS ± 1/32 .XX = ± .02 [5] ANGLES ± 1° .XXX = ± .005 [13]	APPROVALS	DATE	 50 High Street, West Mill, North Andover, MA 01845 USA. Phone: 1.800.341.5266 1.978.682.6936		
	DRAWN BY BZHANG	09/14/2021			
	CHECKED BY S.XU	09/14/2021			
	APPROVED BY S.XU	09/14/2021			
THIRD-ANGLE PROJECTION	CONFIGURATION DETAILS OF UNDIMENSIONED FEATURES MAY VARY	CATEGORY FIBER OPTIC			
	COLOR VARIATIONS MAY OCCUR	PRODUCT DESCRIPTION 1M Interval Economy SMF 9/125 2-count Breakout Fiber Cable 2.5mm OD Black Military Rated			
		SIZE A	CAGE CODE 43321	ITEM NO. FOB25SNGMKB2V-M	REV. A
		SCALE: NONE	CAD FILE: FOB25SNGMKB2V-M.SLDDRW	SHEET 1 OF 1	