



电位器规格书

POTENTIOMETER SPECIFICATIONS

1 一般事项 General information	
1-1 适用型号 Applicable models	R120 系列带开关型 R120 Serial have Switch type
1-2 使用环境温度 Usage environment temperature	- 20℃ ~ + 70℃
1-3 保存环境温度 Storage environment temperature	- 40℃ ~ + 70℃
1-4 测试条件 Test condition	温度: 5~35℃, 湿度: 45~85%HR Temperature:5~35℃, Moisture:45~85%HR
1-5 环保要求 Environmental requisition	本产品符合 RoHS 指令 This product is compliant with RoHS Directive
1-6 耐焊接热 Soldering heat-resistance	1、手工焊接温度最高 350℃ ± 5℃, 3 秒; 2、自动焊接温度最高 260℃ ± 5℃, 3 秒; 基板表面预热温度最高 100℃, 1 分钟以内; 3、以上过程均保证在 1 到 2 次。 1. Soldering iron Max ,350℃ ± 5℃ at 3 sec 2. Auto soldering 260℃ ± 5℃ max. at 3 Sec. Preheating temperature of board surface: 100℃ max. at within 1 minutes. 3. To guarantee the above process at 1 or 2 times.
1-7 原产地 Country of origin	中国 China
2 构造 CONSTRUCTION) condition	
2-1 外观 Appearance	各部件应完整, 无锈蚀、裂痕、电镀不良 Every part should finished, not exist rust flaw crack and bad plating
2-2 寸法 Measurements	依照图面规定 Under conditions prescribed by design drawing.
3 机械性能 Mechanical characteristics	
3-1 全回转角度 Total rotational angle	230° ± 10°
3-2 回转力矩 Rotational torque	20~100gf.cm (旋转速度: 60° /1 秒) 20~100gf.cm (Rotational velocity : 60° /1 Sec.)
3-3 回转止动强度 Rotational stopper strength	最小 2Kgf.cm 2Kgf.cm Min.
3-4 轴压引强度 Pull-Push Strength of Shaft	牵引: 最小 0Kgf 按压: 最小 1Kgf Pull: 0Kgf Min. Push: 1Kgf Min.
3-5 端子铆压强度 Terminal riveted strength	≥0.3Kg
3-6 轴摇晃度 Shaft wobble	在轴芯顶端施加 250gf, 轴径向偏移量小于: 1.0*轴长 L 尺寸/20mm On the tip of the shaft exert 250gf , Shaft radial deviant be smaller than: 1.0*shaft long L size/20mm

4 电气性能 Electrical characteristics				
4-1 全阻抗值 Total resistance	<input checked="" type="checkbox"/> 10 K Ω \pm 20% <input type="checkbox"/> _____ K Ω \pm 10%			
4-2 阻抗变化特性 Resistance taper	<input type="checkbox"/> A <input checked="" type="checkbox"/> B <input type="checkbox"/> C <input type="checkbox"/> _____			
4-3 残留阻抗值（端子：1-2，2-3） End resistance（Terminal :1-2, 2-3）	R \leq 10K Ω : 10 Ω 10K Ω < R \leq 250K Ω : 20 Ω R > 250K Ω : 0.1% Max. of total resistance			
4-4 定格电力 Ratings power	B 线性：0.05W，其它线性：0.025W B Taper : 0.05W, Other taper : 0.025W			
4-5 最高使用电压 Maximum operating voltage	B 线性：10V DC 或 50V AC，其它线性：5V DC 或 25V AC B Taper :10V AC or 50V AC， Other taper : 5V DC or 25V AC			
4-6 滑动杂音 Slider noise	100mV 以下 100mV Max.			
4-7 绝缘抵抗 Insulation resistance	250V DC，100M Ω 以上 100M Ω Min. at 250V DC			
4-8 耐电压 Voltage proof	300V AC 1 分钟以上 1 Minute at 300V AC			
4-9 回转寿命 Rotational life	无负荷状态以每小时 600 周旋转，10,000 周以上，允许阻值最大变化 \pm 15%。 On the without load status according to the 600 r/h rotation, more than 10,000 cycles, permissible resistance change \pm 15% max.			
5 开关的性能 Switch characteristics				
5-1 开关型式 Switch type	旋转式 Rotation type			
5-2 开关回路 Switch circuit	单极单投 S.P.S.T			
5-3 开关定格电力 Switch ratings power	20V DC 600mA			
5-4 开关接触电阻 Switch contact resistance	寿命初期最大 100 m Ω ，寿命达到后最大 1 Ω Life prime 100 m Ω Max. After reach life 1 Ω Max.			
5-5 开关工作角度 Switch working angle	35 $^{\circ}$ \pm 10 $^{\circ}$			
5-6 开关工作力矩 Switch working torque	最大 500gf.cm 500gf.cm Max.			
5-7 开关寿命 Switch life	最少 10,000 次 10,000 cycles Min.			
东莞市长泰尔电子有限公司 DONG GUAN CHANG TAI ERELECTRONIC CO., LTD.		制作 Designed By	审核 Checked By	核准 Approved By
				

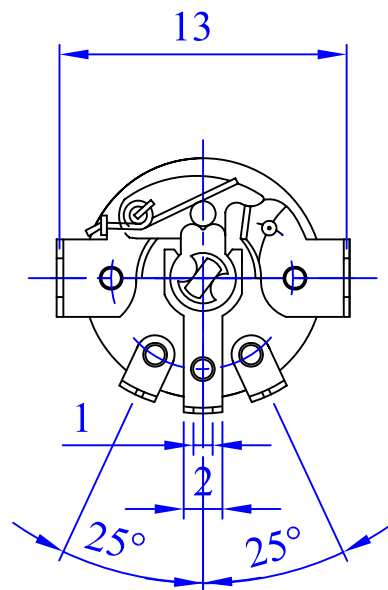
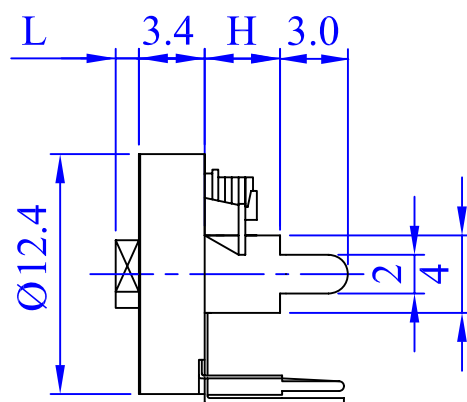
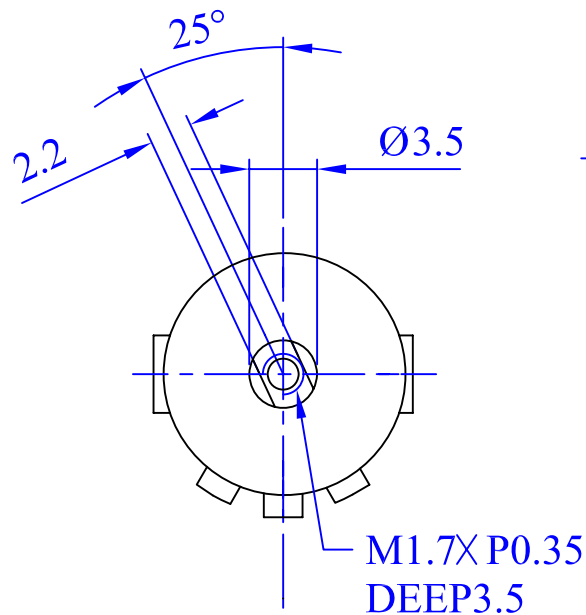
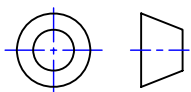

Mounting hole detail

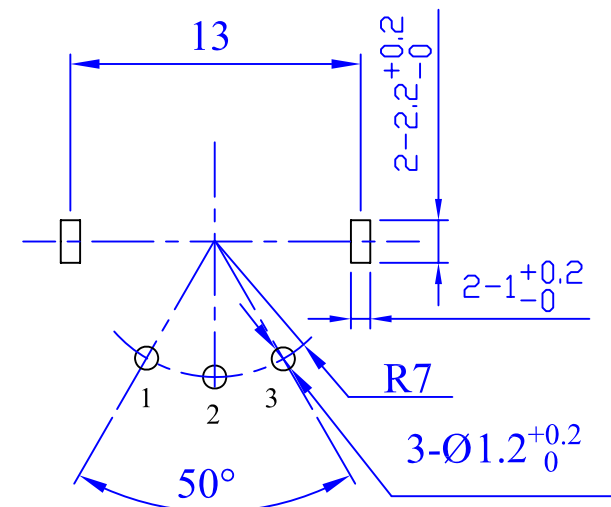

柄的规格

AA Shaft Style	AM Shaft Style	AK Shaft Style
L 1.2 2.2 5.3 6.0	L 1.2 2.2 5.3 6.0 0.9	L 3.0~5.0

CIRCUIT: NS

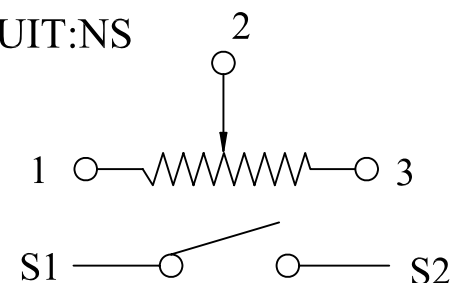

product code	H
R12012NS	3.0
R12022NS	3.9

未注尺寸公差	
L ≤ 1.0时	±0.1
1.0 < L ≤ 10时	±0.3
10 < L ≤ 30时	±0.5
30 < L ≤ 100时	±1.0

东莞市长泰尔电子有限公司								
比例	2.5:1	版本	1.1	设计	审核	批准		
品名	R120□ 2NS 组立图							
图号	R120□ 2NS							

东莞市长泰尔电子有限公司

DONG GUAN CHANG TAIER ELECTRONIC CO., LTD

阻抗变化特性 Resistance tapers

