

- ★ Green Device
- ★ Super Low Gate
- ★ Excellent CdV/dt effect decline
- ★ Advanced high cell density Trench technology
- ★ 100% EAS Guaranteed

Product Summary

BVDSS	RDSON	ID
60V	23mΩ	30A

Description

The 30N06 is the high cell density trenched N-ch MOSFETs, which provides excellent RDSON and and gate charge for most of the synchronous buck converter applications. The 30N06 meets the RoHS and Green Product requirement 100% EAS guaranteed with full function reliability approved.

TO252 Pin Configuration

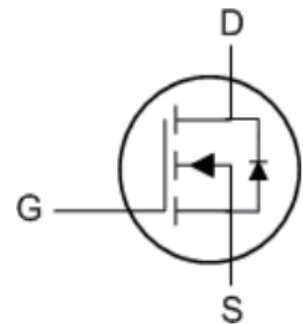
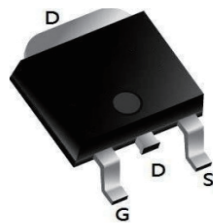

Absolute Maximum Ratings

Symbol	Parameter	Typ.	Max.	Units
V _{DSS}	Drain-Source Voltage		60	V
V _{GSS}	Gate-Source Voltage		±20	V
I _D	Continuous Drain Current	T _C = 25°C	30	A
		T _C = 100°C	13	A
I _{DM}	Pulsed Drain Current <small>note1</small>		100	A
EAS	Single Pulsed Avalanche Energy <small>note2</small>		39	mJ
P _D	Power Dissipation	T _C = 25°C	41.7	W
R _{θJC}	Thermal Resistance, Junction to Case		50	°C/W
T _J , T _{STG}	Operating and Storage Temperature Range		-55 to +175	°C

Electrical Characteristics ($T_J = 25^\circ\text{C}$ unless otherwise specified)

Symbol	Parameter	Test condition	Min.	Typ.	Max.	Units
Static Characteristics						
$V_{(BR)DSS}$	Drain-Source Breakdown Voltage	$V_{GS} = 0V, I_D = 250\mu A$	60	-	-	V
I_{GSS}	Gate-Body Leakage Current	$V_{DS} = 0V, V_{GS} = \pm 20V$	-	-	± 100	nA
I_{DSS}	Zero Gate Voltage Drain Current	$T_J = 25^\circ\text{C}$	-	-	1	μA
		$T_J = 100^\circ\text{C}$	-	-	100	
$V_{GS(th)}$	Gate-Threshold Voltage	$V_{DS} = V_{GS}, I_D = 250\mu A$	1.2	1.7	2.5	V
$R_{DS(on)}$	Drain-Source on-Resistance ⁴	$V_{GS} = 10V, I_D = 10A$	-	23	32	m Ω
		$V_{GS} = 4.5V, I_D = 5A$	-	31.5	40	
g_{fs}	Forward Transconductance ⁴	$V_{DS} = 5V, I_D = 10A$	-	15.5	-	S
Dynamic Characteristics⁵						
C_{iss}	Input Capacitance	$V_{DS} = 30V, V_{GS} = 0V,$ $f = 1\text{MHz}$	-	1355	-	pF
C_{oss}	Output Capacitance		-	60	-	
C_{rss}	Reverse Transfer Capacitance		-	49	-	
R_G	Gate Resistance	$f = 1\text{MHz}$	-	1.2	-	Ω
Switching Characteristics						
Q_g	Total Gate Charge	$V_{GS} = 10V, V_{DD} = 30V,$ $I_D = 10A$	-	22	-	nC
Q_{gs}	Gate-Source Charge		-	4.2	-	
Q_{gd}	Gate-Drain Charge		-	6.9	-	
$t_{d(on)}$	Turn-on Delay Time	$V_{GS} = 10V, V_{DD} = 30V,$ $R_G = 3\Omega, I_D = 10A$	-	6.4	-	ns
t_r	Rise Time		-	15.3	-	
$t_{d(off)}$	Turn-off Delay Time		-	25	-	
t_f	Fall Time		-	7.6	-	
t_{rr}	Body Diode Reverse Recovery Time		-	26	-	
Q_{rr}	Body Diode Reverse Recovery Charge	$I_F = 10A, dI_F/dt = 100A/\mu s$	-	45	-	nC
Drain-Source Body Diode Characteristics						
V_{SD}	Diode Forward Voltage ⁴	$I_S = 10A, V_{GS} = 0V$	-	-	1.2	V
I_S	Continuous Source Current	$T_C = 25^\circ\text{C}$	-	-	30	A

- Notes:
- 1.Repetitive rating, pulse width limited by junction temperature $T_J(\text{MAX}) = 150^\circ\text{C}$
 - 2.The EAS data shows Max. rating . The test condition is $V_{DD} = 25V, V_{GS} = 10V, L = 0.4\text{mH}, I_{AS} = 14A$
 - 3.The data tested by surface mounted on a 1 inch² FR-4 board with 2OZ copper, The value in any given application depends on the user's specific board design.
 - 4.The data tested by pulsed , pulse width $\leq 300\mu s$, duty cycle $\leq 2\%$.
 - 5.This value is guaranteed by design hence it is not included in the production test.

Typical Electrical and Thermal Characteristics (Curves)

Figure 1: Output Characteristics

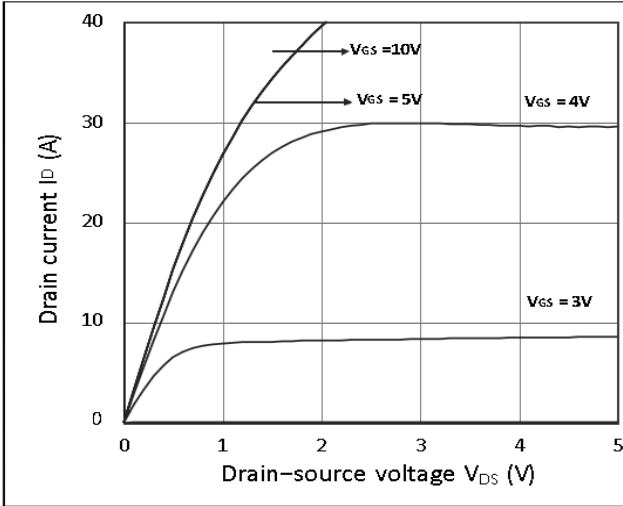

Figure 2: Transfer Characteristics

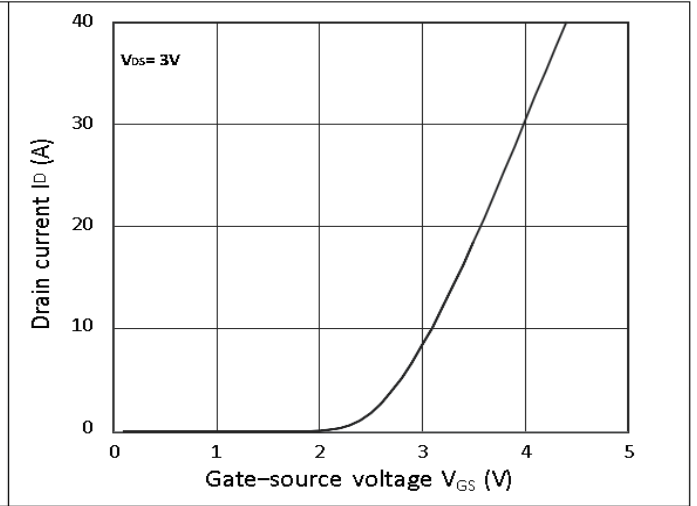

Figure 3: Forward Characteristics of Reverse

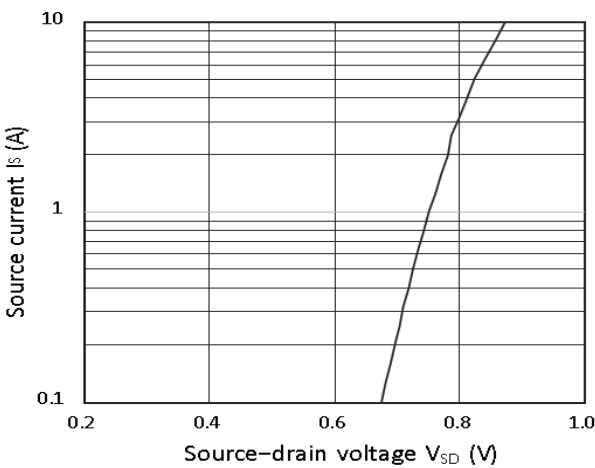

Figure 4: RDS(ON) vs. VGS

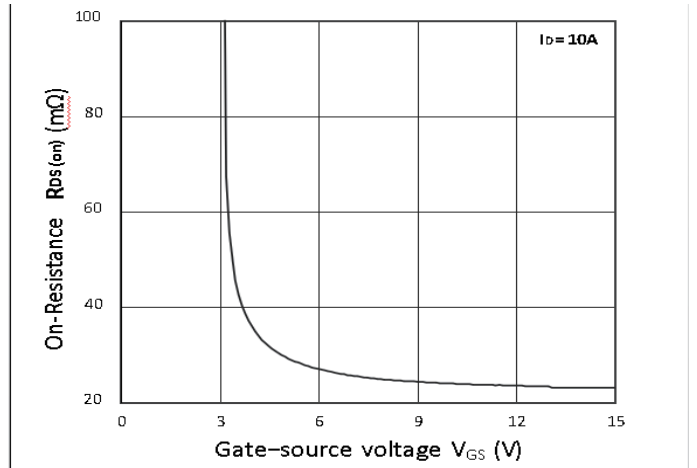

Figure 5: RDS(ON) vs. ID

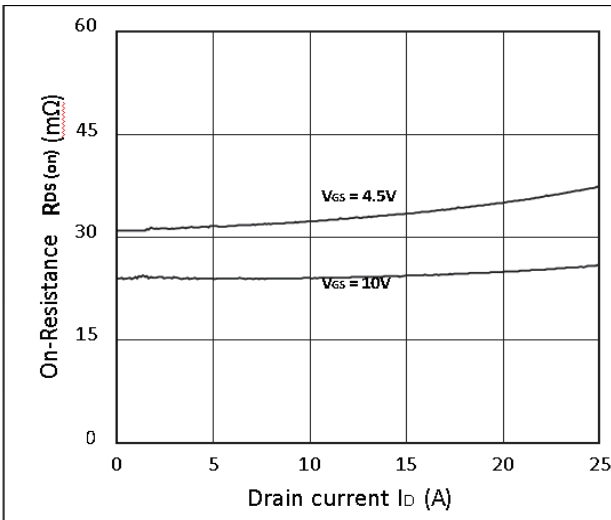
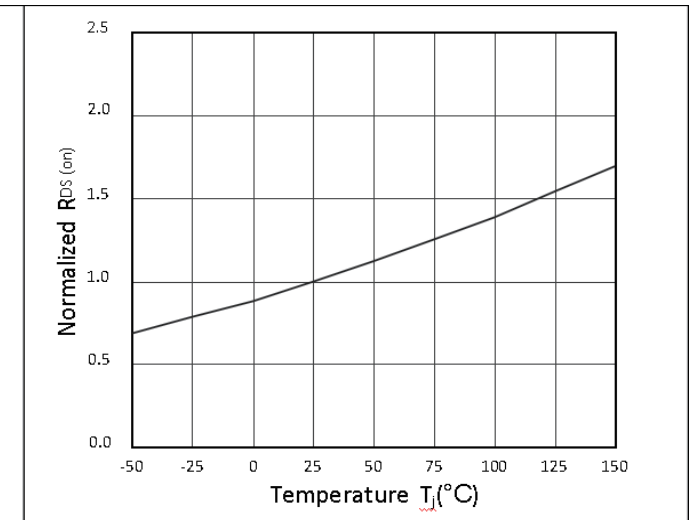

Figure 6: Normalized RDS(ON) v.s TJ



Typical Performance Characteristics

Figure 7: Capacitance

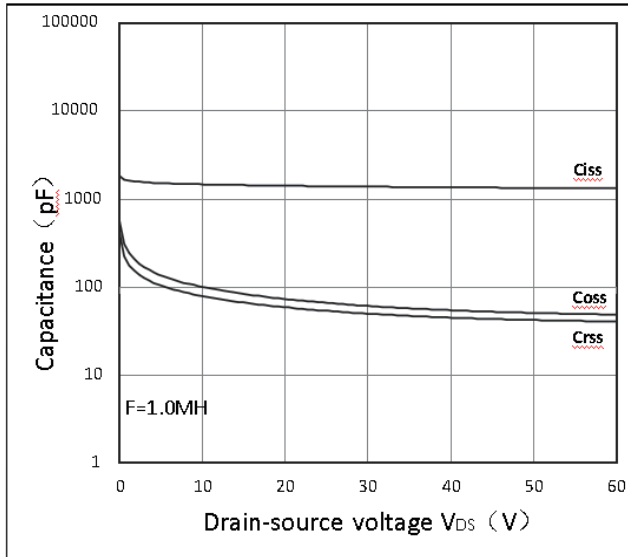

Figure 8: Gate Charge Characteristics

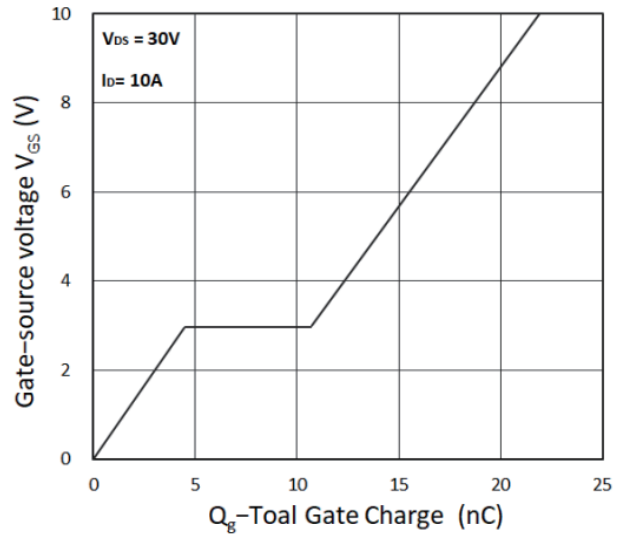

Figure 9: Normalized Maximum Transient

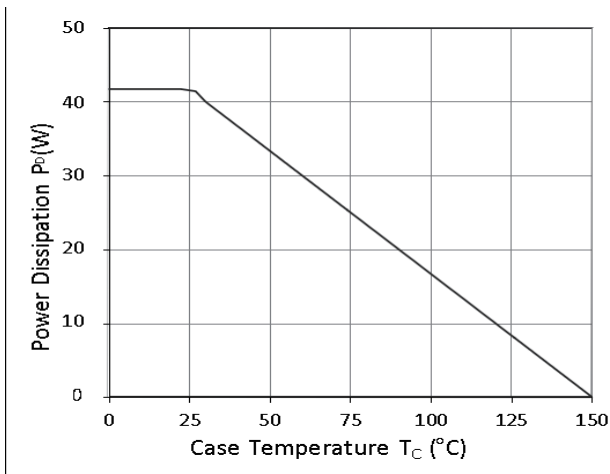

Figure 10: Safe Operating Area

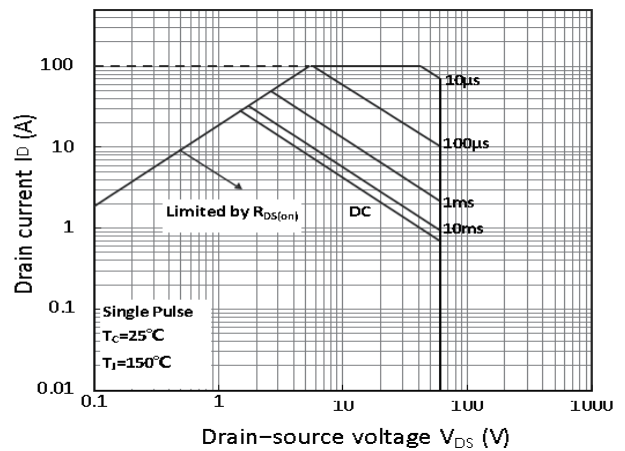
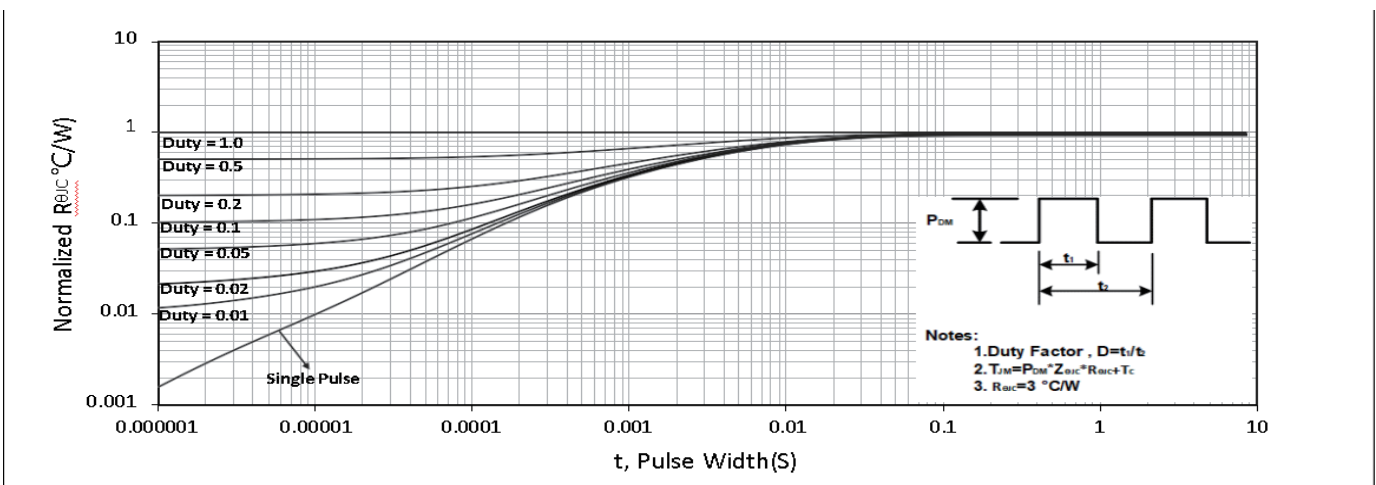
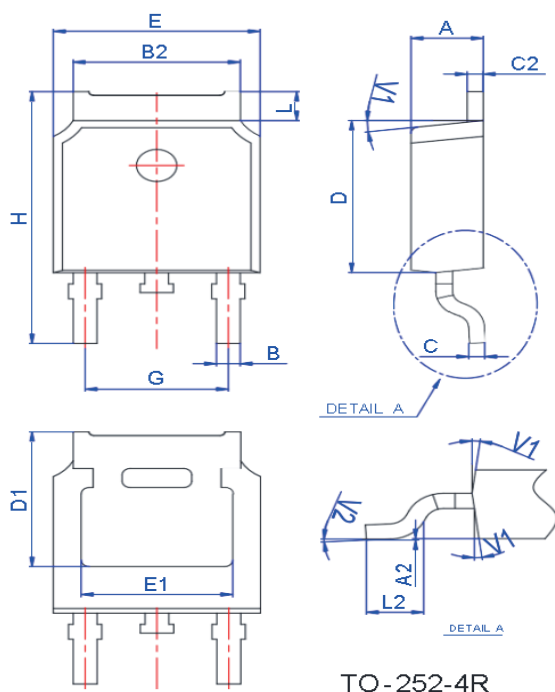

Figure 11: Normalized Maximum Transient



Package Mechanical Data-TO-252



Ref.	Dimensions					
	Millimeters			Inches		
	Min.	Typ.	Max.	Min.	Typ.	Max.
A	2.10		2.50	0.083		0.098
A2	0		0.10	0		0.004
B	0.66		0.86	0.026		0.034
B2	5.18		5.48	0.202		0.216
C	0.40		0.60	0.016		0.024
C2	0.44		0.58	0.017		0.023
D	5.90		6.30	0.232		0.248
D1	5.30REF			0.209REF		
E	6.40		6.80	0.252		0.268
E1	4.63			0.182		
G	4.47		4.67	0.176		0.184
H	9.50		10.70	0.374		0.421
L	1.09		1.21	0.043		0.048
L2	1.35		1.65	0.053		0.065
V1		7°			7°	
V2	0°		6°	0°		6°

Reel Specification-TO-252

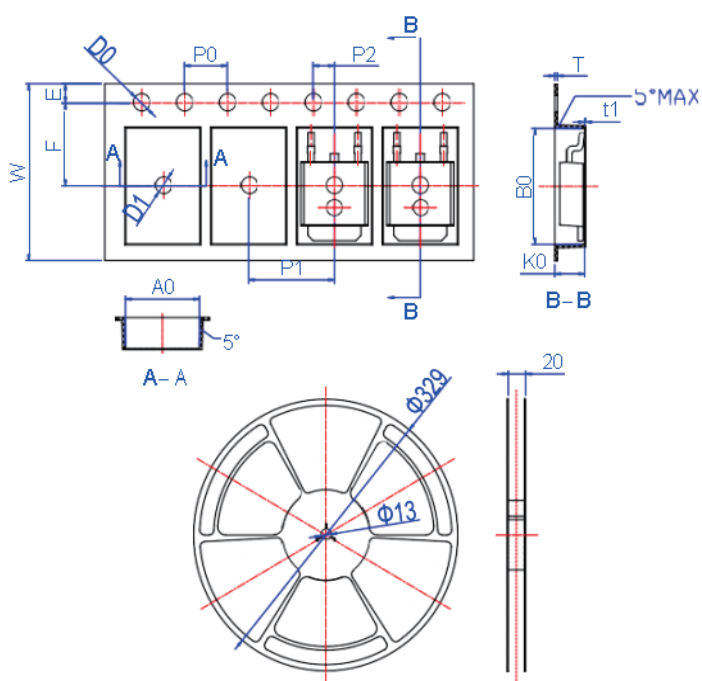

Ref.	Dimensions					
	Millimeters			Inches		
	Min.	Typ.	Max.	Min.	Typ.	Max.
W	15.90	16.00	16.10	0.626	0.630	0.634
E	1.65	1.75	1.85	0.065	0.069	0.073
F	7.40	7.50	7.60	0.291	0.295	0.299
D0	1.40	1.50	1.60	0.055	0.059	0.063
D1	1.40	1.50	1.60	0.055	0.059	0.063
P0	3.90	4.00	4.10	0.154	0.157	0.161
P1	7.90	8.00	8.10	0.311	0.315	0.319
P2	1.90	2.00	2.10	0.075	0.079	0.083
A0	6.85	6.90	7.00	0.270	0.271	0.276
B0	10.45	10.50	10.60	0.411	0.413	0.417
K0	2.68	2.78	2.88	0.105	0.109	0.113
T	0.24		0.27	0.009		0.011
t1	0.10			0.004		
10P0	39.80	40.00	40.20	1.567	1.575	1.583