

**Features**

- $V_{DS}(V) = 30V$
- $I_D = 50A$  ( $V_{GS} = 10V$ )
- $R_{DS(ON)} < 5m\Omega$  ( $V_{GS} = 10V$ )
- $R_{DS(ON)} < 7.3m\Omega$  ( $V_{GS} = 4.5V$ )

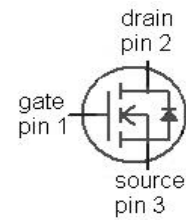
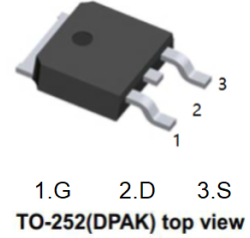

**Maximum ratings**, at  $T_j = 25\text{ °C}$ , unless otherwise specified

Parameter	Symbol	Conditions	Value	Unit
Continuous drain current	$I_D$	$V_{GS} = 10\text{ V}, T_C = 25\text{ °C}$	50	A
		$V_{GS} = 10\text{ V}, T_C = 100\text{ °C}$	50	
		$V_{GS} = 4.5\text{ V}, T_C = 25\text{ °C}$	50	
		$V_{GS} = 4.5\text{ V}, T_C = 100\text{ °C}$	50	
Pulsed drain current <sup>2)</sup>	$I_{D,pulse}$	$T_C = 25\text{ °C}$	350	
Avalanche current, single pulse <sup>3)</sup>	$I_{AS}$	$T_C = 25\text{ °C}$	50	
Avalanche energy, single pulse	$E_{AS}$	$I_D = 35\text{ A}, R_{GS} = 25\text{ }\Omega$	60	mJ
Reverse diode $dv/dt$	$dv/dt$	$I_D = 50\text{ A}, V_{DS} = 24\text{ V}, di/dt = 200\text{ A}/\mu\text{s}, T_{j,max} = 175\text{ °C}$	6	kV/ $\mu\text{s}$
Gate source voltage	$V_{GS}$		$\pm 20$	V

**Maximum ratings**, at  $T_j=25\text{ °C}$ , unless otherwise specified

Parameter	Symbol	Conditions	Value			Unit
Power dissipation	$P_{tot}$	$T_C=25\text{ °C}$	68			W
Operating and storage temperature	$T_j, T_{stg}$		-55 ... 175			°C
IEC climatic category; DIN IEC 68-1			55/175/56			
Parameter	Symbol	Conditions	Values			Unit
			min.	typ.	max.	
Thermal resistance, junction - case	$R_{thJC}$				2.2	K/W
SMD version, device on PCB	$R_{thJA}$	minimal footprint			75	
		6 cm <sup>2</sup> cooling area <sup>4)</sup>			50	
Drain-source breakdown voltage	$V_{(BR)DSS}$	$V_{GS}=0\text{ V}, I_D=1\text{ mA}$	30			V
Gate threshold voltage	$V_{GS(th)}$	$V_{DS}=V_{GS}, I_D=250\text{ }\mu\text{A}$	1		2.2	
Zero gate voltage drain current	$I_{DSS}$	$V_{DS}=30\text{ V}, V_{GS}=0\text{ V}, T_j=25\text{ °C}$		0.1	1	$\mu\text{A}$
		$V_{DS}=30\text{ V}, V_{GS}=0\text{ V}, T_j=125\text{ °C}$		10	100	
Gate-source leakage current	$I_{GSS}$	$V_{GS}=20\text{ V}, V_{DS}=0\text{ V}$		10	100	nA
Drain-source on-state resistance <sup>5)</sup>	$R_{DS(on)}$	$V_{GS}=4.5\text{ V}, I_D=30\text{ A}$		5.8	7.3	m $\Omega$
		$V_{GS}=10\text{ V}, I_D=30\text{ A}$		4.2	5	
Gate resistance	$R_G$			1.5		$\Omega$
Transconductance	$g_{fs}$	$ V_{DS} >2 I_D R_{DS(on)max}, I_D=30\text{ A}$	38	77		S

<sup>1)</sup> See figure 3 for more detailed information

<sup>2)</sup> See figure 13 for more detailed information

<sup>3)</sup> Device on 40 mm x 40 mm x 1.5 mm epoxy PCB FR4 with 6 cm<sup>2</sup> (one layer, 70  $\mu\text{m}$  thick) copper area for drain connection. PCB is vertical in still air.

<sup>4)</sup> Measured from drain tab to source pin

**Dynamic characteristics**

Parameter	Symbol	Conditions	Values			Unit
			min.	typ.	max.	
Input capacitance	$C_{iss}$	$V_{GS}=0\text{ V}, V_{DS}=15\text{ V},$ $f=1\text{ MHz}$		2400	3200	pF
Output capacitance	$C_{oss}$			920	1200	
Reverse transfer capacitance	$C_{rss}$			49		
Turn-on delay time	$t_{d(on)}$	$V_{DD}=15\text{ V}, V_{GS}=10\text{ V},$ $I_D=30\text{ A}, R_{G,ext}=1.6\ \Omega$		6.7		ns
Rise time	$t_r$			13		
Turn-off delay time	$t_{d(off)}$			25		
Fall time	$t_f$			3.8		
Gate to source charge	$Q_{gs}$	$V_{DD}=15\text{ V}, I_D=30\text{ A},$ $V_{GS}=0\text{ to }4.5\text{ V}$		7.4		nC
Gate charge at threshold	$Q_{g(th)}$			3.8		
Gate to drain charge	$Q_{gd}$			3.5		
Switching charge	$Q_{sw}$			7.1		
Gate charge total	$Q_g$			15	20	
Gate plateau voltage	$V_{plateau}$			3.1		
Gate charge total	$Q_g$	$V_{DD}=15\text{ V}, I_D=30\text{ A},$ $V_{GS}=0\text{ to }10\text{ V}$		31		nC
Gate charge total, sync. FET	$Q_{g(sync)}$	$V_{DS}=0.1\text{ V},$ $V_{GS}=0\text{ to }4.5\text{ V}$		13	17	
Output charge	$Q_{oss}$	$V_{DD}=15\text{ V}, V_{GS}=0\text{ V}$		24		
Diode continuous forward current	$I_S$	$T_C=25\text{ }^\circ\text{C}$			50	A
Diode pulse current	$I_{S,pulse}$				350	
Diode forward voltage	$V_{SD}$	$V_{GS}=0\text{ V}, I_F=30\text{ A},$ $T_j=25\text{ }^\circ\text{C}$		0.86	1.1	V
Reverse recovery charge	$Q_{rr}$	$V_R=15\text{ V}, I_F=I_S,$ $di_F/dt=400\text{ A}/\mu\text{s}$			15	nC

<sup>6)</sup> See figure 16 for gate charge parameter definition

**1 Power dissipation**

$P_{tot}=f(T_C)$

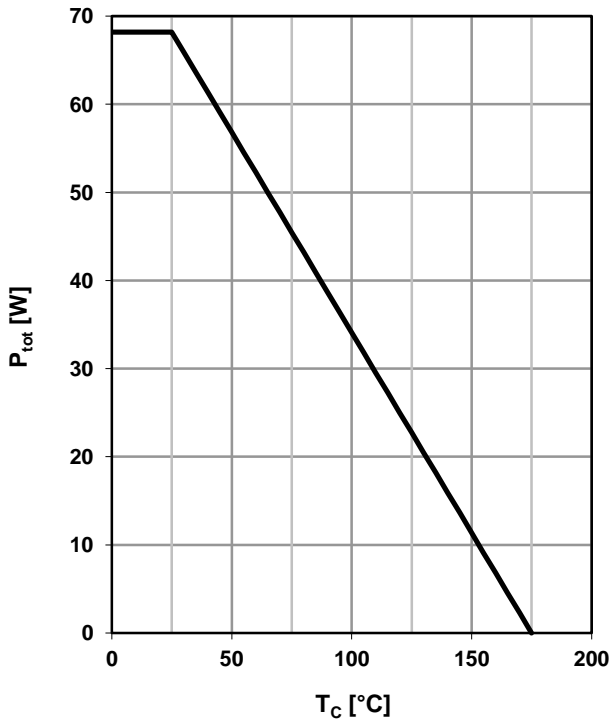

**2 Drain current**

$I_D=f(T_C); V_{GS} \geq 10V$

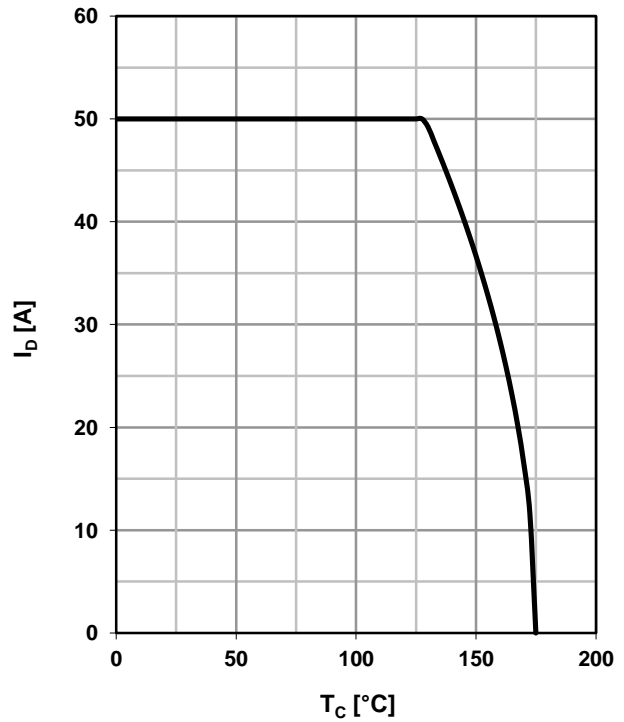

**3 Safe operating area**

$I_D=f(V_{DS}); T_C=25^\circ C; D=0$

parameter:  $t_p$

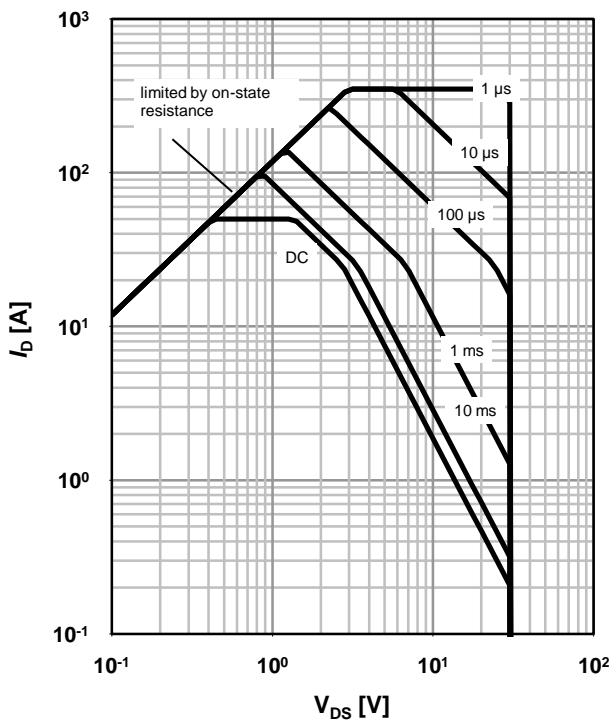

**4 Max. transient thermal impedance**

$Z_{thJC}=f(t_p)$

parameter:  $D=t_p/T$

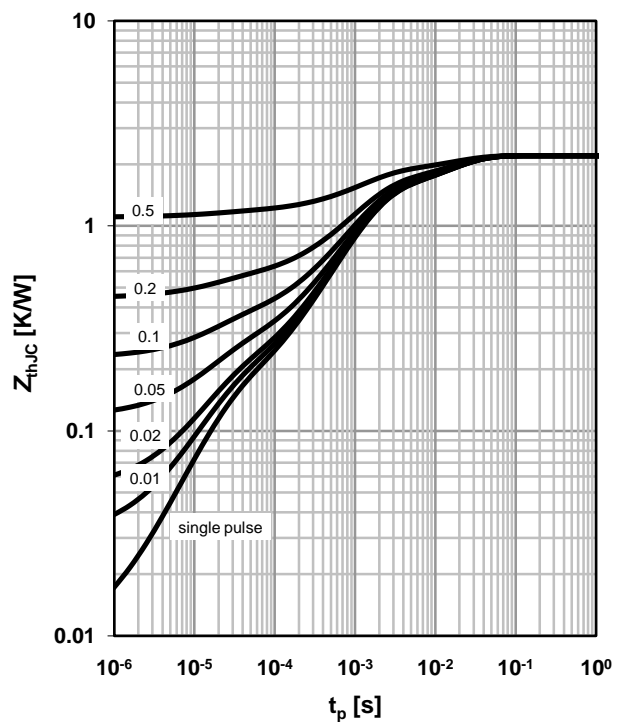

**5 Typ. output characteristics**

$I_D = f(V_{DS}); T_j = 25\text{ °C}$

parameter:  $V_{GS}$

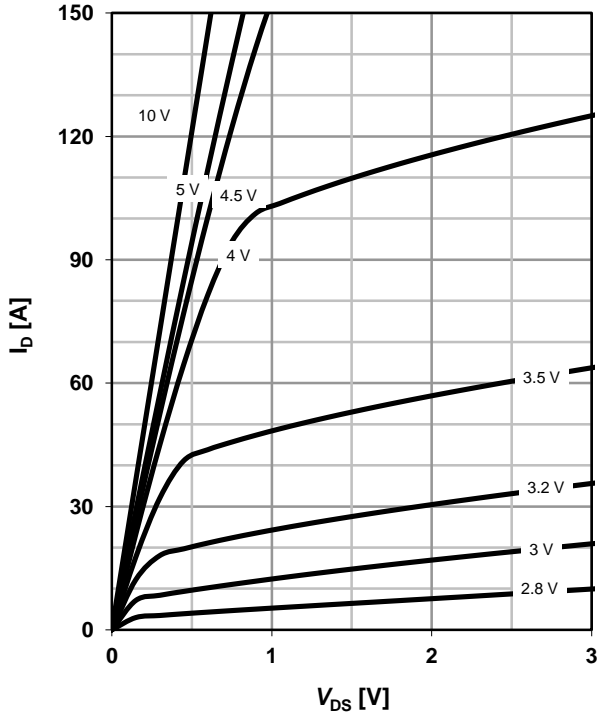

**6 Typ. drain-source on resistance**

$R_{DS(on)} = f(I_D); T_j = 25\text{ °C}$

parameter:  $V_{GS}$

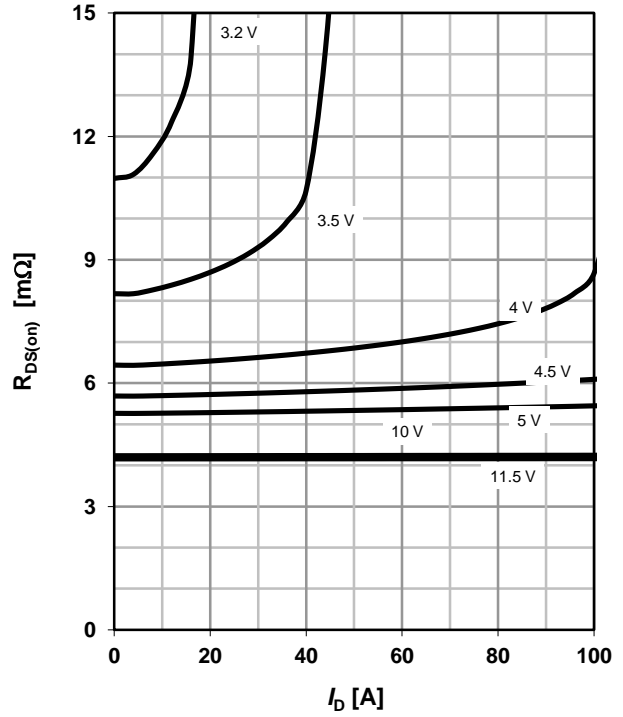

**7 Typ. transfer characteristics**

$I_D = f(V_{GS}); |V_{DS}| > 2|I_D|R_{DS(on)max}$

parameter:  $T_j$

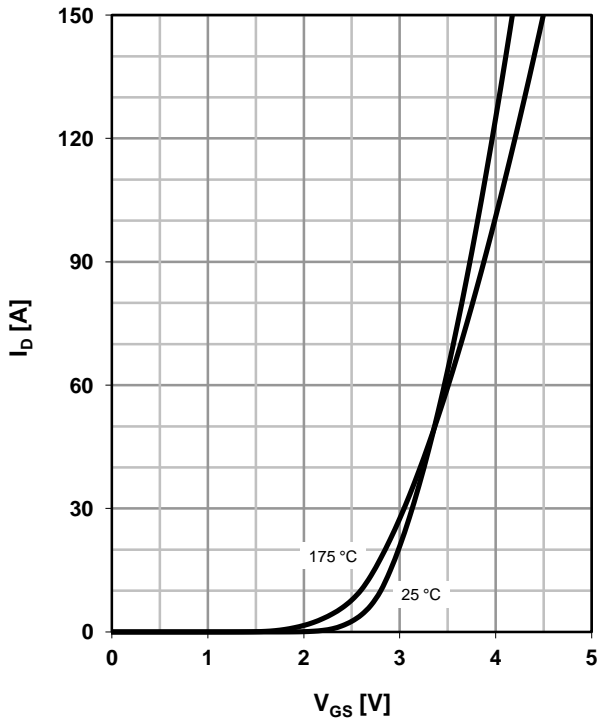

**8 Typ. forward transconductance**

$g_{fs} = f(I_D); T_j = 25\text{ °C}$

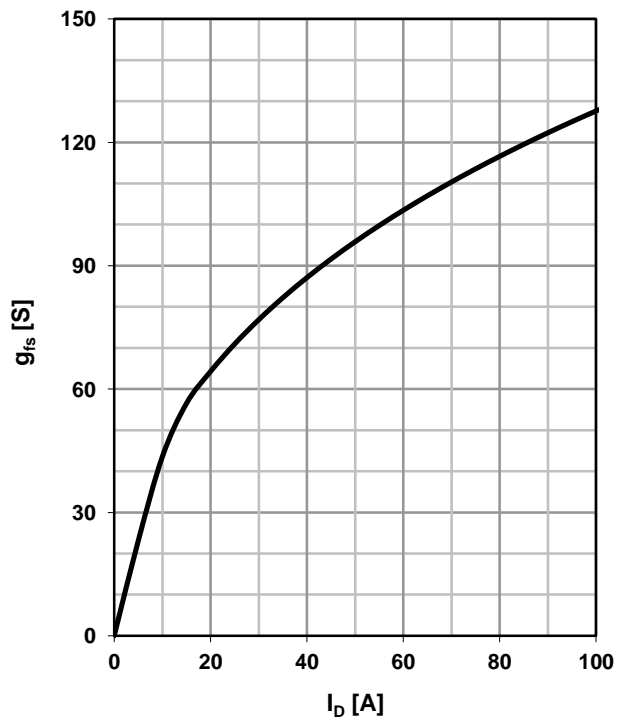

**9 Drain-source on-state resistance**

$R_{DS(on)}=f(T_j); I_D=30\text{ A}; V_{GS}=10\text{ V}$

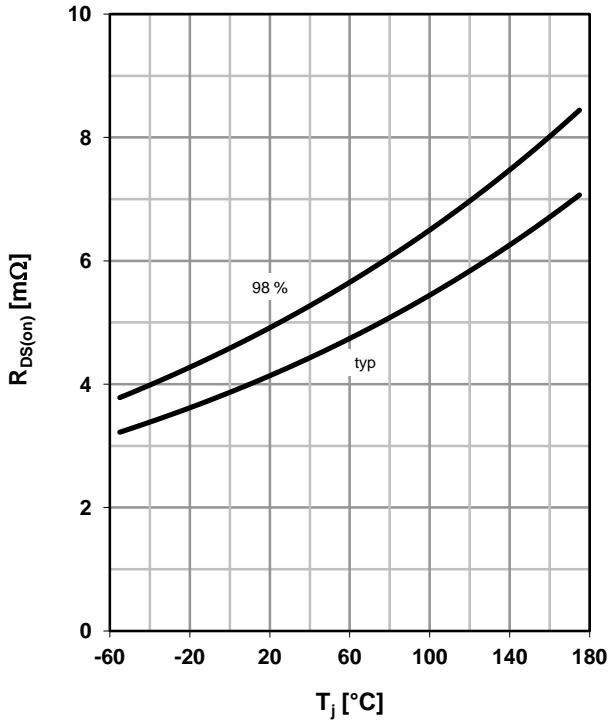

**10 Typ. gate threshold voltage**

$V_{GS(th)}=f(T_j); V_{GS}=V_{DS}; I_D=250\ \mu\text{A}$

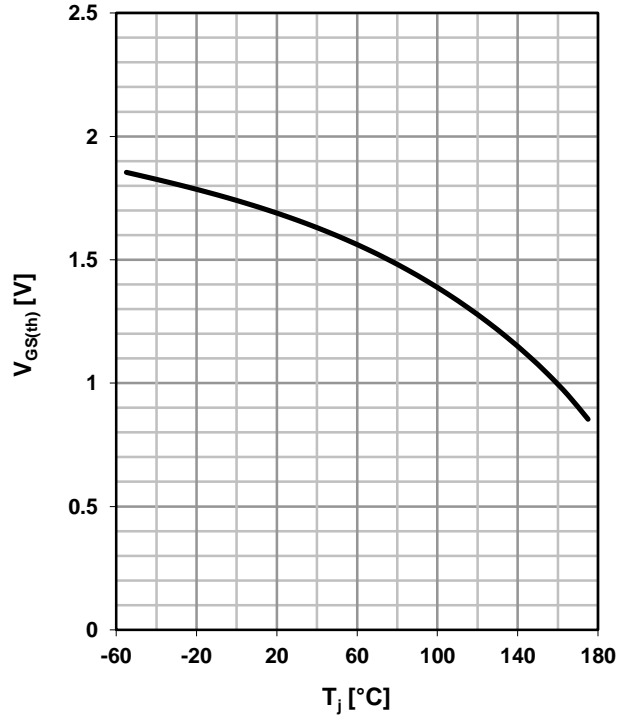

**11 Typ. capacitances**

$C=f(V_{DS}); V_{GS}=0\text{ V}; f=1\text{ MHz}$

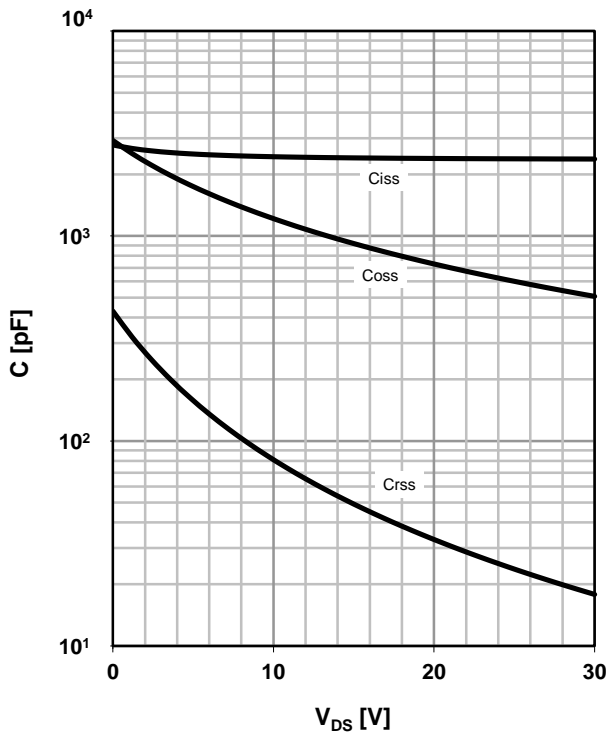

**12 Forward characteristics of reverse diode**

$I_F=f(V_{SD})$

parameter:  $T_j$

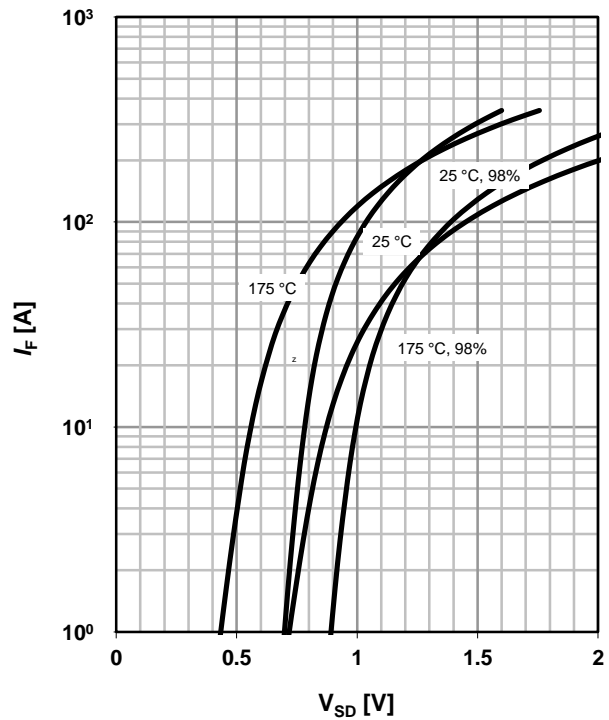

**13 Avalanche characteristics**

$I_{AS}=f(t_{AV}); R_{GS}=25\ \Omega$

parameter:  $T_{j(\text{start})}$

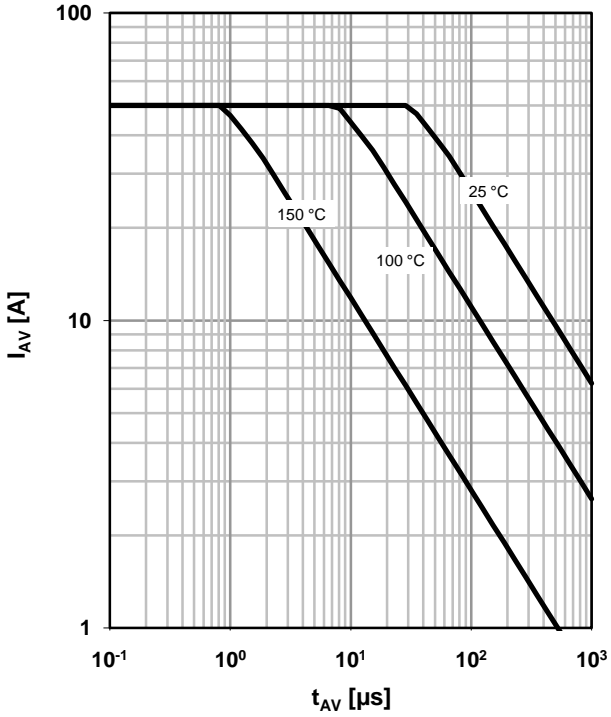

**14 Typ. gate charge**

$V_{GS}=f(Q_{\text{gate}}); I_D=30\ \text{A pulsed}$

parameter:  $V_{DD}$

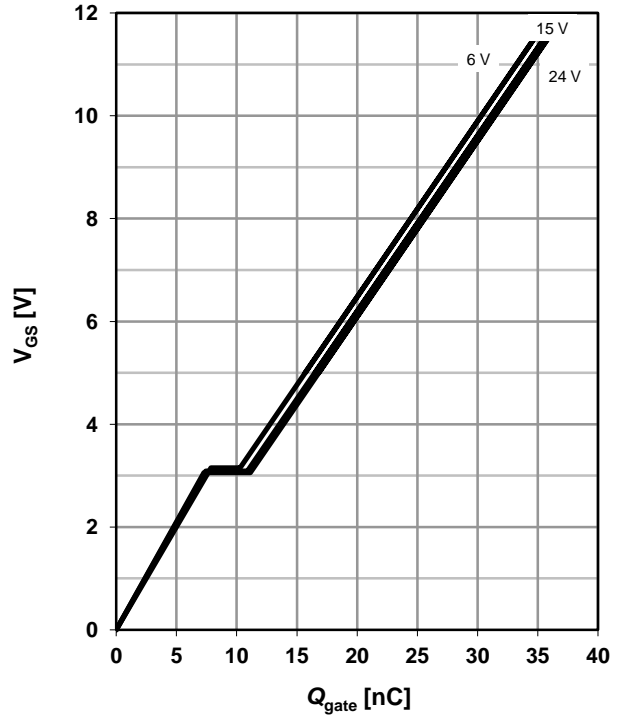

**15 Drain-source breakdown voltage**

$V_{BR(DSS)}=f(T_j); I_D=1\ \text{mA}$

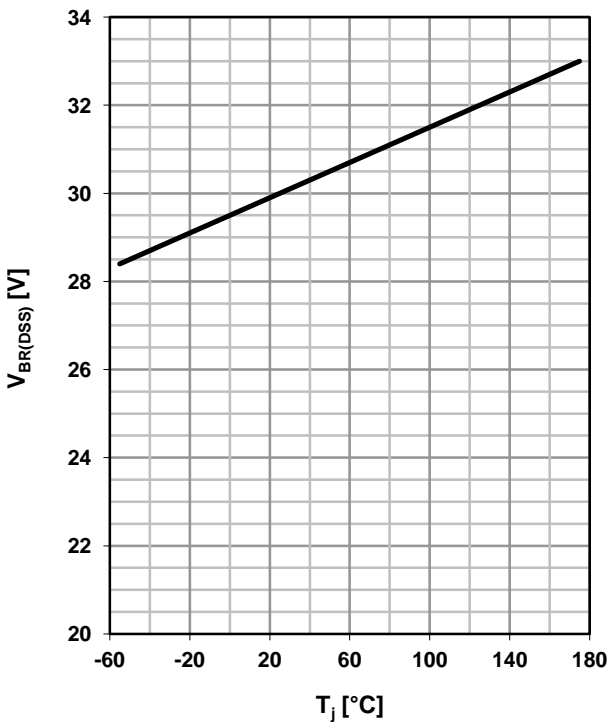

**16 Gate charge waveforms**

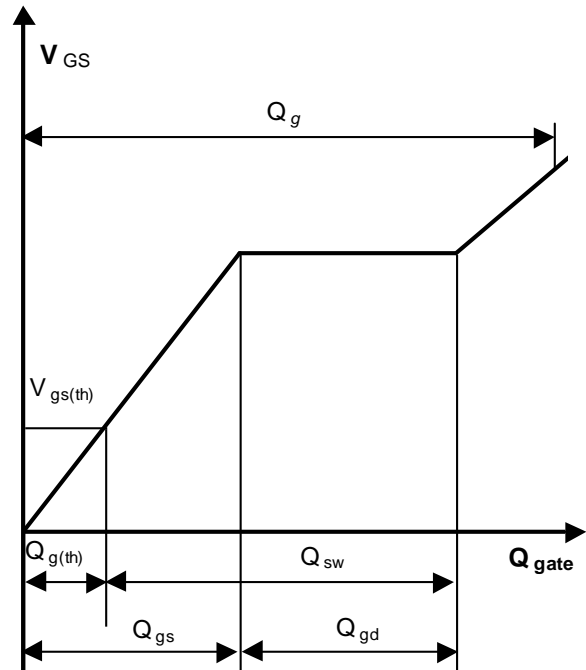

Package Mechanical Data TO-252

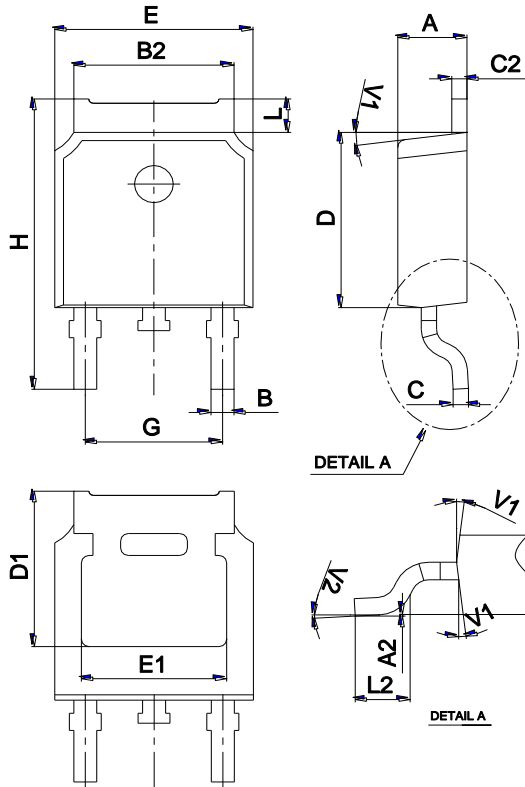

Ref.	Dimensions					
	Millimeters			Inches		
	Min.	Typ.	Max.	Min.	Typ.	Max.
A	2.10		2.50	0.083		0.098
A2	0		0.10	0		0.004
B	0.66		0.86	0.026		0.034
B2	5.18		5.48	0.202		0.216
C	0.40		0.60	0.016		0.024
C2	0.44		0.58	0.017		0.023
D	5.90		6.30	0.232		0.248
D1	5.30REF			0.209REF		
E	6.40		6.80	0.252		0.268
E1	4.63			0.182		
G	4.47		4.67	0.176		0.184
H	9.50		10.70	0.374		0.421
L	1.09		1.21	0.043		0.048
L2	1.35		1.65	0.053		0.065
V1		7°			7°	
V2		0°	6°	0°		6°

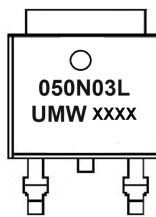

Ordering information

Order code	Package	Baseqty	Deliverymode
UMW IPD050N03LGATMA1	TO-252	2500	Tape and reel