



## WGP4N60SE

## Features:

- Low Intrinsic Capacitances.
- Excellent Switching Characteristics.
- Extended Safe Operating Area.
- Unrivalled Gate Charge :Qg=14nC (Typ.).
- BVDSS=600 V, I<sub>D</sub>=4A
- R<sub>DS(on)</sub> : 2.50Ω (Max) @V<sub>G</sub>=10V
- 100% Avalanche Tested

TO-220

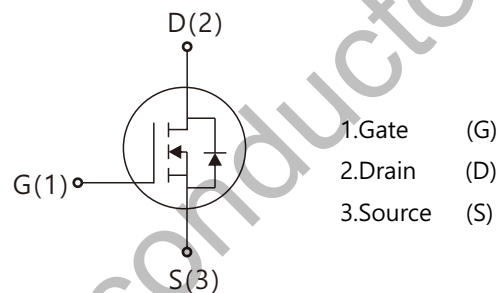
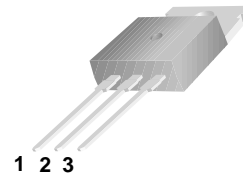

## Absolute Maximum Ratings (Ta=25°C unless other wise noted)

Symbol	Parameter	Value	Unit
V <sub>DSS</sub>	Drain-Source Voltage	600	V
I <sub>D</sub>	Drain Current	T <sub>j</sub> =25°C	4.0
		T <sub>j</sub> =100°C	2.7
V <sub>GS(TH)</sub>	Gate Threshold Voltage	30	V
E <sub>AS</sub>	Single Pulse Avalanche Energy (note1)	120	mJ
I <sub>AR</sub>	Avalanche Current (note2)	4.0	A
P <sub>D</sub>	Power Dissipation (T <sub>j</sub> =25 °C )	50	W
T <sub>j</sub>	Junction Temperature(Max)	150	°C
T <sub>stg</sub>	Storage Temperature	-55~+150	°C
TL	Maximum lead temperature for soldering purpose,1/8' from case for 5 seconds	300	°C

## Thermal Characteristics

Symbol	Parameter	Typ.	Max.	Unit
R <sub>θJC</sub>	Thermal Resistance,Junction to Case	-	2.4	°C/W
R <sub>θJA</sub>	Thermal Resistance,Junction to Ambient		62.5	°C/W

## Electrical Characteristics (Ta=25°C unless otherwise noted)

Symbol	Parameter	Test Condition	Min.	Typ.	Max.	Unit
Off Characteristics						
BV <sub>DSS</sub>	Drain-Source Breakdown Voltage	I <sub>D</sub> =250 μA, V <sub>GS</sub> =0	600	-	-	V
ΔBV <sub>DSS</sub> /ΔT <sub>J</sub>	Breakdown Voltage Temperature Coefficient	I <sub>D</sub> =250 μA, Reference to 25°C	-	0.67	-	V/°C
I <sub>DSS</sub>	Zero Gate Voltage Drain Current	V <sub>DS</sub> =650V, V <sub>GS</sub> =0V	-	-	10	μA
		V <sub>DS</sub> =520V, T <sub>J</sub> =125°C	-	-	100	
I <sub>GSSF</sub>	Gate-body leakage Current, Forward	V <sub>GS</sub> =+30V, V <sub>DS</sub> =0V	-	-	100	nA
I <sub>GSSR</sub>	Gate-body leakage Current, Reverse	V <sub>GS</sub> =-30V, V <sub>DS</sub> =0V	-	-	-100	
On Characteristics						
V <sub>GS(TH)</sub>	Gate Threshold Voltage	I <sub>D</sub> =250μA, V <sub>DS</sub> =V <sub>GS</sub>	2	-	4	V
R <sub>DS(ON)</sub>	Static Drain-Source On-Resistance	I <sub>D</sub> =2.0A, V <sub>GS</sub> =10V	-	-	2.5	Ω
Dynamic Characteristics						
C <sub>iss</sub>	Input Capacitance	V <sub>DS</sub> =25V, V <sub>GS</sub> =0, f=1.0MHz	-	560	-	pF
C <sub>oss</sub>	Output Capacitance		-	48	-	
C <sub>rss</sub>	Reverse Transfer Capacitance		-	5.4	-	
Switching Characteristics						
T <sub>d(on)</sub>	Turn-On Delay Time	V <sub>DD</sub> =325V, I <sub>D</sub> =4A R <sub>G</sub> =25Ω (Note 3,4)	-	25	-	nS
T <sub>r</sub>	Turn-On Rise Time		-	45	-	
T <sub>d(off)</sub>	Turn-Off Delay Time		-	25	-	
T <sub>f</sub>	Turn-Off Rise Time		-	35	-	
Q <sub>g</sub>	Total Gate Charge	V <sub>DS</sub> =520V, V <sub>GS</sub> =10V, I <sub>D</sub> =4A (Note3,4)	-	14.3	-	nC
Q <sub>gs</sub>	Gate-Source Charge		-	2.8	-	
Q <sub>gd</sub>	Gate-Drain Charge		-	4.5	-	
Drain-Source Diode Characteristics and Maximum Ratings						
I <sub>S</sub>	Max. Diode Forward Current	-	-	-	4	A
I <sub>SM</sub>	Max. Pulsed Forward Current	-	-	-	16	
V <sub>SD</sub>	Diode Forward Voltage	I <sub>D</sub> =4A	-	-	1.4	V
T <sub>rr</sub>	Reverse Recovery Time	I <sub>S</sub> =4A, V <sub>GS</sub> =0V diF/dt=100A/μs	-	393	-	nS
Q <sub>rr</sub>	Reverse Recovery Charge	(Note3)	-	1.5	-	μC

Notes : 1, L=0.5mH, I<sub>AS</sub>= 4A, V<sub>DD</sub>=50V, R<sub>G</sub>=25Ω, Starting T<sub>J</sub> =25°C

2, Repetitive Rating : Pulse width limited by maximum junction temperature

3, Pulse Test : Pulse Width ≤ 300μs, Duty Cycle ≤ 2%

4, Essentially Independent of Operating Temperature

Typical Characteristics

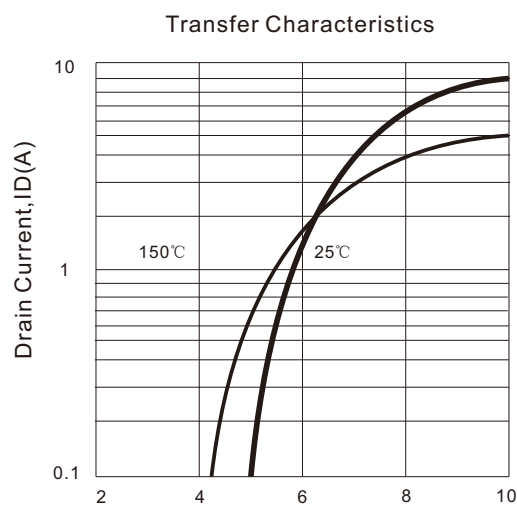
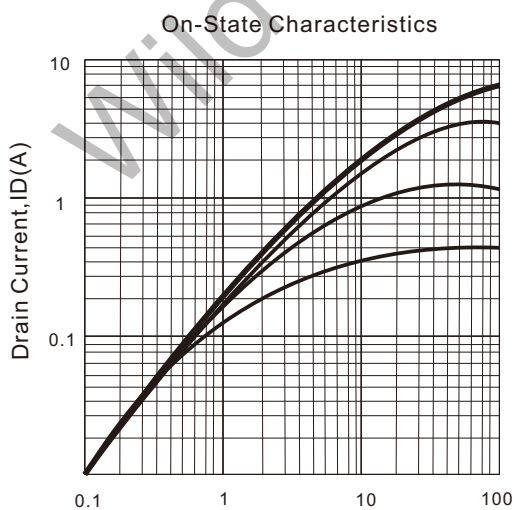
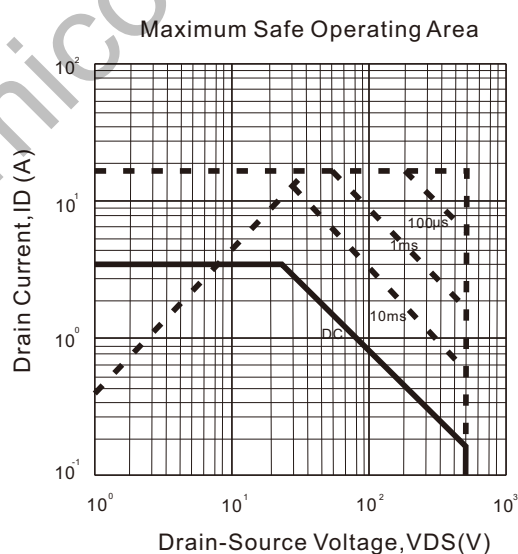
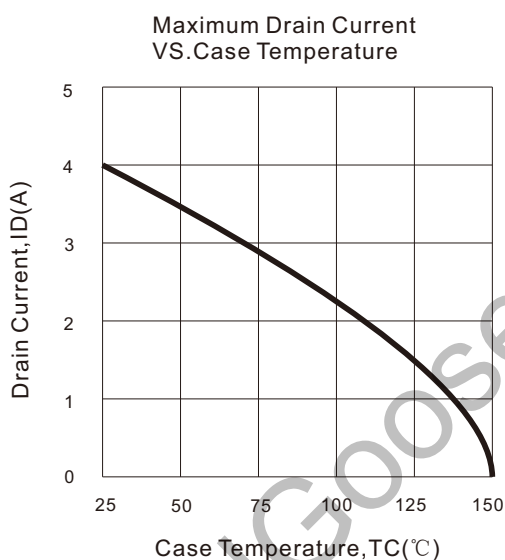
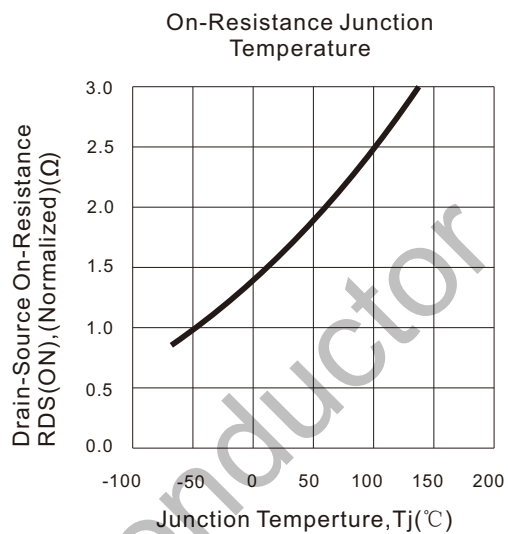
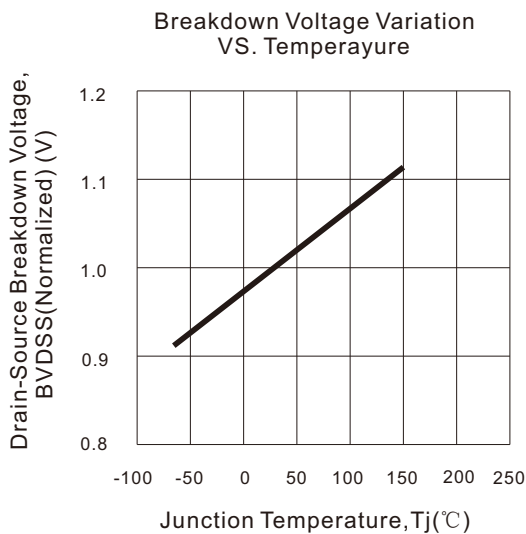

Typical Characteristics (Continued)

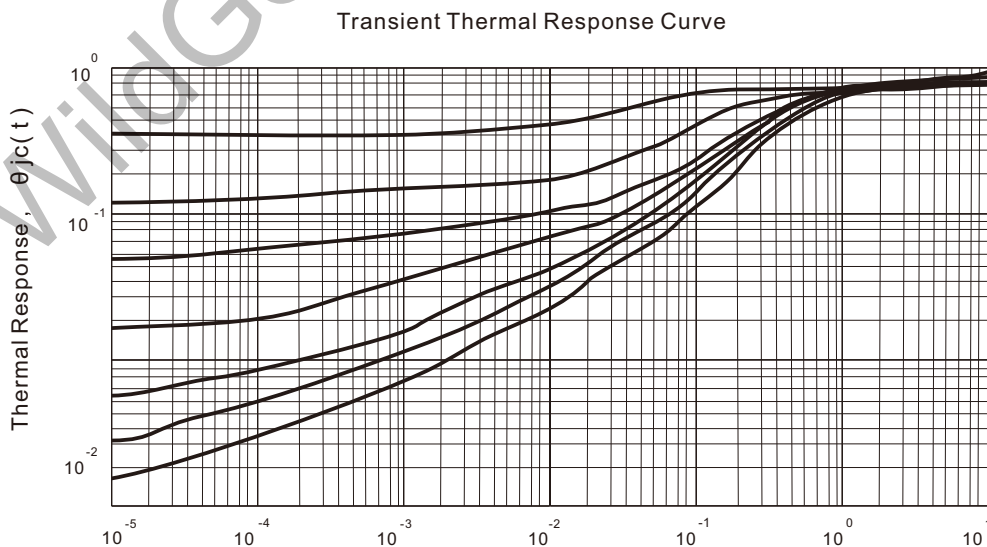
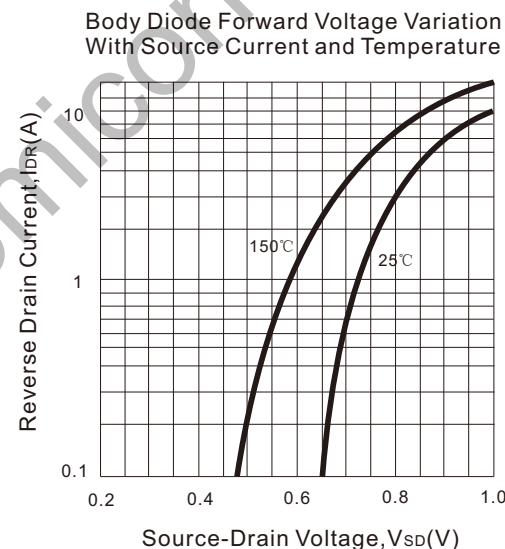
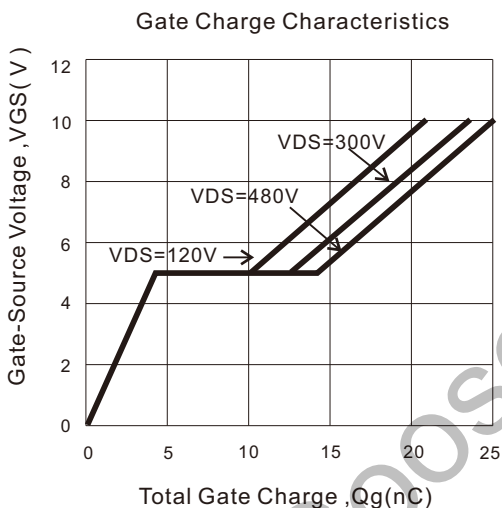
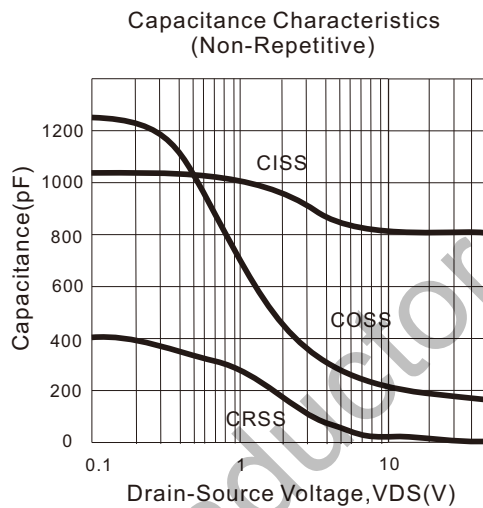
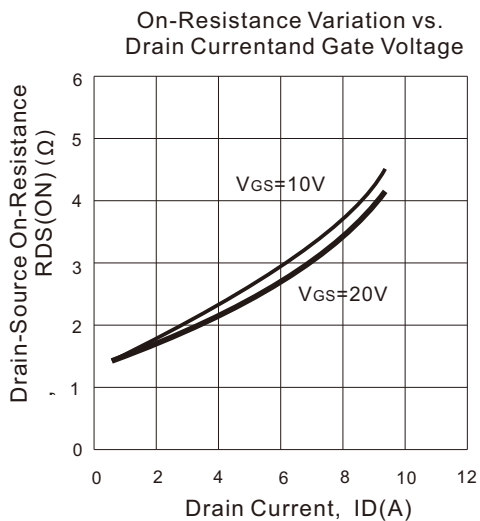

Gate Charge Test Circuit & Waveform

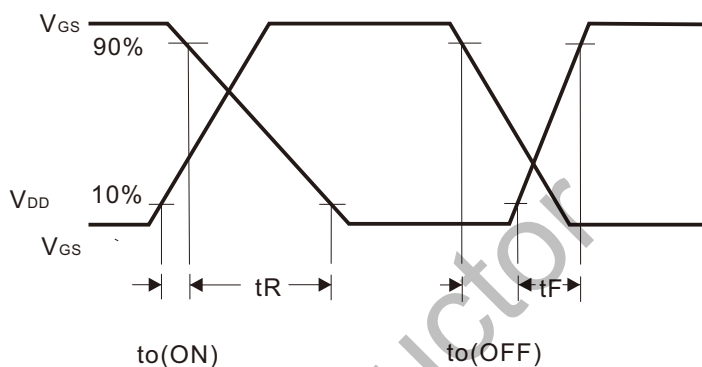
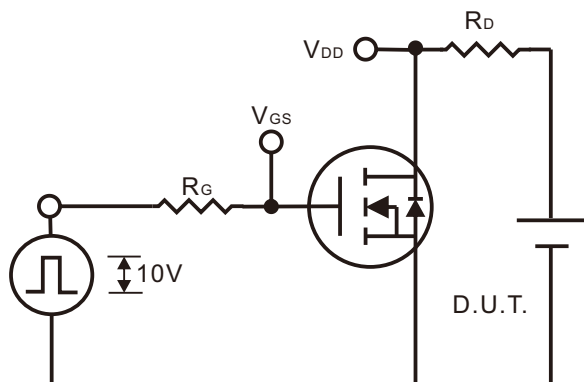

Switching Test Circuit

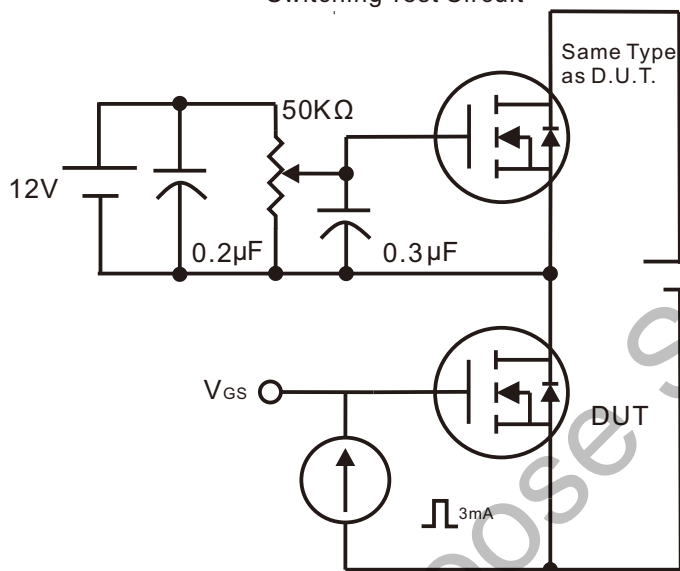

Switching Waveforms

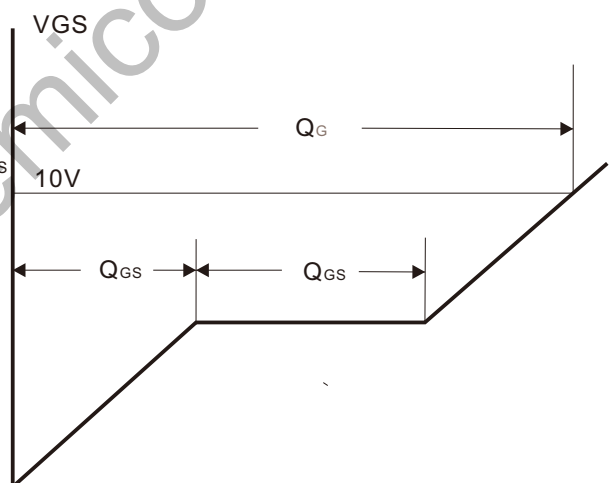

Gate Charge Test Circuit

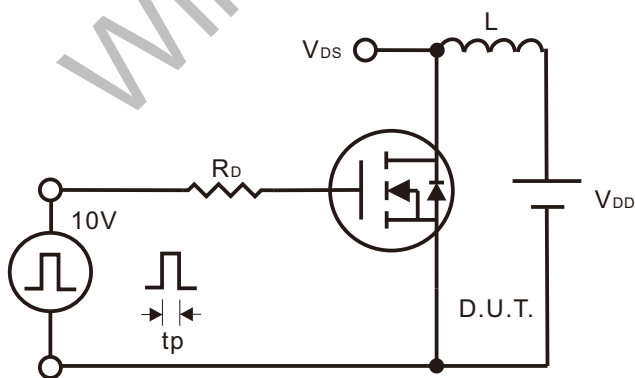

Gate Charge Waveform

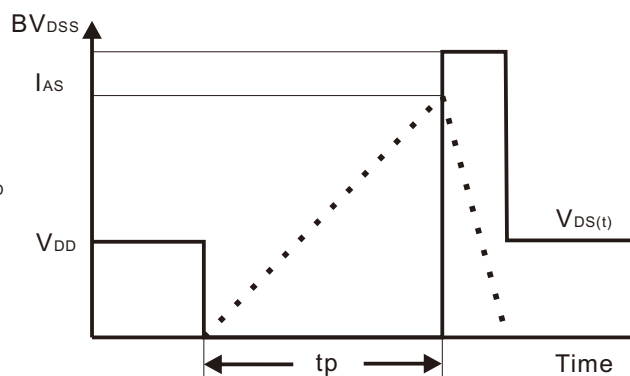

Unclamped Inductive Switching Test Circuit

Unclamped Inductive Switching Waveforms

Peak Diode Recovery dv/dt Test Circuit & Waveform

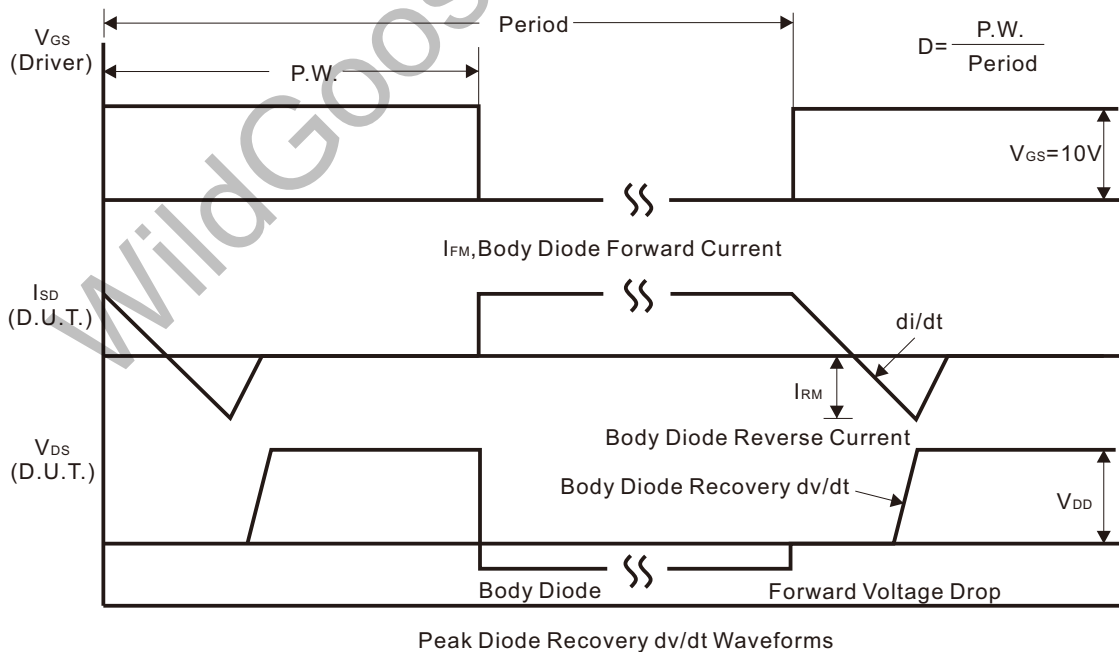
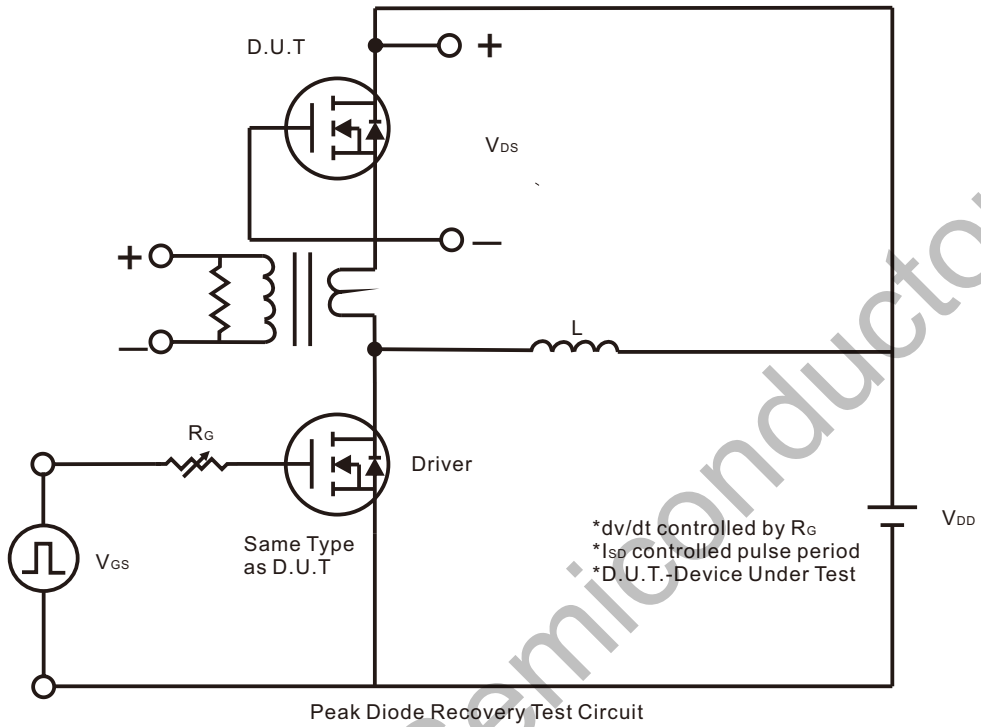

Package Dimension

TO-220

Unit: mm

