

# APPROVAL SHEET

Customer Name : \_\_\_\_\_  
Customer P/N : \_\_\_\_\_  
Frequency : 26.000000 MHz  
Aker Approved P/N : VTOF-026000-2-AL-01  
Aker MPN : VTOF-026000-2-AL-01  
Rev. : 1  
ISSUE DATE : Nov.15.2022

APPROVED	CHECKED	PREPARED
<i>Tim</i>		<i>Kika</i>
APPROVED BY CUSTOMER		

## AKER TECHNOLOGY CO., LTD.

ADDRESS : NO 11-3, Jianguo Rd., Tanzi Dist., Taichung City 427, Taiwan.

TEL : 886-4-25335978 FAX : 886-4-25336011

Web: [www.aker.com.tw](http://www.aker.com.tw)

**MSL:Level 1**  
**RoHS compliant**



## SMD Temperature compensated crystal oscillator

### 1. ELECTRICAL CHARACTERISTICS

■ Standard atmospheric conditions

Unless otherwise specified, the standard range of atmospheric conditions for making measurement and tests are as follow :

Ambient temperature : 25±5°C

Relative humidity : 40%~70%

If there is any doubt about the results, measurement shall be made within the following limits :

Ambient temperature : 25±3°C

Relative humidity : 40%~70%

■ AKER Model : VTOF-221

■ Cutting Mode : AT CUT

Parameters	Electrical Spec				Notes
	Min.	Typ.	Max.	Units.	
Nominal Frequency	26.000000			MHz	
Supply voltage	1.71	1.80	1.89	V	
Nominal Frequency Tolerance	-2.0	~	2.0	ppm	After 2 times reflow soldering
Frequency stability over temperature	-0.5	~	0.5	ppm	Between minimum and maximum frequency value over the specified temperature range.
Supply voltage stability	-0.2	~	0.2	ppm	
Load sensitivity	-0.2	~	0.2	ppm	±10% Load change
Load	10//10			KΩ//pF	
Temperature range	-40	~	85	°C	
Storage temperature range	-40	~	85	°C	
Current Consumption			2.0	mA	
Output Waveform	Clipped Sine Wave				
Output voltage level	0.8			Vpp	
VCTL	0.3	0.9	1.5	V	Positive slope(df/dv)
Pulling Range	±3	~	±5	ppm	
Vcon input impedance	500			KΩ	
Aging	-1.0	~	1.0	ppm	First Year
Typical SSB phase noise power density		-114		dBc/Hz	100Hz offset.
Typical SSB phase noise power density		-131		dBc/Hz	1KHz offset.
Typical SSB phase noise power density		-148		dBc/Hz	10KHz offset.

## 2 . VCTCXO TESTING CIRCUIT

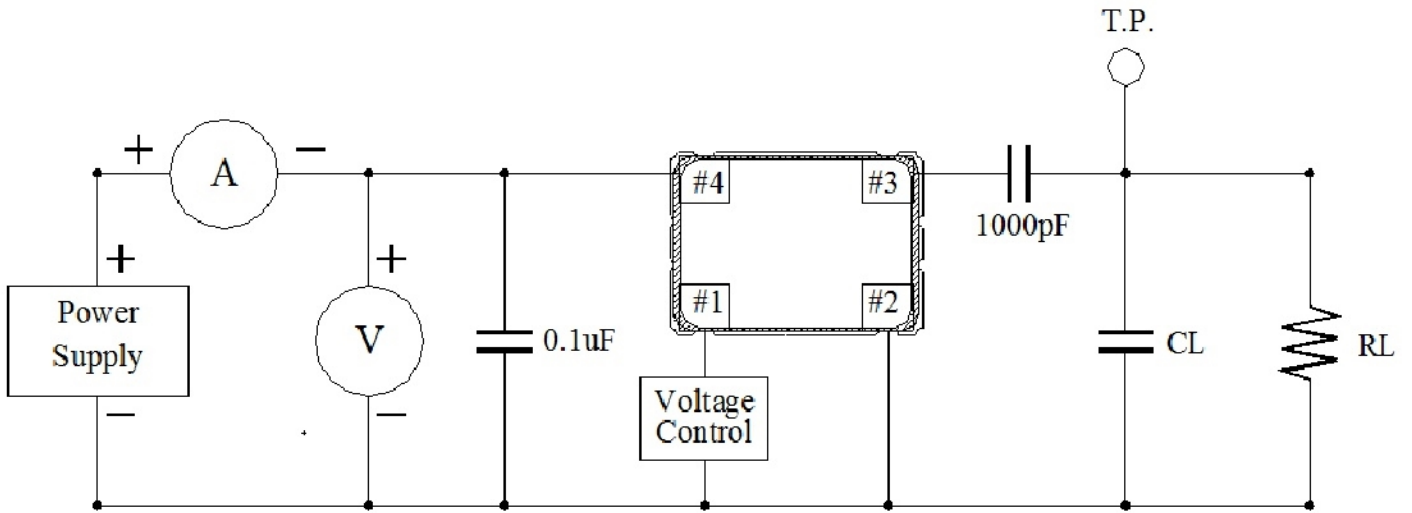

### 3. MARKING :

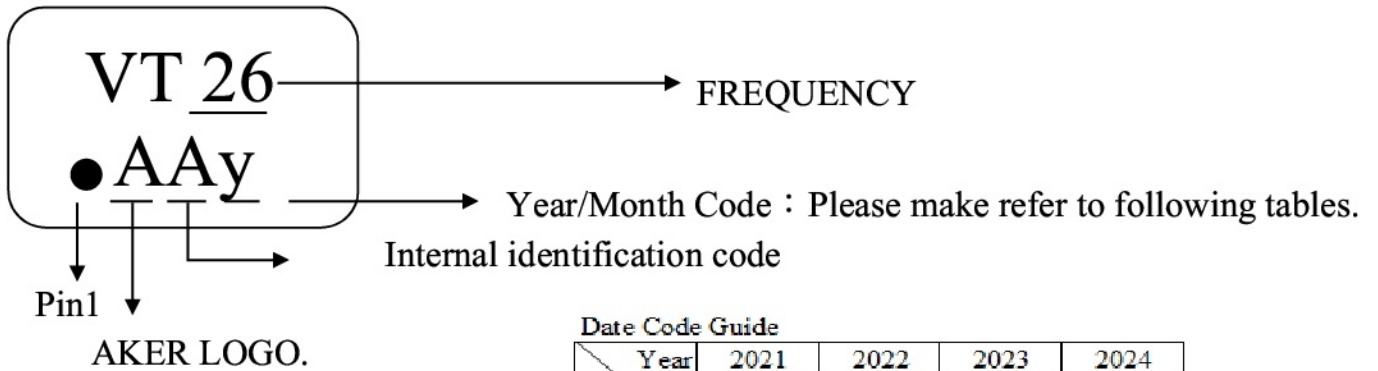

Date Code Guide

Year	2021	2022	2023	2024
	2025	2026	2027	2028
Month	(4N+1)	(4N+2)	(4N+3)	(4N+0)
JAN	a	n	A	N
FEB	b	p	B	P
Mar	c	q	C	Q
Apr	d	r	D	R
May	e	s	E	S
Jun	f	t	F	T
Jul	g	u	G	U
Aug	h	v	H	V
Sep	j	w	J	W
Oct	k	x	K	X
Nov	l	y	L	Y
Dec	m	z	M	Z

A cycle every four years

### 4. DIMENSION :

( Unit : mm )

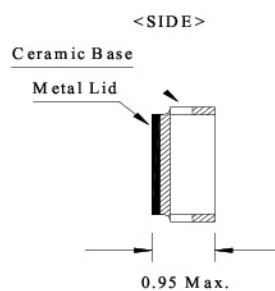
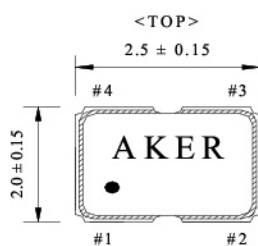

Pad	Function
#1	VCON
#2	GND
#3	Output
#4	Vdd

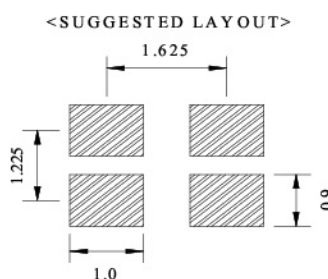
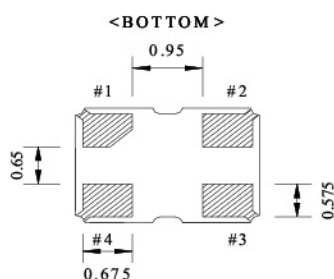

### 5. PACKING :

#### TAPE SPECIFICATION

( Unit : mm )

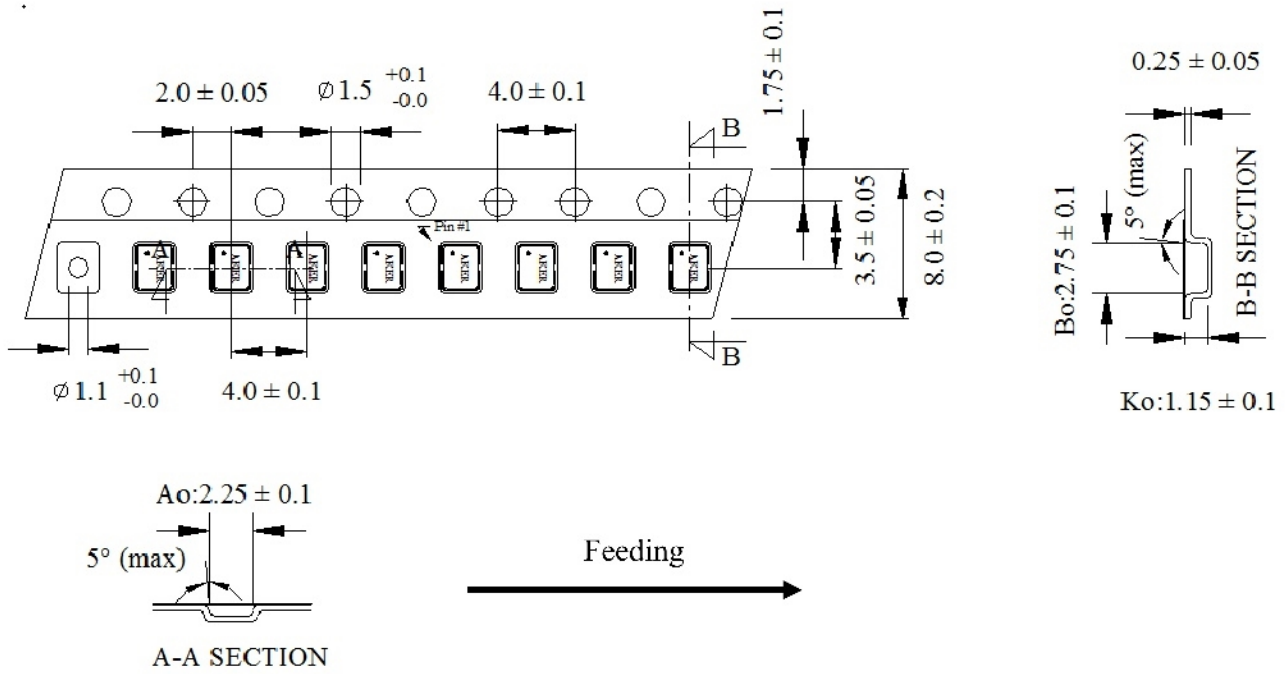

#### OUTLINE DIMENSION

( Unit : mm )

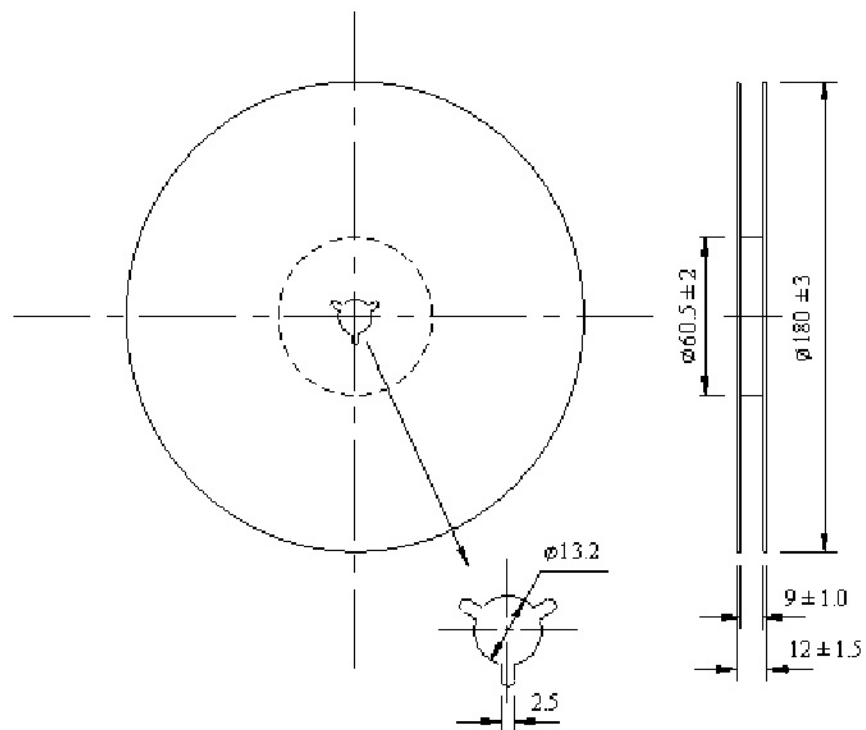

## 6. COVER TAPE ADHESION STRENGTH :

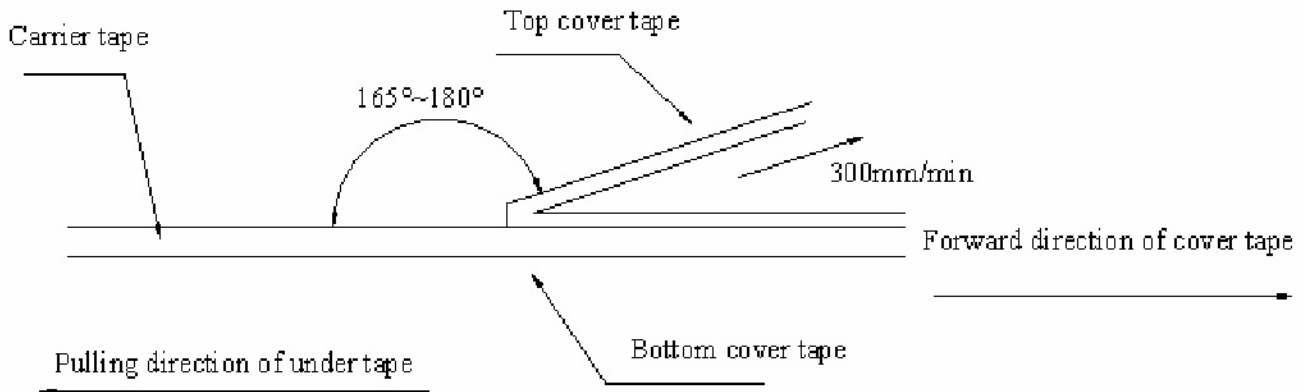

\*\*\* In the case, the cover tape is pulled off under the above conditions, the cover tape adhesion strength should be 10.2g~71.4g

Plastic tape: 10.2g~71.4g

(Cover tape adhesion strength)

## 7. SOLDERING REFLOW PROFILE

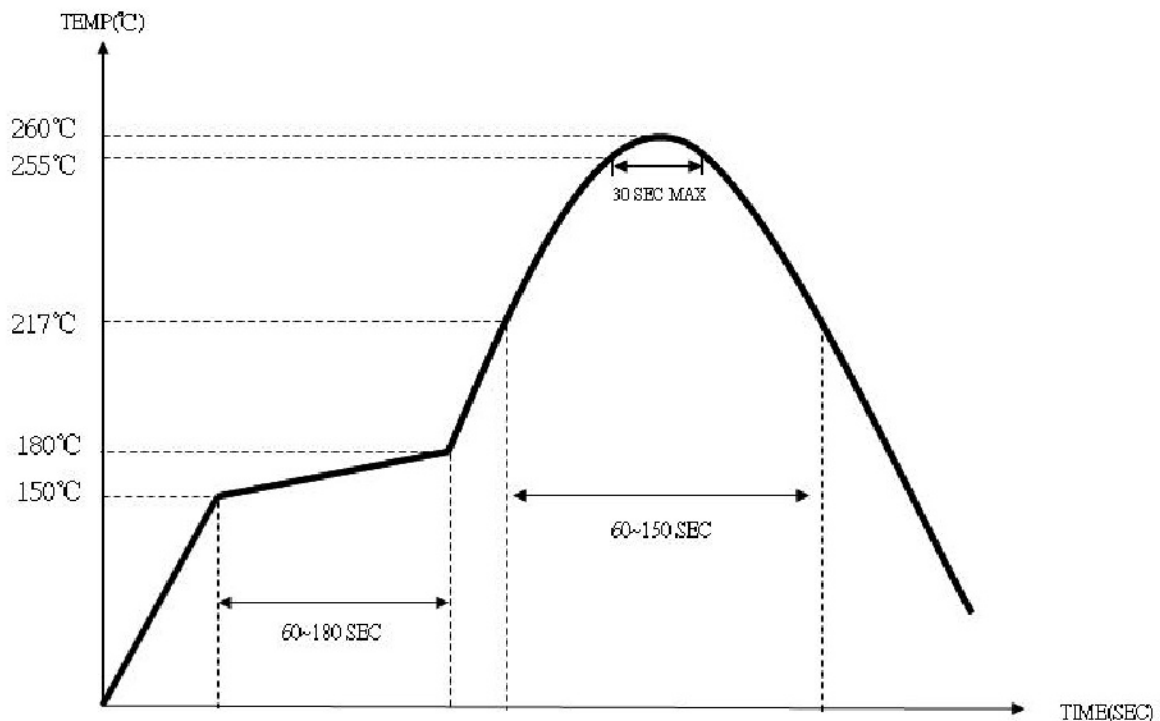

## 8 . PACKING

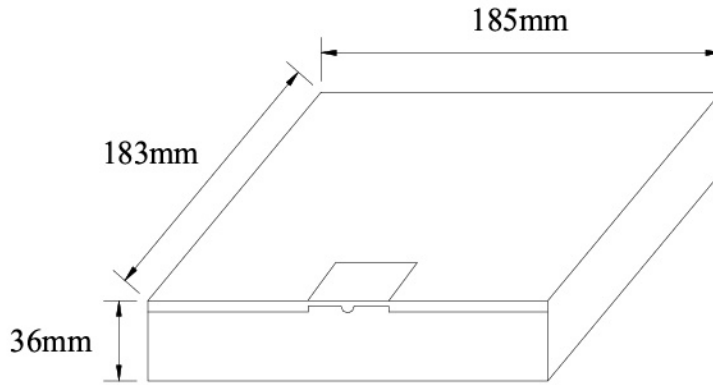

BOX = 3000 PCS / REEL(MAX)

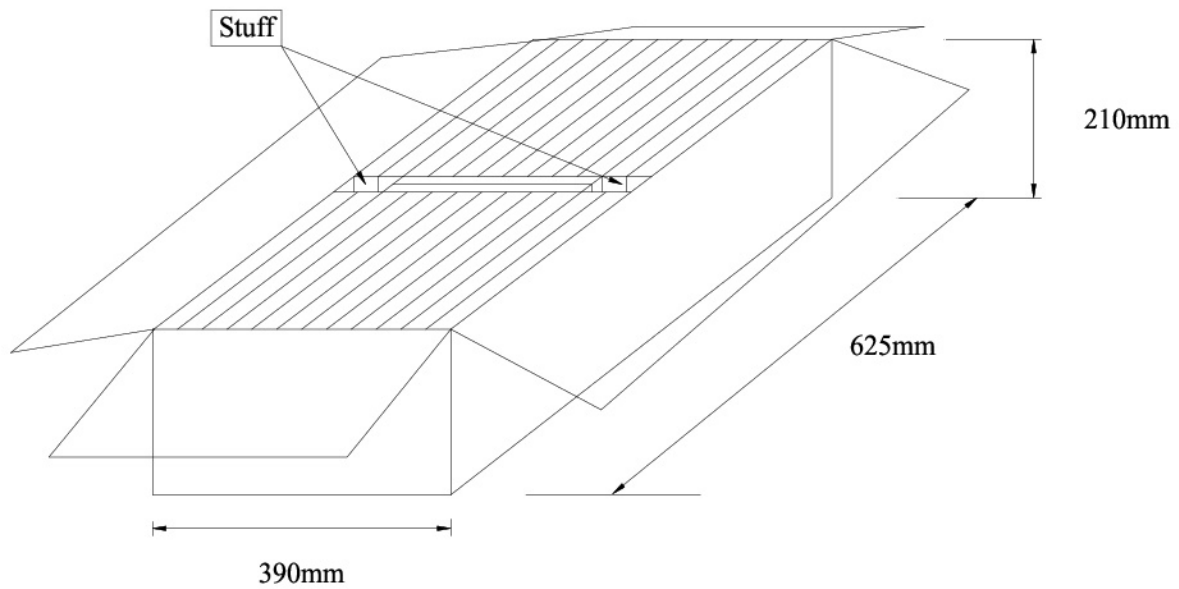

SMD product packs 32 BOX=The outside box packs (3000 PCS \* 32 BOX = 96000 PCS)(MAX)





Aker Approved P/N :	VTOF-026000-2-AL-01		
APPROVED :	Tin	SHEET : 8 of 8	
PREPARED :	Kiku	REV. : 1	
Confidential			

## 9 .RELIABILITY SPECIFICATION

### Mechanical Endurance

TEST ITEMS	TEST METHODS AND TEST CONDITION	PERFORMANCE
9.1 Temperature Cycling	-40±3°C/30min maximum~+85±3°C/30min maximum , 1000cycles	ΔF≤±2ppm
9.2 Operational Life	85°C±3°C , 1000hrs±12hrs Rated VDD applied.	ΔF≤±2ppm
9.3 Biased Humidity	85°C±5°C&85%±5%R.H. , 1000±12hrs Rated VDD applied.	ΔF≤±2ppm
9.4 Resistance To Soldering Heat Test	Reflow test 2 times.	ΔF≤±2ppm
9.5 High Temperature Exposure	85°C±3°C , 1000hrs±12hrs	ΔF≤±2ppm
9.6 Vibration Test	Freq.range: 10~2000Hz , Peak to peak amplitude:1.52mm Peak acceleration:5G (49m/s <sup>2</sup> ) , 3 direction(X, Y,Z) , 20min 12cycles each of 3 orientations.	ΔF≤±2ppm
9.7 Mechanical Shock	100G , 6mS , 3 times for each direction(X, Y, Z ) , 3 cycles	ΔF≤±2ppm
9.8 Physical Dimension	Verify physical dimensions to the applicable device detail specification.	
9.9 Solderability	260°C , Coated > 95%	
9.10 Board Flex	PCB=100*40(mm) , Bending=2 mm (min) , Duration=60+5/-0 sec	ΔF≤±2ppm
9.11 External Visual	Inspect device construction and marking.	
9.12 Terminal	A force of 17.7N for 60 seconds.	ΔF≤±2ppm

Strength