

ZX-QC-LT39293226

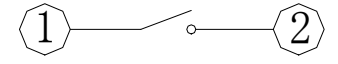

电路图

CIRCUIT DIAGRAM

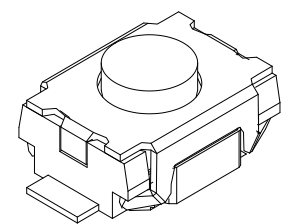
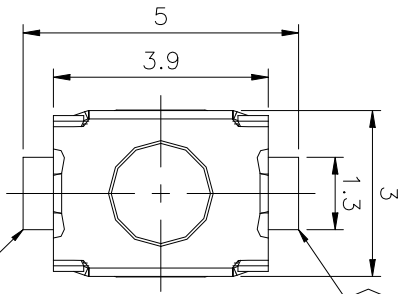
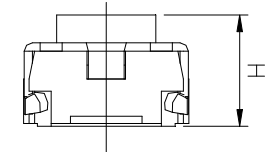
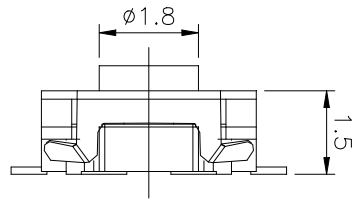
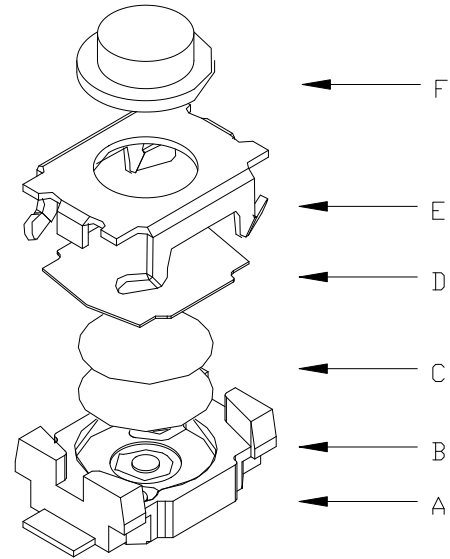
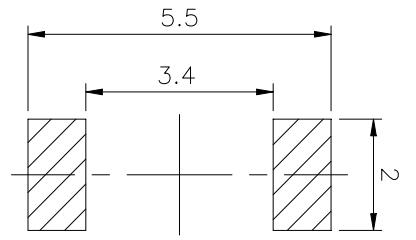

PCB. 焊接图

PCB. WELDING DRAWING

主要技术参数、性能

The Main Thchnology Performance

额定电流、电压 Rate voltage.current	50mA DC12V
接触电阻 Contact resistance	≤100mΩ
按力 Operating force	±50gf
行程 Travel	0.20±0.10mm
绝缘电阻 Insulated resistance	≥100MΩ
介电强度 Dielectric strength	≥250VAC/1min

F	按钮	LCP	1	黑色
E	盖板	不锈钢	1	清洗
D	防尘胶	聚酰亚胺	1	橙黄色
C	弹片	不锈钢	2	镀银
B	本体	LCP	1	黑色
A	卡件	磷铜	1	镀银
项目 ITEM	名称 DESCRIPTION	材质 MATERIAL	数量 QTY	表面处理/颜色 FINSH/COLOR

						第一视角 FIRST VIEW		名称/NAME: 3.9*2.93*2mm 立贴 轻触开关	
								型号/MODEL: BX-TS-26-392932T	
标记 SING	处数 FREQUENCY	更改文件号 REVISION	签名 APPROVED	日期 DATE	比例 SCALE	1:1	一般公差 GENERAL TOLERANCE		
设计 DESIGN					单位 UNIT	mm	≥0~2<	±0.15	
审核 CHECKED					重量 WEIGHT		≥2~5<	±0.25	
批准 APPROVED							≥5	±0.35	
								角度 ANGLE	±0.5°

