

With the English version following the Chinese version

描述

SIMx200 系列四通道模块基于 IMPINJ 新一代射频芯片 E710/E510/310 研发的高性能超高频 RFID 读写器模块。

输出功率从 5dBm 到 33dBm 可设置，标签读取距离大于 12 米（取决于天线增益和标签尺寸），且具有卓越的多标签盘存性能。

SIMx200 模块大功率、散热好、稳定可靠，采用先进的多标签识别算法，标签在移动或者静止状态下都能快速识别。

优越的抗干扰设计以及载波抵消功能，在各种环境下都能稳定工作。

多种配置模式，可广泛用于仓储，物流，产线，巡查等各种应用场合。



型号	灵敏度 @PER 10%	读标签速度 @96 bit EPC)
SIM7200	-85dbm	>1000
SIM5200	-78dbm	>600
SIM3200	-72dbm	>350

应用

- 固定式设备
- 发卡器
- 打印机
- 一体机

特点

- ARMv7-M 架构 32bit Cortex-M4 CPU，集成 FPU、MPU，DSP，最高工作主频 200MHz，512KByte 的 Flash
- 支持 UHF EPC Class1 Gen2/ISO 18000-6C
- 提供 Windows，Linux，Android SDK，以及基于 C，C#/.NET，JAVA 的 API
- 支持温度标签盘存，输出参数可包含标签返回信号的 RSSI，相位值
- 最大 33dBm 功率输出
- 优异的防冲突算法，高灵敏度，盘存标签最快速度大于 1000tag/s
- 多种盘存模式适应大多数应用
- 可设置 UART 串口通信波特率 9600bp~921600bps
- 两输入两输出 GPIO 口
- 北美、欧洲频段满功率 30dBm 功耗 5.75W

中国频段满功率 33dBm 功耗 7.5W

- 铝合金磨砂外壳，重 56 克，
尺寸 74.8mm x 48.5mm x 8.0mm
- 获得 SRRC, CE, FCC 等认证
- 符合 ROHS 要求

绝对最大额定值

参数	符号	最小值	典型值	最大值	单位
输入电压	VCC	-0.3		6	V
使能电压	VEN	-0.3		6	V
复位(NRST) GPI (IN1 IN2)输入低电压	VIL			0.6	V
复位(NRST) GPI (IN1 IN2)输入高电压	VIH	2.7			V
GPO (OUT1 OUT2)输出电流	IOH			15	mA
模块输出电流	AVCC			20	mA
ESD 保护电压 ¹	VESD	-2		2	kV
天线口 (ANT) 驻波比 ²	VSWR			8	/
工作温度 ³	TC	-30		75	°C
存储温度	TS	-55		100	°C



ESD 注意事项

在搬运、包装和测试设备时必须遵守适当的预防措施。

1. 天线端口测试条件 IEC61000-4-2 等级 1，接触放电；其他接口为 HBM 模型，接触放电。
2. 防止功放芯片损坏的最大允许驻波比，为了保证性能，建议天线驻波比小于 1.5。
3. 环境温度，温度最大限值与模块散热条件有关。

通用工作条件

参数	符号	最小值	典型值	最大值	单位
输入电压	VCC	4.5	5	5.5	V
					V
掉电电压	VEN			0.4	V
使能电压		1.5			V
复位(NRST) GPI (IN1 IN2) 输入低电压	VIL			0.3	V
复位(NRST) GPI (IN1 IN2) 输入高电压	VIH	3			V
GPO (OUT1 OUT2) 输出电流	IOH		10		mA
模块输出电流	AVCC		10		mA
天线口 (ANT) 驻波比 ¹	VSWR			2.5	/
工作湿度 (未冷凝)	RH	5		95	%
工作温度	TC	-25		65	°C
存储温度	TS	-40		85	°C

通用电气参数

参数		条件	最小值	典型值	最大值	单位	
频率	频率范围 ¹		860		960	MHz	
	频率步进值 ²			250/500		KHz	
	频率误差	@25°C	-10		10	ppm	
输出	输出功率		5		33	dBm	
	功率步进			1		dB	
	输出功率精度	5dBm~33dBm	-1		1	dB	
	输出功率平坦度	5dBm~33dBm	-1		1	dB	
	邻道泄露比*	第 1 邻道			-45		dB
		第 2 邻道			-65		dB
	20dB 占用带宽*	RF_MODE 7			110		KHz
		RF_MODE 11			215		KHz
	发射频谱模板* ³	裕量	2			dB	
	杂散发射（传导） ⁴	二次谐波			-55		dBm
三次谐波				-40		dBm	
测量	模块温度精度	-25°C~115°C ⁵	-4		4	°C	
	标签 RSSI 测试精度	@-60dBm	-3		3	dB	
	标签相位测试精度	@-60dBm	-5		5	degrees	
	负载回波损耗测试精度	RL>18dB 接衰减器	-4		4	dB	
UART	默认波特率	数据格式：8N1		115200		bps	
	可设置波特率		9600		921600	bps	
功耗	掉电模式			0.00025		W	
	低功耗待机模式			0.1		W	
	普通待机模式			0.8		W	
	工作模式 ⁶	北美、欧洲 @30dBm			5.75		W
中国@33dBm				7.5		W	

1. 频率区域选择频段，不能同时支持多个频率区域。
2. 可通根据频率区域配置所需频率步进。
3. 参考《ETSI EN 302 208》 4.3.5 Transmitter spectrum masks。
4. 全频段条件下测试。
5. 当温度超过 90°C时，模块强制停止模块盘存，需要手动重新发送命令启动盘存。
6. 模块工作功耗会因负载天线匹配情况而有所变化。

标注 * 表示测试时采用盘存模式为 RF_MODE 7, 频谱仪设置 MAXHOLD。

空口模式参数与性能

RF_MODE ID	Forward Link Modulation	Tari (us)	BLF (KHz)	Reverse Link Modulation	Receive Sensitivity Minimum ¹ (dBm)			Read Rate ² (tags/s)
					E710	E510	E310	
11	PR-ASK	7.5	640	FMO	-63	N/A	N/A	>900
1	PR-ASK	7.5	640	Miller M=2	-69.3	-63.6	N/A	>650
15	PR-ASK	7.5	640	Miller M=4	-76	-70	N/A	>450
12	PR-ASK	15	320	Miller M=2	-75.1	-70.1	-62.1	>350
3	PR-ASK	20	320	Miller M=2	-75	-69.7	-62.2	>300
5	PR-ASK	20	320	Miller M=4	-79.6	-73.9	-65.8	>200
7	PR-ASK	20	250	Miller M=4	-79.9	-74.3	-67.2	>150
13	PR-ASK	20	160	Miller M=8	-85	-79.5	-73.3	>70

1. 测试仪器 CISC XPLORER 200, PER 10%, 输出功率 30dBm, 天线端口回波小于-20dB

2. 测试天线增益 12dBi, 4000 个标签

3. N/A 表示不支持此模式

从上表可以看出，SIMx200 提供了多达 8 种配置方式，列出了衡量读写器模块最重要的两项指标：灵敏度和读多标签速度。灵敏度与多标签速度之间需要作出权衡，因为灵敏度更好的模式下读标签速率低。在读得更好与读得更多之间，需要根据应用需求选择合适的模式。另一项需要注意的是当多阅读器同时工作时，会存在干扰。更小的 TARI 虽然加快了与标签的通信连接，但会增加发射信道的带宽，更容易干扰其他读写器。更高的标签的反向散射链路频率 (BLF) 提高了标签反向传输信号的速度，标签返回信号会落在相邻信道内，当有其他读写器正好工作在这个信道内时，读写器很可能无法解调出标签的返回信号。

盘存模式参数

针对不同的应用场景，SIMx200 提供了多种工作模式。优秀的处理算法也大大增强了产品

的应用适配性。

应用场景	工作模式	描述
少量标签 远距离盘存	普通模式	推荐 RF_MODE 13, session0, >50tag/s
	快速模式	推荐 RF_MODE 13, session0/1, 标志状态 A-B, >70tag/s
多标签盘存	EX10 快速模式	RF_MODE 自动调整, 推荐采用高波特率, 读全标签速度快, SIM7200: >700tag/s ; SIM5200: >500tag/s ; SIM3200: >300tag/s
高读速率 盘存	快速模式	推荐模式 RF_MODE 103(E710)、RF_MODE 120(E510)、 RF_MODE 12 (E310) , session0, 标志状态 A-B, 静态 Q 值, SIM7200: >700tag/s ; SIM5200: >500tag/s ; SIM3200: >300tag/s

引脚配置及功能



引脚编号	引脚名称	类型	描述
1	GND	电源	接地
2	GND	电源	接地
3	VCC	电源	供电电压, 4.75V-5.25V 输入
4	VCC	电源	供电电压, 4.75V-5.25V 输入
5	OUT1	数字 I/O	通用 I/O 口输出, 推挽输出
6	OUT2	数字 I/O	通用 I/O 口输出, 推挽输出
7	IN1	数字 I/O	通用 I/O 口输入
8	IN2	数字 I/O	通用 I/O 口输入
9	RXD	数字输入	模块 UART 输入, 3.3V 电平
10	TXD	数字输出	模块 UART 输出, 3.3V 电平
11	NC	空	请悬空, 不要接地
12	NC	空	请悬空, 不要接地
13	NC	空	请悬空, 不要接地
14	EN	数字输入	模块使能脚, 接低电平或悬空时模块使能, 接高电平时模块掉电
15	NRST	数字输入	模块复位脚, 接低电平时模块复位, 不使用时可悬空
	ANT1-ANT4	射频	射频天线端口 (50Ω)

*接口线束连接器: 间距 1.25mm P 数:15P 卧贴, 参考型号: 532611571 (MOLEX)

*射频天线端口连接器: SMA(外螺纹内孔)

应用说明

● 上电启动与 IO 接口

模块上电后，需要花费 100ms 进行初始化，在这段时间内不要拉低复位引脚，读写器模块也不会响应接收到的命令。

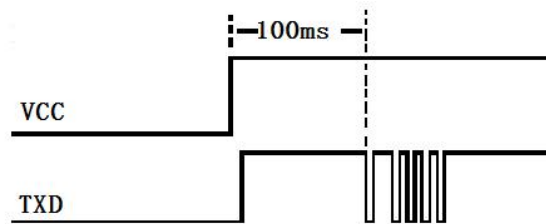

上电启动时间

NRST 上电复位解除时间小于 3ms，模块上电后，NRST 电平拉低会使内部模块的 MCU 重新启动。模块内 NRST 已接 100K 上拉电阻。如果模块已上电，触发复位的低电平保持时间需大于 2ms。当复位发生时，实际等待复位时间需大于 110ms。

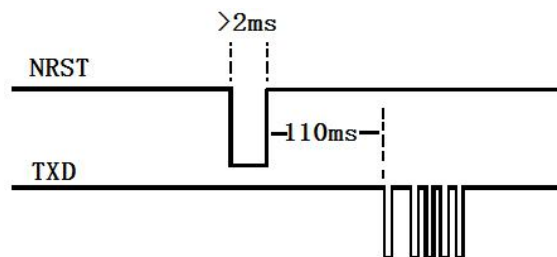

复位等待时间

通过发送获取 GPIO 命令与响应的的时间差测得响应时间。OUT1，OUT2 设置命令动作时间大于 78us（不含命令时间）。IN1，IN2 设置命令动作时间大于 88us（不含命令时间）。

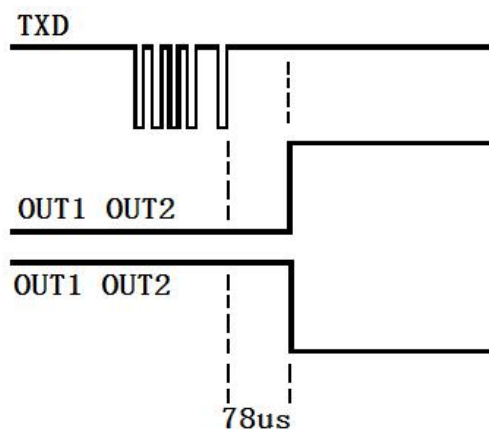

OUT1，OUT2 动作时间



IN1, IN2 动作时间

EN 脚内置 200K 下拉电阻，EN 脚接低电平或悬空时模块上电，EN 脚接高电平时模块掉电。

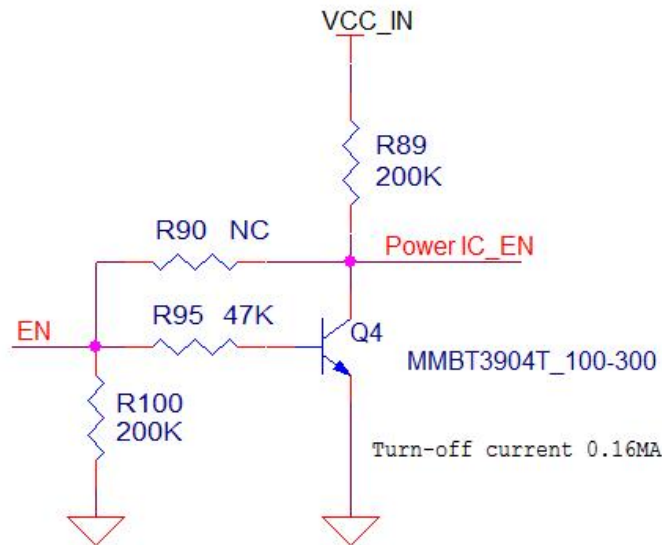

● 输入电源

VCC 电源输入建议使用一个 22~100uF 的钽电容, 如果尺寸限制, 也可以改为小尺寸的陶瓷电容, 并且至少并联一个 0.1uF 与一个 100pF 陶瓷电容。模块工作时的最大电流将近 1.6A (峰值电流), 盘存标签时, 模块内部功放会频繁开启和关闭, 这会导致模块输入端电源电压也随着产生波动。增加大容量电容可以减小这些电压的波动幅度, 滤除掉低频信号的干扰, 同时也会引起瞬间流过大, 根据模块供电电路的驱动能力, 选择合适的大容量退耦电容。而 0.1uF 和 100pF 电容用于滤除高频段的电源纹波, 因为高频段的干扰信号, 特别是工作频段的干扰信号进入到模块, 将会使模块的读标签性能下降, 此外陶瓷电容的加入也能防止模块工作时产生的高频信号通过电源通路, 干扰到其他电路系统。

由于模块工作电流较大, 连接模块的排线要足够粗, 否则连接线两端会产生过大的压差,

将使模块无法正常工作；过细的连接线也更容易产生辐射的干扰信号。

如果电源输入是 DC-DC 转换电路，最好选择开关频率超过 1.5MHz 的电源转换芯片，避免对标签返回的微弱信号产生干扰。

● 通讯串口

读写器模块采用 3.3V UART 串口进行数据通信，数据格式配置为 1 位起始位，8 位数据，1 位停止位，无校验位（8N1）。

串口的波特率需要满足模块上传标签数据的传输速率要求，盘存较多标签时，推荐波特率如下表所示：

RF_MODE ID	Forward Link Modulation	BLF (KHz)	Reverse Link Modulation	Baud Rate Select
103	DSB-ASK	640	FMO	921600
11	PR-ASK	640	FMO	921600
120	DSB-ASK	640	Miller M=2	>460800
1	PR-ASK	640	Miller M=2	>460800
345	PR-ASK	640	Miller M=4	>230400
15	PR-ASK	640	Miller M=4	>230400
12	PR-ASK	320	Miller M=2	>230400
3	PR-ASK	320	Miller M=2	>230400
5	PR-ASK	320	Miller M=4	>115200
7	PR-ASK	250	Miller M=4	>57600
13	PR-ASK	160	Miller M=8	>57600

● 天线端口

当模块与天线不匹配时，从天线反射回读写器模块信号过大，这会使接收灵敏度恶化，建议天线驻波比小于 1.5。当使用 E710 芯片的模块应用在需要快速读取大量标签的应用场合时，如果天线驻波较大导致接收灵敏度恶化后，会极大地增加读全标签的时间；对于距离近标签少的应用环境，选择使用 E510 或者 E310 的模块更加合适。

由于模块内的功放芯片与天线之间并未使用 RF 隔离器或者 RF 环形器进行隔离，当功放芯片与天线不匹配时，功放芯片输出的线性度与转换效率会发生变化。前者会使发射性能发生变化，比如功率输出减小，辐射杂散与频谱模板不符合当地无线电法规要求；后者则会使模块的功耗增加，工作温度更高，使用寿命减小，最差的情况下，功放芯片工作在匹配的不稳定区域产生自激，这种情况下，功放芯片很容易损坏。为保证模块工作的性能与稳定，建议将天线安装在应用环境中后，使用测试软件检测一下连接天线后的驻波比，天线驻波比要尽量小于 1.5。

● 散热说明

SIMx200 模块最大功率快速模式工作时发热量大，自带铝合金外壳满足不了散热要求，需要将模块固定在更大的金属散热片上。为保证导热效果需要在模块与散热片接触位置使用导热硅胶或硅脂。为了保护模块，当模块的检测温度达到 90℃时，会自动停止读写器模块盘存标签，需要再次盘存标签时，要重新发送盘存命令。

● 参考电路

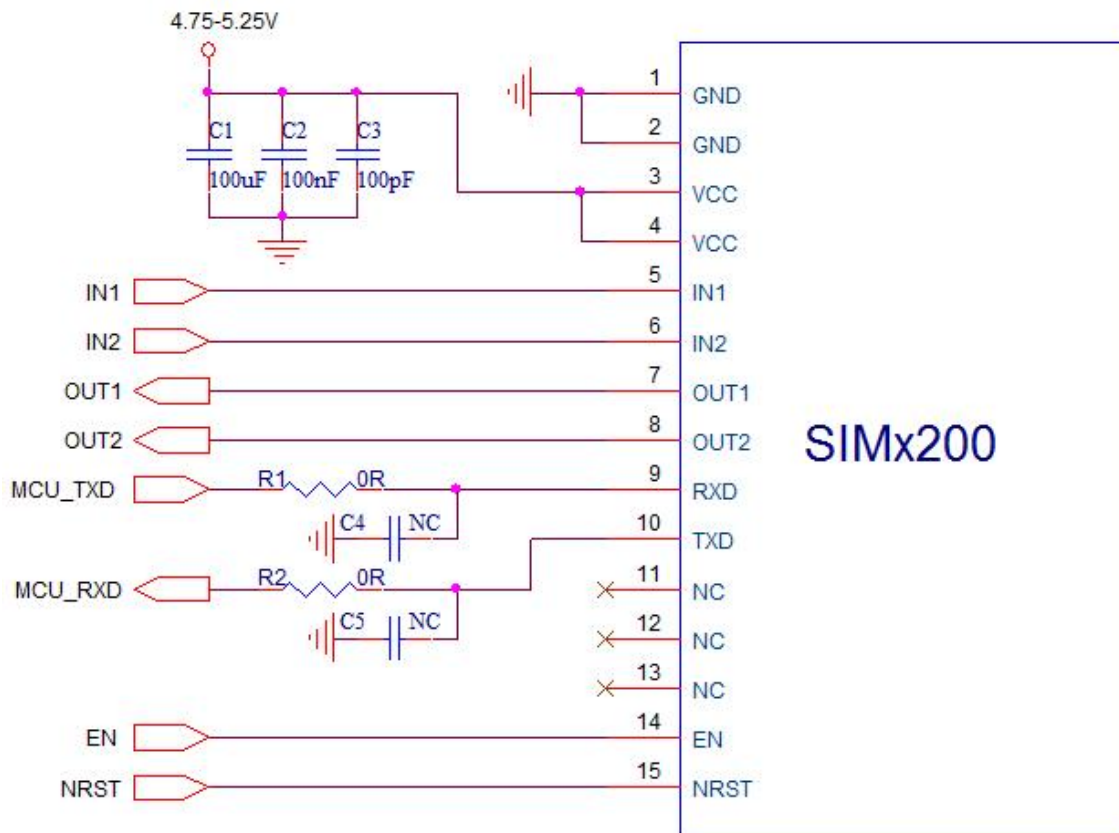

简化版参考电路

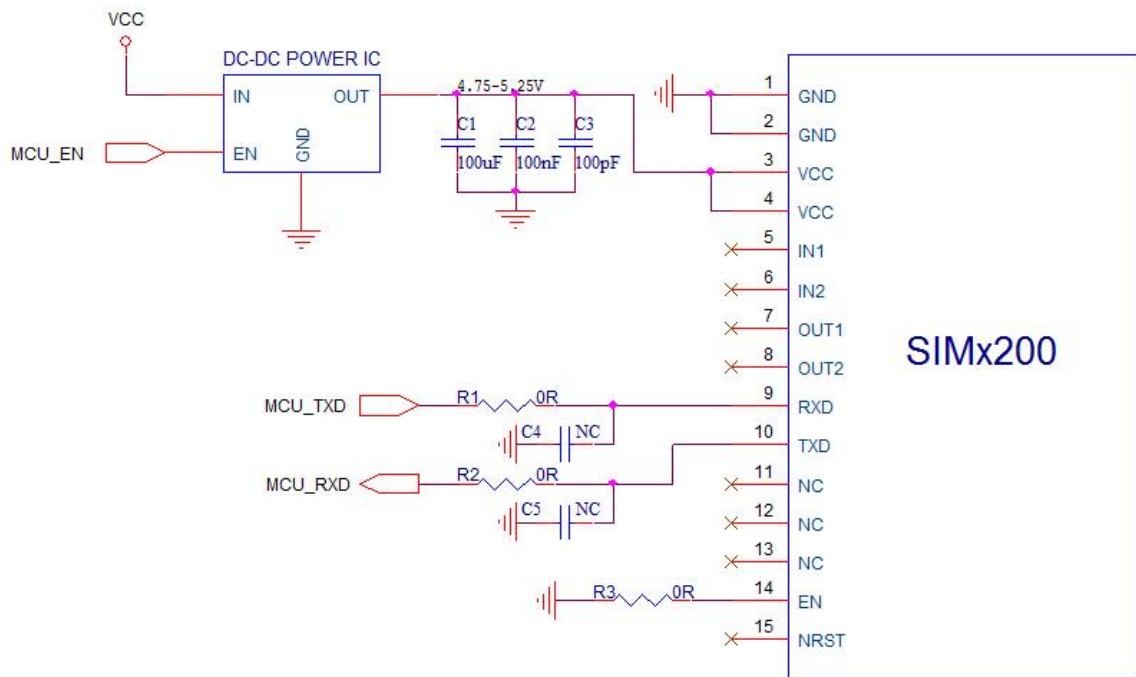

● 标记说明



SN 二维码

读写器芯片型号: RFIC: EX10
E710, E510, E310

SN: YYMMDDXXXX

SN 码:

YYMMDD: 年 月 日

XXXX: 模块生产编号

模块型号: MODEL: SIMX200

SIM7200

SIM5200

SIM3200

● 整体尺寸

74.8mm x 48.5mm x 8.0mm (长 x 宽 x 高), 重量 56g

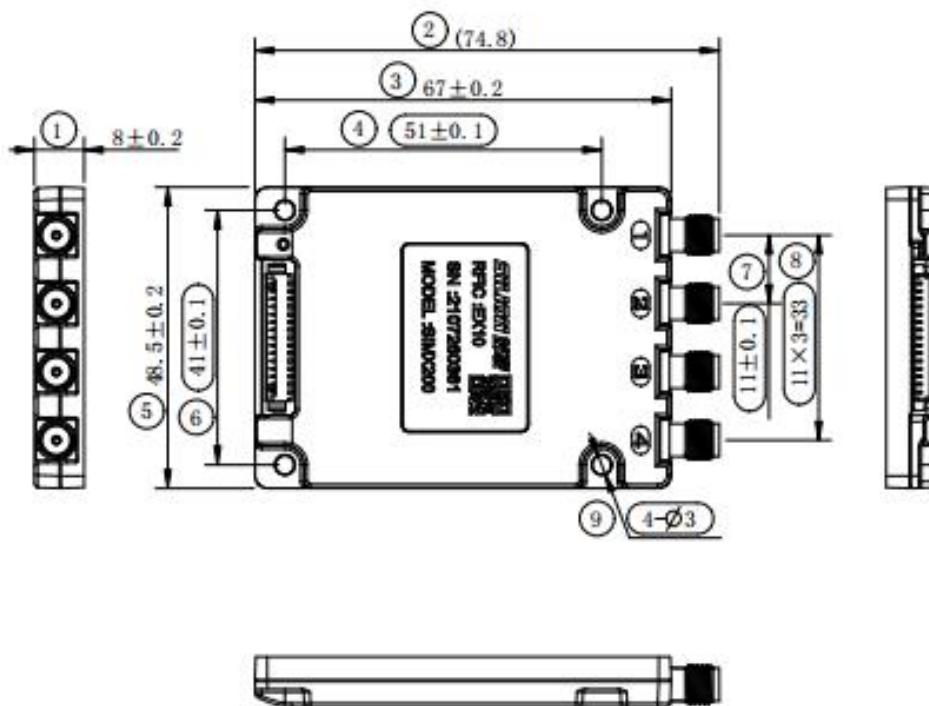

● 外观示意图



订购信息

产品型号	发射功率 (dBm)	支持频段	描述
SIM7200-0000	33	920MHz~925 MHz	SRRC
SIM7200-0100	30	902MHz~928 MHz	FCC
SIM7200-0300	30	865MHz~868 MHz	ETSI
SIM5200-0000	33	920MHz~925 MHz	SRRC
SIM5200-0100	30	902MHz~928 MHz	FCC
SIM5200-0300	30	865MHz~868 MHz	ETSI
SIM3200-0000	33	920MHz~925 MHz	SRRC
SIM3200-0100	30	902MHz~928 MHz	FCC
SIM3200-0300	30	865MHz~868 MHz	ETSI

订购前请与销售联系确认产品参数，可支持其他区域频段。

版本信息

版本	日期	修订内容
V1.0	2023/7/6	首版编辑
.....		

联系方式

如果您有产品需求或者在产品使用中有任何疑问，请随时与我们联系，我们将竭诚为您服务。

北京公司总部

地 址：北京市昌平区龙域北街3号金域国际中心A座5层

电 话：010-62153840，62153842，62153540

传 真：010-62153540 转 8008

网 址：www.silion.com.cn

电子邮件：sales@silion.com.cn

芯联创展华南区分公司

地址：深圳市南山区珠光路 52 号珠光创新科技园 1 栋 3 层

电 话：0755-26611567

传 真：0755-26617878

芯联创展华东区办事处

地 址：上海市嘉定区云谷路 599 弄 6 号楼 TEEC 上海中心大厦 311 室

电 话：18916488006

联 系 人：周经理

Overview

SIMx200 series four-channel modules are high-performance ultra-high-frequency RFID reader modules developed based on the latest generation of IMPINJ RF chips E710/E510/310.

The output power is 5dBm to 33dBm(adjustable), max reading range more than 12 meters (depend on the gain of antenna and the size of tags) , and possesses outstanding multi-tag inventory performance

SIMx200 has high power output, low power consumption, high stability, It employs advanced multi-tag recognition algorithms, enabling rapid tag identification whether the tags are in motion or stationary.

With superior anti-interference design and carrier offset capabilities, it can operate reliably in various environments.

It offers multiple configuration modes, making it suitable for a wide range of applications, including warehouses, logistics, production lines, and inspections, among others.



Applications

Model.	Sensitivity @PER 10%	Read rate @96 bit EPC
SIM7200	-85dbm	>1000
SIM5200	-78dbm	>600
SIM3200	-72dbm	>350

- Fixed device
- Desktop reader
- Printers
- Integrated reader

Characteristics

- ARMv7-M structure 32bit Cortex-M4 CPU, integrated FPU、MPU, DSP, highest operating frequency is 200MHz, with 512KBytes of flash memory.
- Support UHF EPC Class1 Gen2/ISO 18000-6C
- Windows, Linux, Android SDK and API based on C,C#/.NET, JAVA are provided.
- Supports temperature tag inventory, and the output parameters can include the RSSI
- Max 33dBm output power
- Features an excellent anti-collision algorithm, high sensitivity, and a tag inventory speed exceeding 1000 tags per second.
- Multiple inventory modes are available to suit most applications.
- The UART serial communication baud rate can be configured from 9600 bps and above.
- 2 inputs and 2 outputs of GPIO
- North American and European frequency bands: Full power at 30dBm with a power consumption of 5.75W.
Chinese frequency band: Full power at 33dBm with a power consumption of 7.5W.
- Aluminum alloy matte finish casing, weighing 56g
Dimension 74.8mm x 48.5mm x 8.0mm
- SRRC,CE,FCC certificated
- Meet ROHS requirement

The absolute maximum rating value.

Parameter	Symbol	MIN	Typical	MAX	Unit
Input voltage	VCC	-0.3		6	V
Enable voltage	VEN	-0.3		6	V
Reset (NRST) GPI(IN1 IN2) input low voltage	VIL			0.6	V
Reset (NRST) GPI(IN1 IN2) input high voltage	VIH	2.7			V
GPO(OUT1 OUT2) output current	IOH			15	mA
Module output current.	AVCC			20	mA
ESD protection voltage ¹	VESD	-2		2	kV
Antenna port (ANT) SWR ²	VSWR			8	/
Operating temperature	TC	-30		75	°C
Storage temperature	TS	-55		100	°C



ESD note:

。 When handling, packaging, and testing equipment, it is essential to observe appropriate precautions.

1. The antenna port testing conditions follow IEC61000-4-2 level 1, using contact discharge, while other interfaces are tested using the HBM model with contact discharge.
2. To prevent damage to the power amplifier chip, it is important to consider the maximum allowable standing wave ratio (SWR). To ensure optimal performance, it is recommended to maintain an SWR of less than 1.5 for the antenna.
3. Environmental temperature is related to the module's heat dissipation conditions, and the maximum temperature limit depends on these factors.

General working conditions.

Parameter	Symbol	MIN	Typical	Max	Unit
Input voltage	VCC	4.5	5	5.5	V
					V
Dropout voltage	VEN			0.4	V
Enable voltage		1.5			V
Reset (NRST) GPI(IN1 IN2) input low voltage	VIL			0.3	V
Reset (NRST) GPI(IN1 IN2) input high voltage	VIH	3			V
GPO(OUT1 OUT2) input voltage	IOH		10		mA
Module output current	AVCC		10		mA
Antenna port (ANT) SWR	VSWR			2.5	/
Operating humidity (non-condensing).	RH	5		95	%
Operating temperature	TC	-25		65	°C
Storage temperature	TS	-40		85	°C

General electrical parameters.

Parameter		Condition	MIN	Typical	MAX	Unit	
Frequency	Frequency range		860		960	MHz	
	Frequency step size ²			250/500		KHz	
	Frequency error	@25°C	-10		10	ppm	
Output	Output power		5		33	dBm	
	Power step size			1		dB	
	Output power accuracy	5dBm~33dBm	-1		1	dB	
	Output power flatness	5dBm~33dBm	-1		1	dB	
	Adjacent channel leakage ratio (ACLR)*	First adjacent channel			-45		dB
		Second adjacent channel			-65		dB
	20 dB occupied bandwidth*	RF_MODE 7			110		KHz
		RF_MODE 11			215		KHz
	Transmit spectrum template* ³	Margin	2				dB
	Spurious emissions (conducted) ⁴	Second harmonic			-55		dBm
Third harmonic				-40		dBm	
Measurement	Module temperature accuracy	-25°C~115°C ⁵	-4		4	°C	
	Tag RSSI measurement accuracy	@-60dBm	-3		3	dB	
	Tag phase measurement accuracy	@-60dBm	-5		5	degrees	
	Load return loss measurement accuracy	RL>18dB Attenuator connection.	-4		4	dB	
UART	Default baud rate	Data format:		115200		bps	
	Selectable baud rates	8N1	9600		921600	bps	
Power consumption	Power-down mode			0.00025		W	
	Low power consumption standby mode			0.1		W	
	Normal standby mode			0.8		W	

	Operating mode ⁶	NA、EU @30dBm		5.75		W
		China@33dBm		7.5		W

1. Frequency region selection is limited to a single frequency band and cannot support multiple frequency regions simultaneously.
2. Frequency step can be configured based on the selected frequency region.
3. Reference "ETSI EN 302 208" 4.3.5 Transmitter spectrum masks.
4. Testing conducted under full frequency conditions.
5. When the temperature exceeds 90°C, the module will forcibly stop inventory operations, and manual command input is required to restart inventory.
6. The module's operating power consumption may vary based on antenna matching conditions.

Note: * indicates testing conducted in inventory mode with RF_MODE 7, and the spectrum analyzer set to MAXHOLD.

Air interface mode parameters and performance.

RF_MO DE ID	Forward Link Modulation	Tari (us)	BLF (KHz)	Reverse Link Modulation	Receive Sensitivity Minimum ¹ (dBm)			Read Rate ² (tag s/s)
					E710	E510	E310	
11	PR-ASK	7.5	640	FM0	-63	N/A	N/A	>900
1	PR-ASK	7.5	640	Miller M=2	-69.3	-63.6	N/A	>650
15	PR-ASK	7.5	640	Miller M=4	-76	-70	N/A	>450
12	PR-ASK	15	320	Miller M=2	-75.1	-70.1	-62.1	>350
3	PR-ASK	20	320	Miller M=2	-75	-69.7	-62.2	>300
5	PR-ASK	20	320	Miller M=4	-79.6	-73.9	-65.8	>200
7	PR-ASK	20	250	Miller M=4	-79.9	-74.3	-67.2	>150
13	PR-ASK	20	160	Miller M=8	-85	-79.5	-73.3	>70

1. Testing equipment: CISC XPLORER 200, PER (Packet Error Rate) 10%, output power 30dBm, antenna port return loss less than -20dB.
2. Testing with a 12dBi antenna gain and 4000 tags.
3. "N/A" indicates that this mode is not supported.

From the table, it's evident that the SIMx200 offers up to 8 different configuration modes, highlighting the two most critical metrics for the reader module: sensitivity and multi-tag read speed. There's a trade-off between sensitivity and multi-tag read speed because modes with better sensitivity tend to have lower tag read rates. Choosing between reading better or reading more tags should be

based on the specific requirements of the application. Another important consideration is the interference that can occur when multiple readers are operating simultaneously. Smaller TARI values, while accelerating the communication connection to the tag, can increase the bandwidth of the transmission channel, making them more likely to interfere with other readers. Additionally, a higher tag backscatter link frequency (BLF) to improve the speed of the tag's reverse transmission signal may cause the tag's return signal to fall within adjacent channels. When other readers are operating in these adjacent channels, there is a higher likelihood that the reader may not be able to effectively demodulate the tag's return signal.

Inventory mode parameter

For different application scenarios, SIMx100 offers a variety of operating modes. Except for the temperature-controlled multi-tag inventory mode, all other modes are automatically handled by the reader module. This not only saves time on command interaction between the host and the reader module but also greatly enhances the product's versatility through excellent processing algorithms.

Scenario	Working mode	Description
Few tags Distance inventory	Normal mode	Recommend RF_MODE 13, session0, >50tag/s
	Fast mode	Recommend RF_MODE 13, session0/1, Status indicator A-B, >70tag/s
Multi-tag inventory	EX10 fast mode	RF_MODE Automatic adjustment is recommended to achieve a faster reading speed by using higher baud rates. SIM7200: >700tag/s ; SIM5200: >500tag/s ; SIM3200: >300tag/s
High read rate Inventory	Fast mode	Recommended mode RF_MODE 103 (E710) 、RF_MODE 120 (E510) 、RF_MODE 12 (E310) , session0, Status indicator A-B, static Q value, SIM7200: >700tag/s ; SIM5200: >500tag/s ; SIM3200: >300tag/s

Pin configuration and functions.



Pin No.	Name	Type	Description
1	GND	Power	GND
2	GND	Power	GND
3	VCC	Power	Supply voltage: Input from 4.75V to5.25V
4	VCC	Power	Supply voltage: Input from 4.75V to5.25V
5	OUT1	Digital I/O	General I/O Port Output: Push-pull output.
6	OUT2	Digital I/O	General I/O Port Output: Push-pull output.
7	IN1	Digital I/O	General I/O Port Input.
8	IN2	Digital I/O	General I/O Port Input.
9	RXD	Digital input	Module UART Input, 3.3V logic level
10	TXD	Digital output	Module UART Input, 3.3V logic level
11	NC	Empty	Please leave it unconnected, do not ground it.
12	NC	Empty	Please leave it unconnected, do not ground it.
13	NC	Empty	Please leave it unconnected, do not ground it.
14	EN	Digital input	Module enable pin: The module is enabled when connected to a low logic level or left floating. It powers down when connected to a high logic level.
15	NRST	Digital input	Module reset pin: The module is reset when connected to a low logic level. It can be left floating when not in use.
	ANT1-ANT4	RF	RF Antenna Port (50Ω).

*Interface wire harness connector: Pitch 1.25mm, Number of Pins: 15P, SMT (Surface Mount Technology); Reference Model: 532611571 (MOLEX).

*RF antenna port connector: SMA (external thread, internal hole).

- **Application instruction**
- **Power-On Start and IO Interface**

- After powering on the module, it requires approximately 100ms for initialization. During this period, it's important not to pull the reset pin low, and the reader module will not respond to received commands.

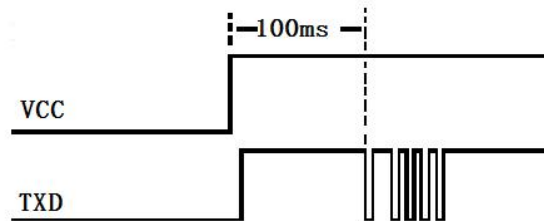

Power-on startup time

After powering up, NRST release time is less than 3ms. If NRST is pulled low after power-on, it will restart the internal MCU. A 100K pull-up resistor is already connected to NRST. If the module is already powered, the reset trigger should be held low for more than 2ms. The actual reset time should be greater than 110ms.

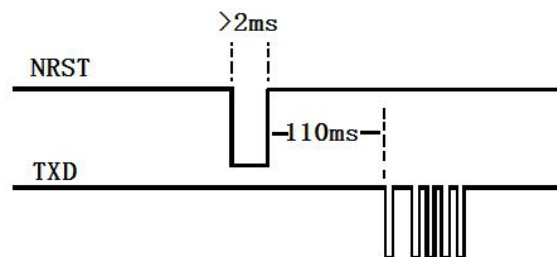

Reset waiting time

The response time is measured by sending a GPIO command and calculating the time difference between sending the command and receiving the response. The command action time for OUT1 and OUT2 should be greater than 78us (excluding the command time). For IN1 and IN2, the command action time should be greater than 88us (excluding the command

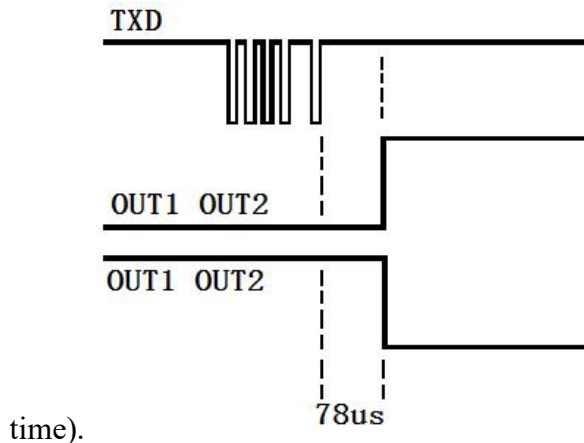

OUT1, OUT2 action time

IN1, IN2 action time

The EN pin has a built-in 200K pull-down resistor. When the EN pin is connected to low or left floating, the module powers on. When the EN pin is connected to high, the module powers

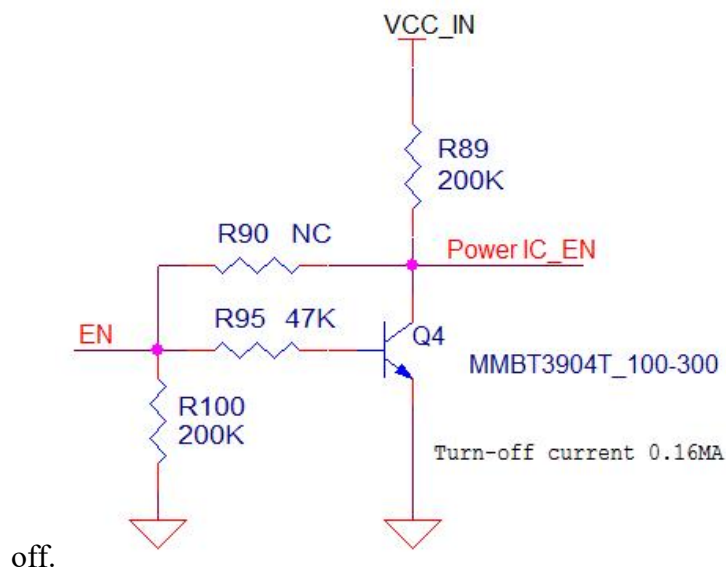

● Input power

VCC Power Supply Input:

Use a 22~100uF tantalum capacitor if possible. If space is limited, smaller ceramic capacitors can be used, along with at least one 0.1uF and one 100pF ceramic capacitor in parallel. The module can draw a peak current of nearly 1.6A during tag inventory, causing voltage fluctuations. Adding larger capacitors helps reduce these fluctuations, filter out low-frequency interference, and prevent high-frequency signals generated by the module from affecting other circuits. Thicker wires are recommended to connect the module due to its higher current. If using a DC-DC converter, choose a chip with a switching frequency above 1.5MHz to avoid interfering with tag signals.

● Communication Serial Port

The reader module uses a 3.3V UART serial port for data communication, configured with a data format of 1 start bit, 8 data bits, 1 stop bit, and no parity (8N1).

The serial port baud rate should meet the data transfer rate requirements for uploading tag data. When conducting inventory with a large number of tags, the recommended baud rates are as follows:

RF_MODE ID	Forward Link Modulation	BLF(KHz)	Reverse Link Modulation	Baud Rate Select
103	DSB-ASK	640	FM0	921600
11	PR-ASK	640	FM0	921600
120	DSB-ASK	640	Miller M=2	>460800
1	PR-ASK	640	Miller M=2	>460800
345	PR-ASK	640	Miller M=4	>230400
15	PR-ASK	640	Miller M=4	>230400
12	PR-ASK	320	Miller M=2	>230400
3	PR-ASK	320	Miller M=2	>230400
5	PR-ASK	320	Miller M=4	>115200
7	PR-ASK	250	Miller M=4	>57600
13	PR-ASK	160	Miller M=8	>57600

● Antenna Port:

Mismatch between the module and antenna can lead to excessive signal reflection from the antenna to the reader module, causing a degradation in receiver sensitivity. It is recommended to maintain an antenna VSWR (Voltage Standing Wave Ratio) below 1.5. In applications requiring rapid reading of a large number of tags, especially when using modules based on the E710 chip, a high antenna VSWR that degrades receiver sensitivity can significantly increase the time required for reading all tags. For applications with fewer tags at closer distances, choosing modules based on the E510 or E310 may be more suitable.

Since there is no RF isolator or RF circulator used between the power amplifier chip in the module and the antenna, mismatches between the power amplifier chip and the antenna can affect

linearity and conversion efficiency. The former can result in changes in transmission performance, such as reduced power output, radiation of spurious signals, and non-compliance with local radio regulations regarding spectrum masks. The latter can increase the module's power consumption, operating temperature, and reduce its lifespan. In the worst-case scenario, the power amplifier chip may operate in an unstable region due to mismatches, leading to self-excitation, which can easily damage the power amplifier chip. To ensure optimal module performance and stability, it is recommended to install the antenna in the application environment and use testing software to measure the VSWR after connecting the antenna. The VSWR should ideally be below 1.5.

● Heat Dissipation

The SIMx200 module generates significant heat during fast mode operation, and its built-in aluminum alloy casing may not provide adequate heat dissipation. To ensure effective heat conduction, it is necessary to mount the module on a larger metal heat sink. Additionally, thermal conductive silicone grease or compound should be applied at the contact points between the module and the heat sink. To protect the module from overheating, it will automatically cease tag inventory when the detected temperature reaches 90°C. In such cases, you will need to resend the inventory command to resume tag inventory.

● Reference

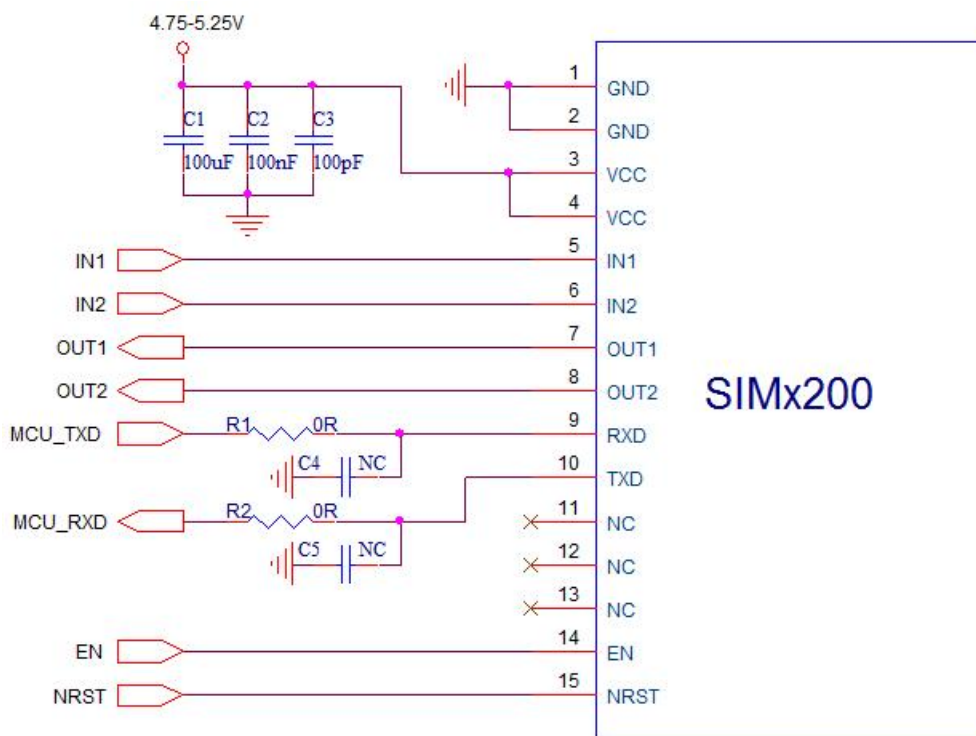

Simplified Reference Circuit

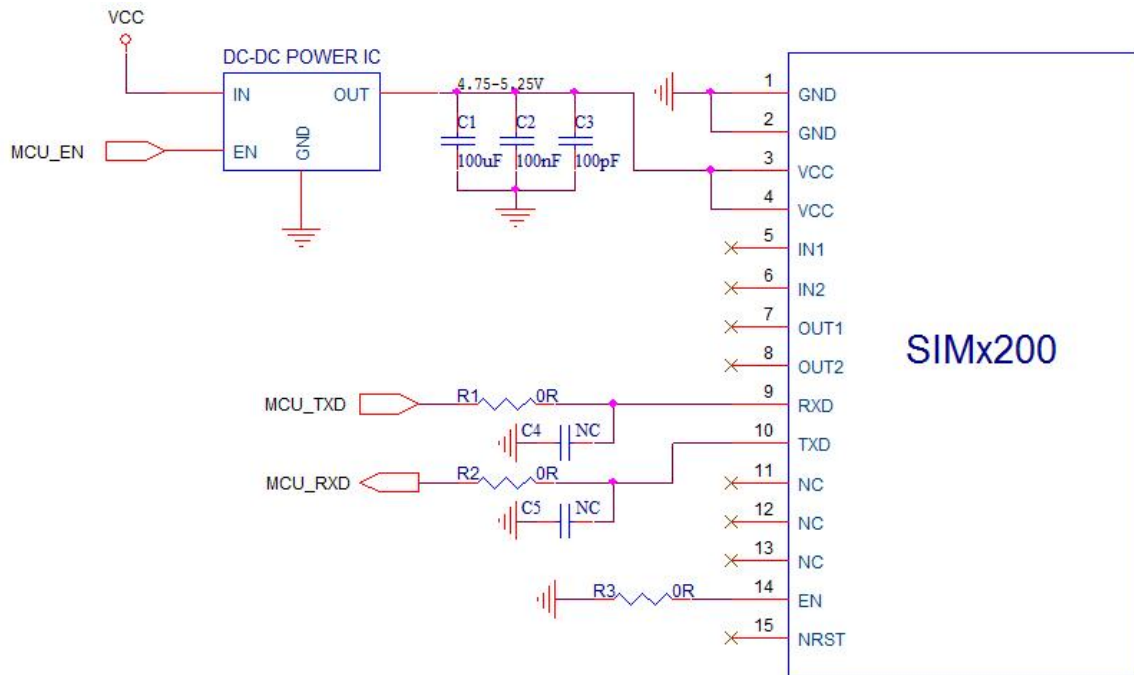

● Label Explanation

Chipset:
E710, E510, E310

Model no.
SIM7200
SIM5200
SIM3200



SN QR code

RFIC: EX10

SN: YYMMDDXXXX

MODEL: SIMX200

SN NO.:

YYMMDD: year/month/date

XXXX: Module

Production Serial

● **Dimension**

74.8mm x 48.5mm x 8.0mm, weight 56g

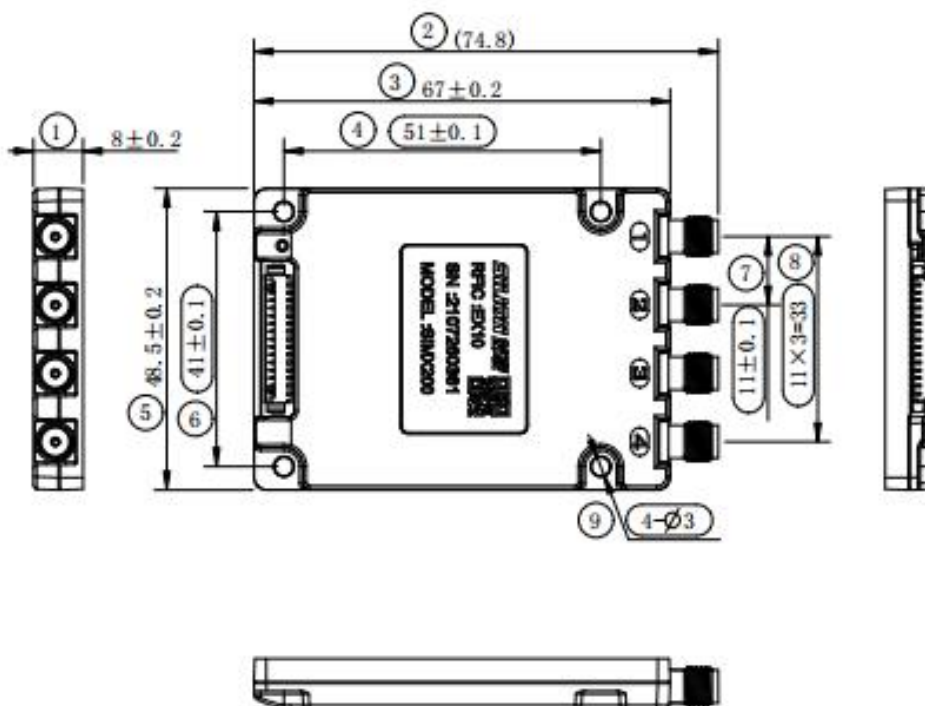

● **Appearance**



Order information

Model no.	Output (dBm)	Supported frequency	Description
SIM7200-0000	33	920MHz~925 MHz	SRRC
SIM7200-0100	30	902MHz~928 MHz	FCC
SIM7200-0300	30	865MHz~868 MHz	ETSI
SIM5200-0000	33	920MHz~925 MHz	SRRC
SIM5200-0100	30	902MHz~928 MHz	FCC
SIM5200-0300	30	865MHz~868 MHz	ETSI
SIM3200-0000	33	920MHz~925 MHz	SRRC
SIM3200-0100	30	902MHz~928 MHz	FCC
SIM3200-0300	30	865MHz~868 MHz	ETSI

Please contact our sales team to confirm product specifications before placing an order. We can support other regional frequency bands as well.

Version

Version	Date	Modify content
V1.0	2023/7/6	First edition
.....		

Contact

If you have any product requirements or any questions about using our products, please feel free to contact us at any time. We are here to serve you wholeheartedly.

Main Office in Beijing

Location: 5th Floor, Block A, Golden International Center, No. 3 Longyu North Street, Changping District, Beijing, China.

Mobile: 010-62153840, 62153842, 62153540

Fax: 010-62153540 转 8008

Website: www.silion.com.cn

Email: sales@silion.com.cn

SILION Shenzhen Branch Office

Location: 3rd Floor, Building 1, Zhuguang Innovation Technology Park, No.
52 Zhuguang Road, Nanshan District, Shenzhen, China.

Mobile: 0755-26611567

Fax: 0755-26617878

SILION Shanghai Branch Office

Location: Room 311, Building 6, TEEC Shanghai Center, 599 Lane, Yungu
Road, Jiading District, Shanghai, China.

Mobie: 18916488006

Contact: Mr. Zhou