

INSTALLATION GUIDE

I2R-T2DC Series Surge Protective Devices

The **L-COM I2R-T2DC Series SPDs** are designed to protect DC power systems, including the DC-side of Photovoltaic systems, against the risk of the harmful effects of transient surges. These surges are the result of:

- Direct and indirect lightning strikes
- Power company load switching
- Upstream load switching at other facilities

Models are available for single-pole ‘S’, two-pole ‘T’ and three-pole ‘Y’ protection configurations.

FEATURES

- UL recognized Type 2ca Surge Protective Devices (ANSI/UL 1449 4th, CSA-C22.2) for DC & PV/ Photovoltaic system.
- Max. permitted DC Voltage (Vpvd): 85V~1500Vdc
- Surge capacity 50kA 8/20μs per pole
- Short circuit current rating (SCCR) up to 100kA
- Pluggable design with window fault indication
- Remote alarm signal optional
- Comply with IEC 61643-11/ 61643-31 /EN50539-11



PRODUCT SPECIFICATIONS

Series	I2R-T2DC
SPD category	ANSI/UL1449 4th , CSA-C22.2, Type 2ca SPD
Connection Type	Parallel Connected
Ports	1
System voltage (Vdc) Un	48~1500 Vdc
Surge capacity	50 kA
Nominal discharge current (In)	20 kA
Protection mode	“+”/“-“ to Ground, or “+” to “-“
SCCR rating	30~100kA
Failure indicators	Flag indicator green -normal ; red - failure
Remote Alarms	Isolated Form C AC: 250V/0.5A DC: 250V/0.1A; 125V/0.2A; 75V/0.5A
Location	Indoor
Enclosure rating	IP20, UL94 V0
Power Connecting	Single-strand #2AWG or 35mm ² ; multi-strand #4AWG or 25mm ²
Signal cable(Remote alarm)	Max. # 16AWG or 1.5mm ²
Working environments	Temperature -40°C~+85°C, Humidity relative 5~95% (25°C) , Altitude≤2km
Storage	Temperature -10°C~+45°C, Humidity relative ≤75% (25°C)
Dimensions, W x D x H	100x18x66 mm (1 pole)
Applicable standards.	ANSI/UL1449 4th ,IEC61643-31, CSA C22.2,ANSI/IEEE C62.41 etc.
Approvals, Certifications	UL/CE

INSTALLATION

1. De-energize power when installing or replacing SPDs!
2. Install the DIN mounting rail (35mm, To EN 50022).
3. Snap lock the SPDs to the rail.
4. Connect wiring to the indicated terminals
5. Ensure compliance with supplied instruction.

INSTALLATION GUIDE

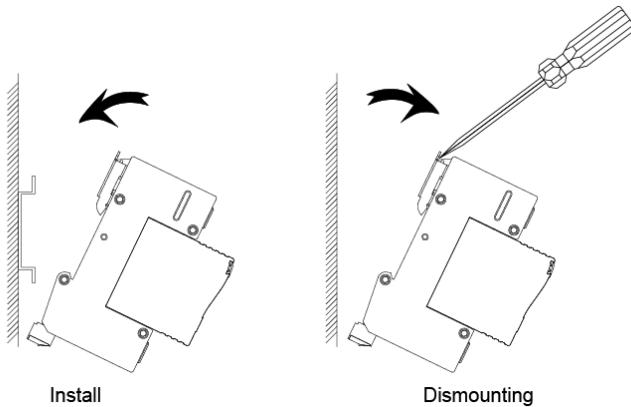
WARNING!



Only qualified personnel should install or service this system. Electrical safety precautions must be followed when installing or servicing this equipment. To prevent risk of electrical shock, turn off and lock out all power sources to the unit before making electrical connections or servicing.

For proper and safe operation, neutral and ground MUST be reliably connected. Failure to operate this unit from a solidly grounded power source of the proper configuration will reduce or impede operation, and may result in unit failure.

6. Apply power and observe correct operation of Status Indicators, and remote alarm facilities if utilized.
7. Never Hi-Pot test Any SPD. (Will prematurely fail or damage SPD).



WIRING CONNECTIONS

Before making connections to the unit, verify that the unit model number and nameplate voltage rating are appropriate for connection to the intended power source. For best performance, unit should be positioned so that the length of the wiring to the surge protective device (SPD) unit is minimized.

➤ Wiring SPDs in PV system

A PV SPD should be installed as close as possible to the inverter. If the length of the wiring between this SPD and the PV generator (distance L, see Figure 2, 3) is greater than 10 m, it is needed to protect the PV generator with a complementary SPD nearby (see Figure 2, 3).

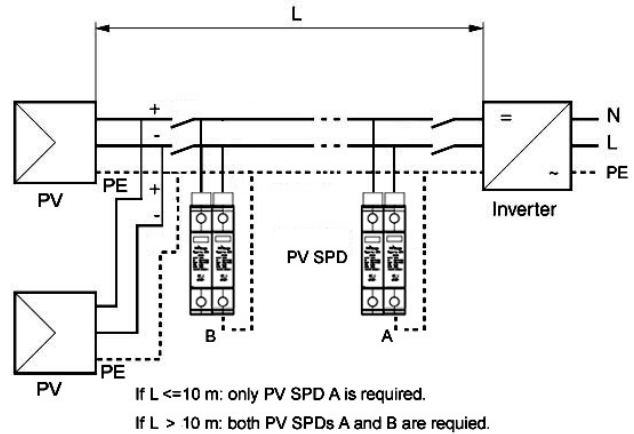


Fig 2: Positions of SPDs (T configuration) in the DC part stipulated in Guide IEC 61643-32

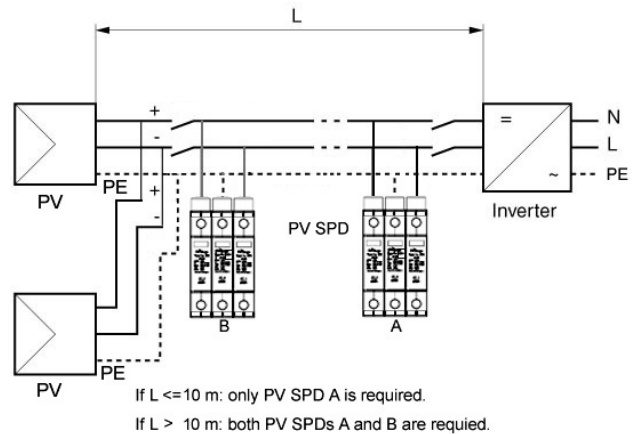


Fig 3: Positions of SPDs (Y configuration) in the DC part stipulated in Guide IEC 61643-32



WARNING !

Select the proper L-COM SPD unit according to your system voltage, configuration and the anticipated surge environment.

Prior to install the SPD, ensure that your facility electric supply system is properly installed and connected in according with all applicable national and local codes and safety procedure.

INSTALLATION GUIDE

Each SPD terminal is designed to accept wire sizes from #12AWG (4 mm²) to #2AWG (35 mm²)-solid conductor or #4AWG (25 mm²)-stranded conductor. Insulation should be stripped back 12 mm before terminating into tunnel terminal. Do not use excessive force when tightening the terminal. (2 Nm is recommended.)

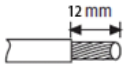
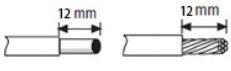
Conductor Type		
Min cross-section	+/- terminal: #12AWG (or 4 mm ²), PE terminal: #10AWG (or 6 mm ²)	
Max cross-section	#4AWG or 25 mm ² (stranded)	#2AWG or 35mm ² (solid)
Insulation stripped back	12 mm	

Table 1: Connection wire size

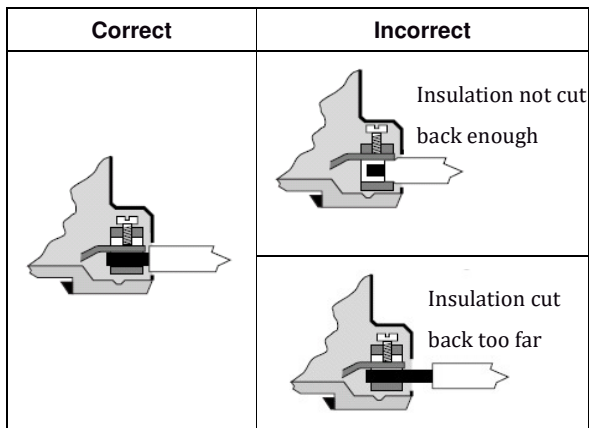
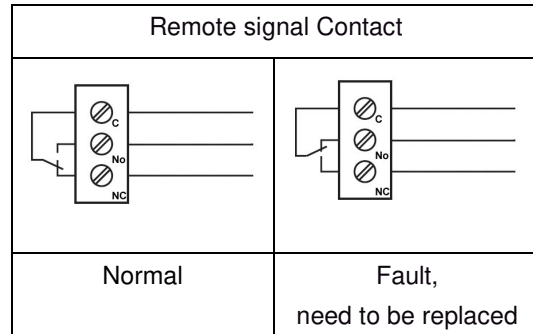


Fig 4: Tightening the terminal

STATUS INDICATOR& REMOTE SIGNAL

A characteristic of all transient and surge protection devices is that they degrade in proportion to the magnitude and number of incident surges to which they have been subjected. Status indication should be periodically monitored to determine if replacement is required.

While the indicator windows of SPDs turn to **RED** or C to No of remote signal contact to be electrical connection, the pluggable module should be replaced ASAP.



Tab2: Remote signal contact indication

PRODUCT RATINGS AND LIMITATIONS

Vp_{dc} – The maximum permitted DC voltage, as specified by the manufacturer, which can be applied across the DC SPD.

Voltage Protection Rating – To obtain the voltage protection rating (VPR), in accordance with the Standard for Safety, Surge Protective Devices (SPDs), Standard 1449 Fourth Edition, released 2014, indicated on this product, the wire specified must be utilized to connect the SPD to your facilities power grid. Connections made with unapproved conductors may result in different VPR.

Circuit Ampacity Limitations – This product has been tested to withstand, without exposing live circuits or components on power sources, a voltage of or above U_{p_{dc}} rating, and fault currents of up to 50,000~100,000 A, as described in the Standard for Safety, Surge Protective Devices (SPDs), Standard 1449, Fourth Edition, released 2014.

TROUBLESHOOTING

If any of the diagnostic indicators indicates a problem, check all connections and voltages to the unit. If all connections are made and reliable, and proper voltages are supplied to the unit, please contact L-com.

Tel: 866.411.2925

Web site: www.l-com.com

INSTALLATION GUIDE

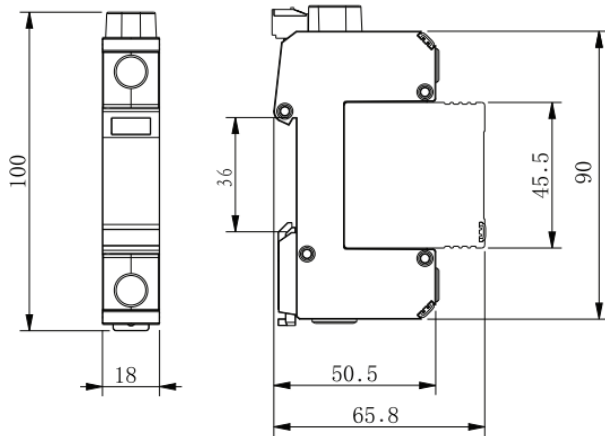
NOTE

This installation guide is not comprehensive. It's assumed the user will follow established safety precautions for working in an electrical environment. For more information on safety precautions and procedures, please find from related organizations as below.

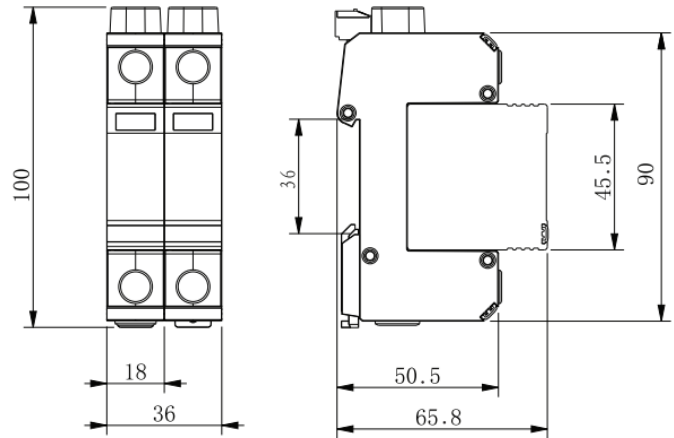
- Underwriters Laboratories(UL)
- American National Standards Association(ANSI)
- Institute of Electrical and Electronics Engineers (IEEE).
- National Fire Protection Association (NFPA)
- National Electrical Mfgs. Association(NEMA)
- International Electrotechnical Commission(IEC)

Installation Dimensions

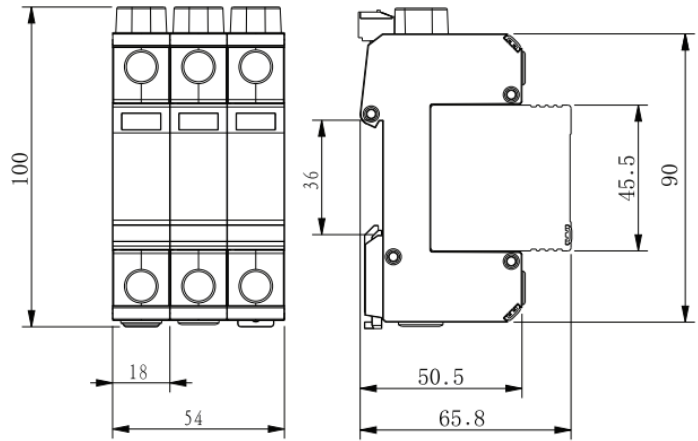
Note: units are in mm



1) Single pole, "S" configuration



2) Two poles, "T" configuration



3) Three poles, "Y" configuration

