

NO:TH-23882

承认申请书

APPLICATION FOR APPROVAL

产品符合欧盟 RoHS 环保要求

CUSTOMER: 深圳市立创电子商务有限公司
PART NAME: 瓷介电容器
DRAUGHT BY: 宋桂涛
CHECKED BY: 秦建国
APPROVERED BY: 刘祥峰
DATE: Oct. 13, 2023

APPROVAL	FIELD

厂商
沂南同皓电子元件有限公司
中国·山东沂南县城花山路
电话 (TEL):
传真: (FAX):
邮编: (P. C.):
网址: (WEB SITE)
电邮 (E-Mail):

Mfr.
YINAN DON'S ELECTRONIC COMPONENT CO., LTD
HUASHAN ROAD, YINAN COUNTY, SHANDONG, CHINA
0086-539-3255539
0086-539-3221669
276300
<http://www.sdtfly.com>
ynthjsb@126.com

沂南同皓电子元件有限公司

YINAN DON'S ELECTRONIC COMPONENT CO., LTD.



变 更 清 单
REVISION LIST

序号 NO.	日 期 DATE	变更内容 CHANGE CONTENT	变更标记 REMARK
1	2023-10-13	首次提供 First provides	-----
2			
3			
4			
5			
6			
7			
8			
9			
10			
11			
12			
13			
14			
15			
16			
17			
18			
19			
20			

瓷介电容器

Ceramic Capacitors

□用途 (Application)

该产品主要用于彩电、计算机显示器、复印机、医疗设备、安检设备、照明等的电源电路、输出电路等部分。
 Using for H-out and supply circuits of color TV and monitor, copy machine, Medical equipment, Security inspection equipment, lighting.

□外观及结构 (Appearance and Structure)

编 码 CODE	品 名 CODE NO.	Dmax (mm)	Tmax (mm)	F (mm)	d (mm)
	CC81-10KV-ZM-101K	8.0	8.0	7.0	0.55
	CC81-10KV-ZM-251K	12.0	9.0	10.0	0.80

外观结构
STYLE

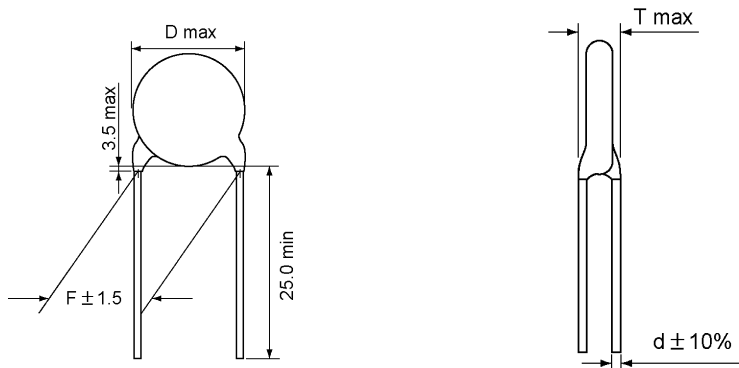

□标识方法 (Marking)

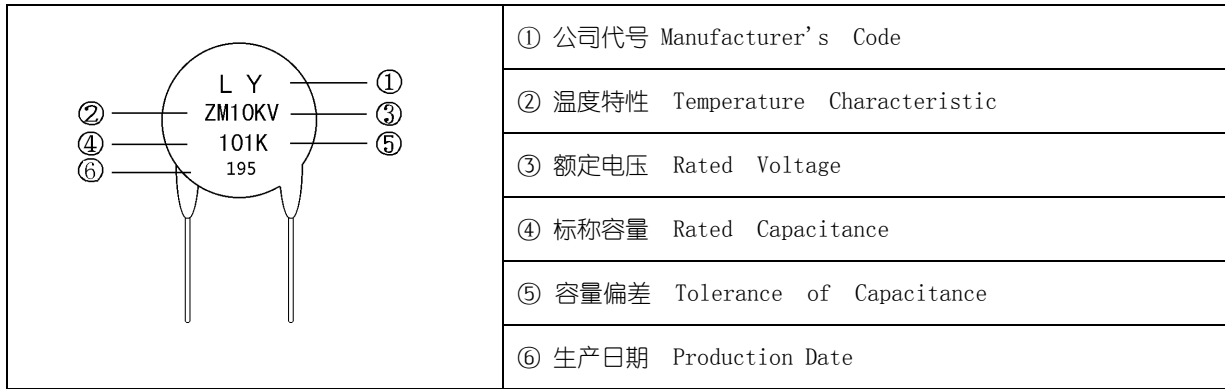

说明：生产日期第一位表示制作年度，标示方法参照年度对照表；第二位表示制作月份，第三位表示具体制作日期，标示方法参照 34 进制对比表；例如：生产日期 195 表示：1:2021 年 9:9 月，5:5 日

(Production date first said the annual, marking methods according to annual comparison table; second said production month, third said the specific production date marking method of comparison, table 34 hexadecimal; Example: Production date 195 show: 1:2021year 9: september 5: the 5 day):

年度对比表：

年 度	2021	2022	2023	2024	2025	2026	2027
年代码	1	2	3	4	5	6	7
年 度	2028	2029	2030	2031	2032	以此类推	
年代码	8	9	0	1	2		

34 进制对比表：

34 进制	0	1	2	3	4	5	6	7	8	9	A	B	C	D	E	F	H
10 进制	0	1	2	3	4	5	6	7	8	9	10	11	12	13	14	15	16
34 进制	J	K	L	M	N	P	Q	R	S	T	V	W	X	Y	Z		
10 进制	17	18	19	20	21	22	23	24	25	26	27	28	29	30	31		

□结构(Structure)

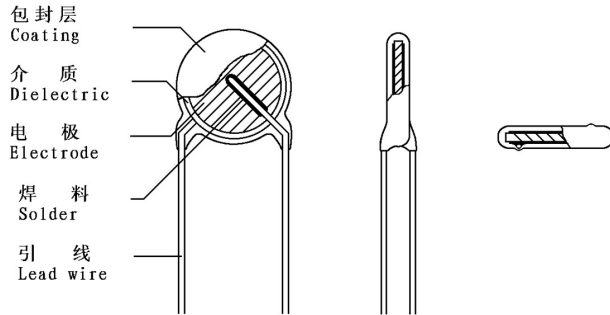

包封层(Coating) : 环氧树脂(Epoxy Resin)

介质(Dielectric): 陶瓷 (Ceramic)

电极(Electrode) : 银 (Silver)

焊料(Solder) : 锡(Alloy Tin)

引线(Lead Wire) : 镀锡引出线(Lead)

□主要材料(Main Material)

$SrCO_3$ $BaCO_3$ TiO_2 Bi_2O_3 $CaCO_3$ Nb_2O_5 MgO

银膏(Silver paste) 环氧树脂(Epoxy Resin)

□室内条件(Room Condition)

温度(Temp.): 15~35℃ 湿度(R.H.): 45~75%

气压(Atm pressure): 86~106kPa (860~1060mbar)

□测试条件(Test Condition)

温度(Temp.): 常规测试 (Routine test): 15~35℃,

有疑义时测试 (Test in case of disagreement): 20±2℃

相对湿度(R.H.): 45~75%

电压(Vol.): 1.0±0.2Vrms 频率(Freq.): 1±0.2KHz

□容量—温度变化曲线 Cap.—Temp. Curve

ZM

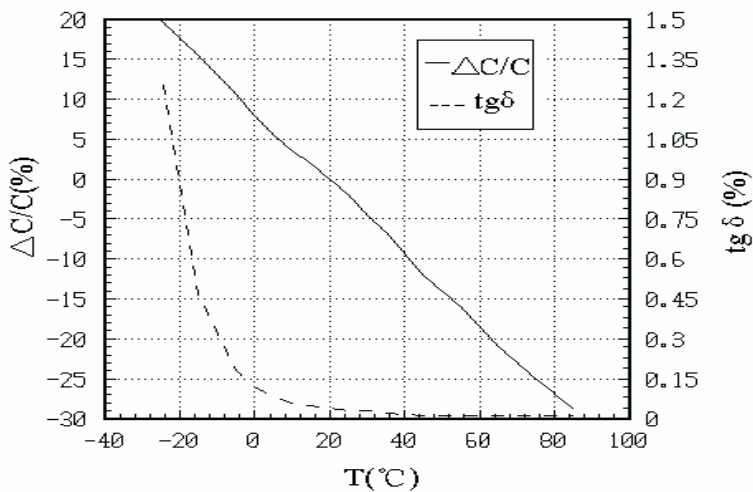

□型号命名方法 Part Code Designation

CC81—10KV—ZM—101 K
 ① ② ③ ④ ⑤

①种类 Class

代码 Code	种类 Class
CC81	I类高压 Class I High-Voltage

④标称容量 Rated Capacitance

代码 Code	静电容量 Capacitance
101	100pF
251	250pF

②额定电压 Rated Voltage

代码 Code	额定电压 Rated Vol.	代码 Code	额定电压 Rated Vol.
10KV	10000V. DC		

⑤容量允差 Tolerance

代码 Code	容量允差 Tolerance
K	± 10%

③温度特性 Temperature Characteristic



代码 Code	容量变化 Cap. Change
ZM	N4700 (-4700±1000ppm/°C)

□包装 (packing)

1、包装数量 (packing quantity):

成型方式 Molding mode	包装数量(只) Quantity per bag (pcs)
b	50 ~ 200

2、包装标识 (packing marking):

示例(Example)	项 目 (Item)	
		公司商标 (Manufacturer's Marking)
		环保标识 RoHS Designation
	物料编码 Code	用户要求时 When the customer require
	规格型号 Model	详见如上表格, (Please see the detail in the upper sheet)
	生产批号 Product lots	生产批号 Product lots
	成型代号 lead shape	用户要求时 When the customer require
	生产日期 Productive date	产品生产时间 the produce time of the product
	数 量 Quantity	每盒的包装数量 the packing quantity per plastic bag

3、外包装 (over-wrap packing):

内包装箱 (internal packing boxes) (A1:360×200×140mm、A2:198×177×138mm)

外包装箱 (over-wrap boxes) (B1:460×380×220mm、B2:425×380×170mm)

装箱数量应为最小包装的整数倍。(The packing quantity should be integral multiple of minimal packaging.)

□规格及试验方法 Specification and Test Method

项 目 ITEM		规 格 SPECIFICATION	试 验 方 法 及 条 件 TEST METHOD AND CONDITION									
1. 使用温度范围 Operating Temp. Range		-25℃~+ 85℃										
2. 外观尺寸 Appearance and Dimension		外观无可见损伤 尺寸在规格内 Appearance has no marked defect. Dimensions shall be within specified tolerance.	外观用目视法观测 尺寸用游标卡尺测量 Appearance be watched on sight Dimension be measured by caliper									
3. 标识 Mark		应清晰可见 Should be discerned easily.	用目视法观测 Be watched on sight									
4. 静电容量 Capacitance		在规格范围内 Within specified tolerance	温度 Temp. 20±2℃ 电压 Vol. 1.0±0.2Vrms 频率 Freq. 1±0.1KHz									
5. 损耗因数 Dissipation Factor		0.3%max	同上 Same condition as capacitance									
6. 绝缘电阻 Insulation Resistance		大于 10,000MΩ 10,000MΩmin	500±50V. DC 的电压充电一分钟。 The insulation Resistance shall be measured with 500±50V. DC within 60±5 sec of charging.									
7. 耐电压 Dielectric Strength	端子间 Between Lead Wires	无不良 No failure.	端子间施加 150%的额定电压一分钟。 (充放电电流<50mA) Apply a DC voltage of 150% of the rated voltage for 1 min. (Charge/discharge current<50mA)									
	端子与外壳间 Body Insulation	无不良 No failure.	如图, 将电容器的引线连在一起, 主体外紧包一层金属箔, 边沿距引线 3-4mm, 在电容器引线和金属箔间施加额定电压一分钟。 (充放电电流<50mA) The terminals of the capacitor shall be connected together, A metal foil shall be closely wrapped around the body of the capacitor to the distance of about 3-4 mm from each terminal, A voltage of the rated is applied between the capacitor lead wires and the metal balls for 1 min. (Charge/discharge current<50mA)									
8. 温度特性 Temp. Char.	Ct - C3 C3	-4700±1000ppm/℃	静电容量测试须依下列顺序测试。 试验前: 电容器应放置在 85±2℃ 的温度下 1 小时, 然后在常温下恢复 24±2 小时后测试。 The capacitance measurement shall be made at each step specified as following. Capacitance change from the volume of step 1 shall not exceed the limit specified. pre-treatment: The capacitor shall be placed at 85±2℃ for 1 hour, then placed at room condition for 24±2 hours before initial measurement.									
			<table border="1"> <thead> <tr> <th>步骤 (Step)</th> <th>①</th> <th>②</th> <th>③</th> <th>④</th> <th>⑤</th> </tr> </thead> <tbody> <tr> <td>温度 (Temp.)</td> <td>20±2℃</td> <td>-25±2℃</td> <td>20±2℃</td> <td>85±2℃</td> <td>20±2℃</td> </tr> </tbody> </table>	步骤 (Step)	①	②	③	④	⑤	温度 (Temp.)	20±2℃	-25±2℃
步骤 (Step)	①	②	③	④	⑤							
温度 (Temp.)	20±2℃	-25±2℃	20±2℃	85±2℃	20±2℃							

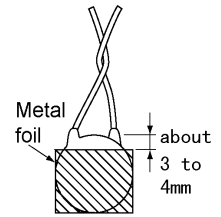

项 目 ITEM	规 格 SPECIFICATION		试 验 方 法 及 条 件 TEST METHOD AND CONDITION																
9. 端子强度 Strength of Lead Wires (c 式不做此 项 Type c none)	抗拉强度 Pull	导线不断裂 电容器不破损 Lead wire shall not cut off and capacitor shall not be damaged	把制品固定,在端子引出方向施加负荷 10N 保持 10±1 秒。 Fix the body of the capacitor and apply a tensile weight gradually to each lead wire in the radial direction of capacitor up to 10N, and keep it for 10±1sec. 																
	弯曲强度 Bending		在端子间施加 5N 负荷并弯曲 90°, 回复原后反向弯曲 90°, 每次弯曲时间为 2 至 3 秒, 连续 2 次。 Each lead wire shall be subjected to 5N weight and then a 90° bend, at the point of egress, in one direction return to original position, and then a 90° bend in the opposite direction at the rate of one bend in 2-3 s for 2times.																
10. 耐焊接热 Soldering Effect	外观 Appearance	无显著异常 No marked defect	将端子浸入温度为 260±5℃ 的熔锡内, 外保留 1.5-2.0mm 距离主体边缘, 并保持 5.0±0.5 秒。 试验前: 电容器应放置在 85±2℃ 的温度下 1 小时, 然后在常温下恢复 24±2 小时后测试。																
	容量变化 Capacitance Change	±10%max	试验后: 室内条件下恢复 24±2 小时。 The lead wires shall be immersed into the melted solder of 260±5℃ up to about 1.5 to 2.0 mm from the main body for 5.0±0.5 sec. Pre-treatment: The capacitor shall be placed at 85±2℃ for 1 hour, then placed at room condition for 24±2 hours before initial measurement. Post-treatment: Capacitor shall be stored for 24±2 hours at room condition. 																
11. 温度循环 Temp. Cycling	外观 Appearance	无显著异常 No marked defect	将电容器放入高低温箱, 按下列步骤循环 5 次。 试验前: 电容器应放置在 85±2℃ 的温度下 1 小时, 然后在常温下恢复 24±2 小时后测试。 试验后: 在室内条件下恢复 24±2 小时测试。																
	容量变化 Capacitance Change	±10%max	The capacitor shall be introduced into the test chamber, and shall be exposed to the temperature conditions as shown in table at 5 cycles. pre-treatment: The capacitor shall be placed at 85±2℃ for 1 hour, then placed at room condition for 24±2 hours before initial measurement. Post-treatment: Capacitor shall be stored for 24±2 hours at room conditions.																
<table border="1" style="width: 100%; border-collapse: collapse; text-align: center;"> <tr> <td>步骤(STEP)</td> <td>1</td> <td>2</td> <td>3</td> <td>4</td> </tr> <tr> <td>温度(TEMP.)</td> <td>-25±3℃</td> <td>20±2℃</td> <td>85±3℃</td> <td>20±2℃</td> </tr> <tr> <td>时间(TIME)</td> <td>30±3min.</td> <td>3min. max</td> <td>30±3min.</td> <td>3min. max</td> </tr> </table>					步骤(STEP)	1	2	3	4	温度(TEMP.)	-25±3℃	20±2℃	85±3℃	20±2℃	时间(TIME)	30±3min.	3min. max	30±3min.	3min. max
步骤(STEP)	1	2	3	4															
温度(TEMP.)	-25±3℃	20±2℃	85±3℃	20±2℃															
时间(TIME)	30±3min.	3min. max	30±3min.	3min. max															
12. 耐振性 Vibration Resistance	外观 Appearance	无显著异常 No marked defect	电容器须焊锡固定好, 固定点距电容器主体 3±1.0mm, 并经 10Hz→500Hz 之振动频率, 全振幅 1.5mm, 振动时间为 6 小时, 往 X、Y、Z 轴三个方向(各 2 小时)。 试验前: 电容器应放置在 85±2℃ 的温度下 1 小时, 然后在常温下恢复 24±2 小时后测试。 试验后: 在室内条件下恢复 24±2 小时测试。																
	容量变化 Capacitance Change	±10%max	The capacitor shall firmly be soldered to the supporting lead wires about 3±1.0 mm from the body of the capacitor and vibration which is 10 to 500Hz in the vibration frequency range, 1.5mm in total amplitude, for a total of 6 hours, 2 hours each in three mutually perpendicular directions. pre-treatment: The capacitor shall be placed at 85±2℃ for 1 hour, then placed at room condition for 24±2 hours before initial measurement. Post-treatment: Capacitor shall be stored for 24±2 hours at room conditions. 																
13. 易焊性 Solder ability of lead wires	导线上沾锡面积大于 90%。 Lead wire shall be soldered with uniformly coated on the axial direction over 90% of the circumferential direction.		导线须浸入助焊剂后再浸入 245±5℃ 的熔锡内, 距离主体 2.0~2.5mm, 时间 2±0.5 秒。 The lead wires of the capacitor shall be dipped into a alcohol solution of 25% wt rosin and then into molten solder of 245±5℃ for 2±0.5 sec. In both case the depth of dipping is up to about 2.0 to 2.5 mm from the root of the lead wires.																

项 目 ITEM	规 格 SPECIFICATION		试 验 方 法 及 条 件 TEST METHOD AND CONDITION
14. 碰撞试验 Collision Resistance	外观 Appearance	无显著异常 No marked defect	电容器须焊锡固定好, 固定点距电容器主体 3 ± 1.0 mm, 并施加一加速度为 390m/s^2 , 脉冲时间为 6ms 的碰撞, 次数为 4000 次。 试验前: 电容器应放置在 $85 \pm 2^\circ\text{C}$ 的温度下 1 小时, 然后在常温下恢复 24 ± 2 小时后测试。 试验后: 在室内条件下恢复 24 ± 2 小时测试。 The capacitor shall firmly be soldered to the supporting lead wire about 3 ± 1.0 mm from the body of the capacitor and a collision which is 390m/s^2 in the acceleration, 6ms in the pulse cycle for 4000 times. pre-treatment: The capacitor shall be placed at $85 \pm 2^\circ\text{C}$ for 1 hour, then placed at room condition for 24 ± 2 hours before initial measurement. Post-treatment: Capacitor shall be stored for 24 ± 2 hours at room conditions.
	容量变化 Capacitance Change	$\pm 10\%$ max	
15. 湿热循环 Humidity Cycling	外观 Appearance	无显著异常 No marked defect	电容器在温度 $40 \pm 2^\circ\text{C}$, 湿度 $95 \pm 3\%$ RH 下放置 8 小时, 室温下放置 16 小时, 循环 5 次。 试验后: 在室内条件下恢复 1 至 2 小时。 Set the capacitor for 8 hours at $40 \pm 2^\circ\text{C}$ in $95 \pm 3\%$ RH, then placed at room condition for 16 hours, circulating for 5 times. Post-treatment: The capacitor shall be stored for 1 to 2 hours at room condition.
	容量变化 Capacitance Change	$\pm 10\%$ max	
	损耗因数 D. F.	0.6%max	
	绝缘电阻 I. R.	大于 $2500\text{M}\Omega$ $2500\text{M}\Omega_{\text{min}}$	
16. 耐湿性 Humidity (Under Steady State)	外观 Appearance	无显著异常 No marked defect	电容器在温度 $40 \pm 2^\circ\text{C}$, 湿度 $95 \pm 3\%$ RH 下放置 500 ± 12 小时。 试验前: 电容器应放置在 $85 \pm 2^\circ\text{C}$ 的温度下 1 小时, 然后在常温下恢复 24 ± 2 小时后测试。 试验后: 在室内条件下恢复 24 ± 2 小时。 Set the capacitor for 500 ± 12 hours at $40 \pm 2^\circ\text{C}$ in $95 \pm 3\%$ RH. pre-treatment: The capacitor shall be placed at $85 \pm 2^\circ\text{C}$ for 1 hour, then placed at room condition for 24 ± 2 hours before initial measurement. Post-treatment: The capacitor shall be stored for 24 ± 2 hours at room condition.
	容量变化 Capacitance Change	$\pm 10\%$ max	
	损耗因数 D. F.	0.6%max	
	绝缘电阻 I. R.	大于 $2500\text{M}\Omega$ $2500\text{M}\Omega_{\text{min}}$	