

客户 (Customer) : \_\_\_\_\_

承认书

Approval Sheet

谨致执事者：兹提供敝公司之有关详细规格及图面数据, 敬请给予办理试认定手续。  
同时敬请送返一份附有贵公司签认之测试认定后之样品承认书。

We are pleased in sending you herewith on specification and drawings for your approval.  
Please return to us one copy "Approval sheet" with your approved signature.

型号 (Model No.) : A-SP1123SR6AGHB1C-B01-3C

发文日期 (Issue Date) : 2023/07/31 承认日期 (Approved Date) : \_\_\_\_\_

Checking signature of Amicc Approval signature of customer

Designer	Checker	Approver

Designer	Checker	Approver

江苏欧密格光电科技股份有限公司  
Jiangsu Amicc Opto-Electronics Technology Co., Ltd.  
地址: 江苏省常州市武进区武南中路 98 号  
Add: 98.Wu Nan Road, Wujin, Changzhou city, Jiangsu Province  
TEL: 0086-519-89806999  
FAX: 0086-519-86523668

## Multi-Color Type ■Side view Package

### A-SP1123SR6AGHB1C-B01-3C

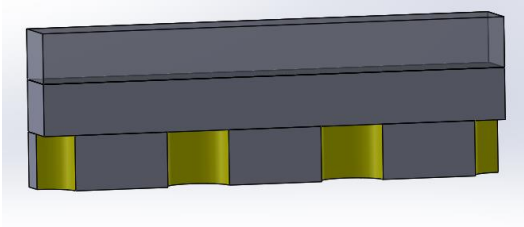

#### Features

- Side view package
- Side view LED
- Compatible with infrared and vapor phase reflow solder process.
- Wide viewing angle
- Pb-free
- RoHS compliant.
- Moisture sensitivity level 2

#### Description

The Amicc1123S package has high efficacy, high power consumption, wide viewing angle and a compact form factor. These features make this package an ideal LED for all lighting applications.

#### Applications

- General lighting
- Decorative and Entertainment Lighting
- Indicators
- AutomotiveTelecommunication
- Switch lights

#### Device Selection Guide

Type	Chip Materials	Emitted Color	Resin Color
R6A	AlGaInP	Red	Water Clear
GH	InGaN	Green	
B1	InGaN	Blue	

**Absolute Maximum Ratings (T<sub>Soldering</sub>=25°C)**

Parameter	Symbol	Color	Rating	Unit
Reverse Voltage	V <sub>R</sub>		5	V
Forward Current	I <sub>F</sub>	R6A	25	mA
		GH	20	mA
		B1	20	mA
Peak Forward Current (Duty 1/10 @1ms)	I <sub>FP</sub>	R6A	90	mA
		GH	60	
		B1	60	
Power Dissipation	P <sub>d</sub>	R6A	60	mW
		GH	75	
		B1	75	
Electrostatic Discharge(HBM)	ESD	R6A	2000	V
		GH	1000	
		B1	1000	
Operating Temperature	T <sub>opr</sub>		-40~+85	°C
Storage Temperature	T <sub>stg</sub>		-40~+100	°C
Soldering Temperature	T <sub>sol</sub>		Reflow Soldering : 260 °C for 10 sec. Hand Soldering : 350 °C for 3 sec.	

Note:

The products are sensitive to static electricity and must be carefully taken when handling products.

**Electro-Optical Characteristics (T<sub>Soldering</sub>=25°C)**

Parameter	Symbol	Color	Min.	Typ.	Max.	Unit	Condition
Luminous Intensity	I <sub>v</sub>	R6A	180	-----	360	mcd	I <sub>F</sub> =10mA
		GH	360	-----	715		
		B1	90	-----	180		
Peak Wavelength	λ <sub>p</sub>	R6A	-----	632	-----	nm	I <sub>F</sub> =10mA
		GH	-----	518	-----		
		B1	-----	464	-----		
Dominant Wavelength	λ <sub>d</sub>	R6A	-----	622	-----	nm	I <sub>F</sub> =10mA
		GH	520	-----	535		
		B1	465	-----	475		
Forward Voltage	V <sub>F</sub>	R6A	1.6	-----	2.3	V	I <sub>F</sub> =10mA
		GH	2.5	-----	3.0		
		B1	2.6	-----	3.1		
Viewing Angle	2θ <sub>1/2</sub>	-----	-----	130	-----	deg	I <sub>F</sub> =10mA
Spectrum Radiation Bandwidth	Δλ	-----	-----	20	-----	nm	I <sub>F</sub> =10mA
Reverse Current	I <sub>R</sub>	-----	-----	-----	10	μA	V <sub>R</sub> =5V

Notes:

1. Tolerance of Luminous Intensity ±10%.
2. Tolerance of Dominant Wavelength: ±1nm
3. Tolerance of Forward Voltage : ±0.1V.

**Bin Code Description**

**R6A: Bin Range of Luminous Intensity**

Bin Code	Min.	Max.	Unit	Condition
AS1	180	225	mcd	I <sub>F</sub> =10mA
AS2	225	285		
AT1	285	360		

**GH: Bin Range of Luminous Intensity**

Bin Code	Min.	Max.	Unit	Condition
AT2	360	450	mcd	I <sub>F</sub> =10mA
AU1	450	565		
AU2	565	715		

**B1: Bin Range of Luminous Intensity**

Bin Code	Min.	Max.	Unit	Condition
AQ2	90.0	112	mcd	I <sub>F</sub> =10mA
AR1	112	140		
AR2	140	180		

Note:  
 Tolerance of Luminous Intensity: ±10%.

**Spectrum Distribution**

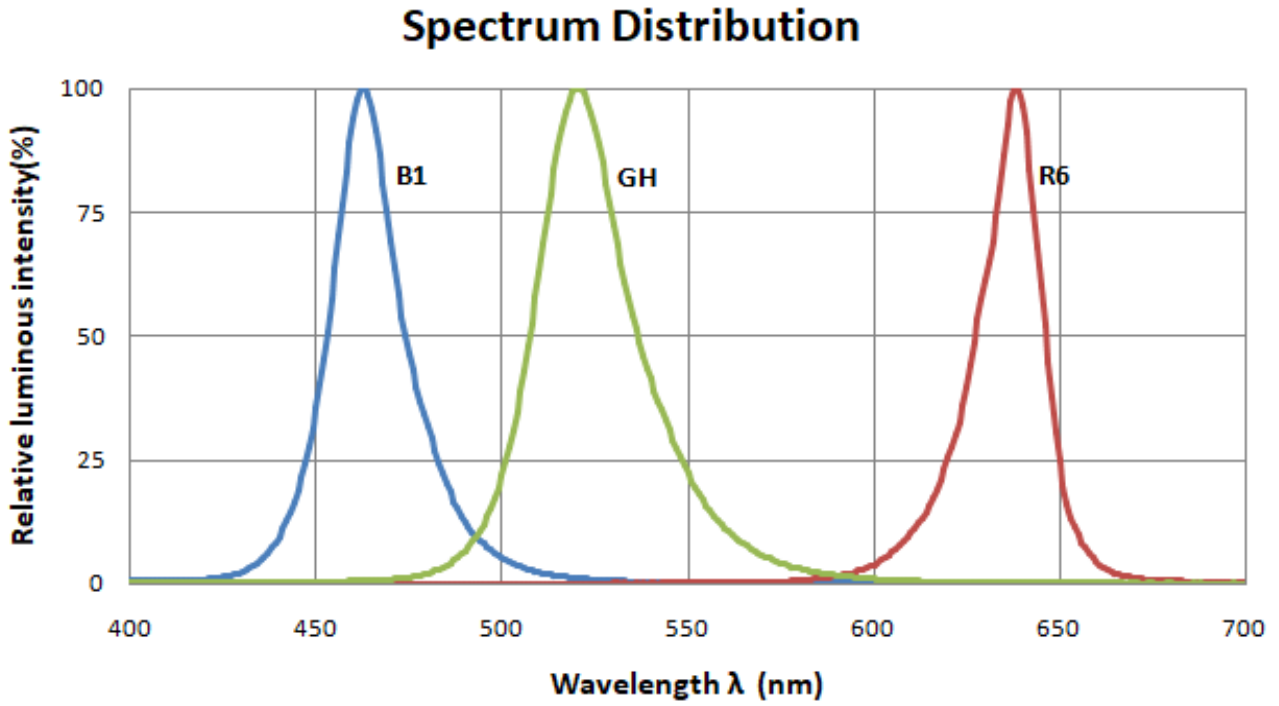

**Typical Electro-Optical Characteristics Curve (Chip code: R6A)**

Fig.1-Forward Voltage Shift vs. Junction Temperature

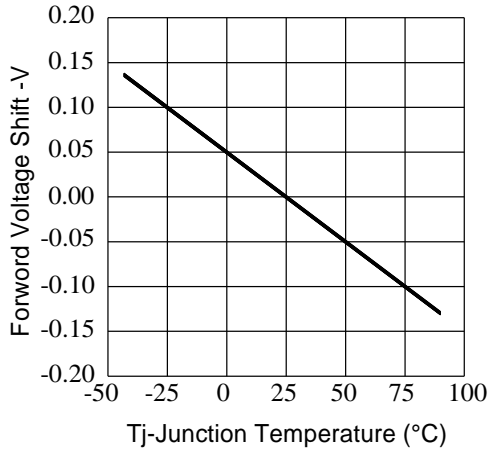

Fig.2-Relative Luminous Intensity vs. Forward Current  
 T<sub>s</sub>=25°C

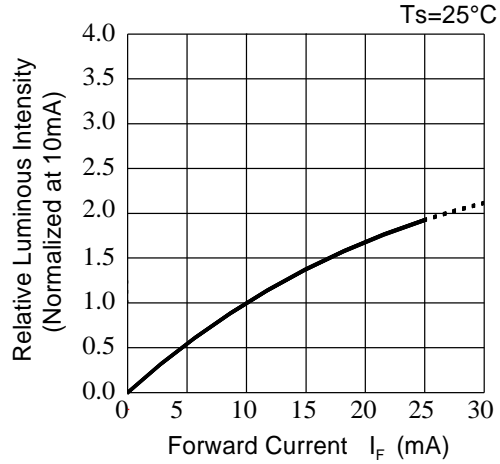

Fig.3-Relative Luminous Intensity vs. Junction Temperature

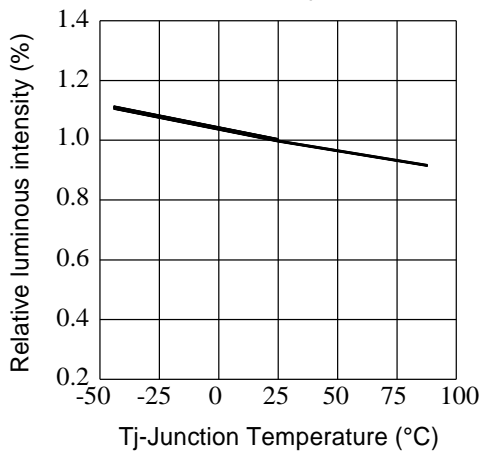

Fig.4-Forward Current vs. Forward Voltage  
 T<sub>a</sub>=25°C

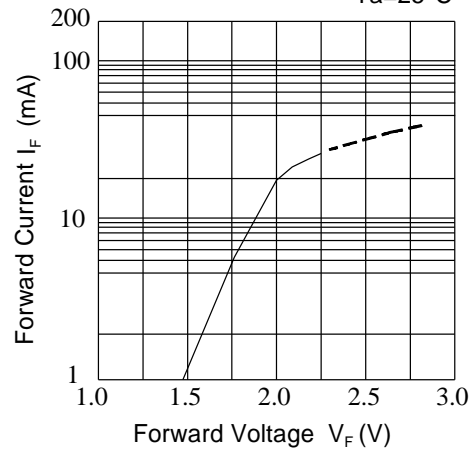

Fig.5-Max. Driving Forward Current vs. Soldering Temperature

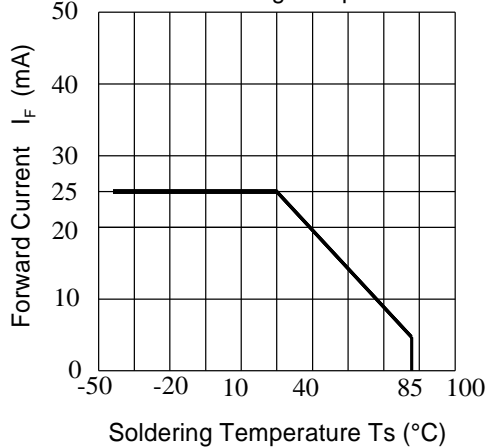
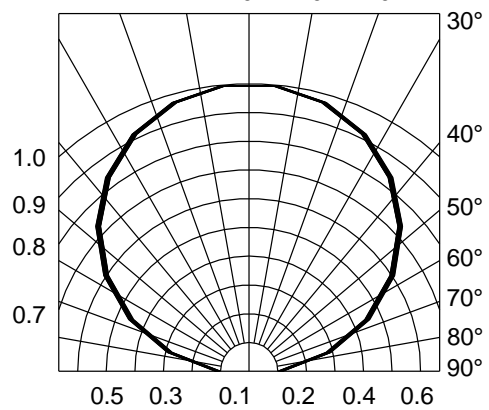

Fig.6-Radiation Diagram  
 T<sub>a</sub>=25°C



**Typical Electro-Optical Characteristics Curve (Chip code: GH/B1)**

Fig.1-Forward Voltage Shift vs. Junction Temperature

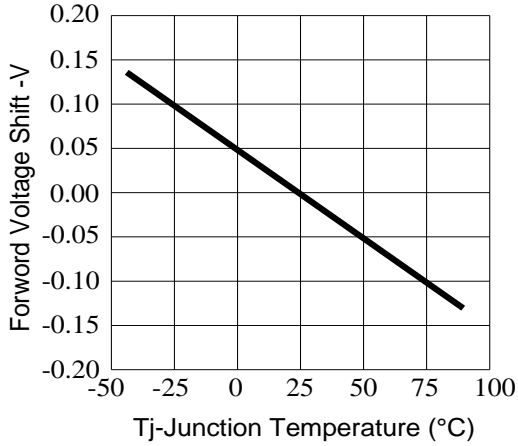

Fig.2-Relative Luminous Intensity vs. Forward Current

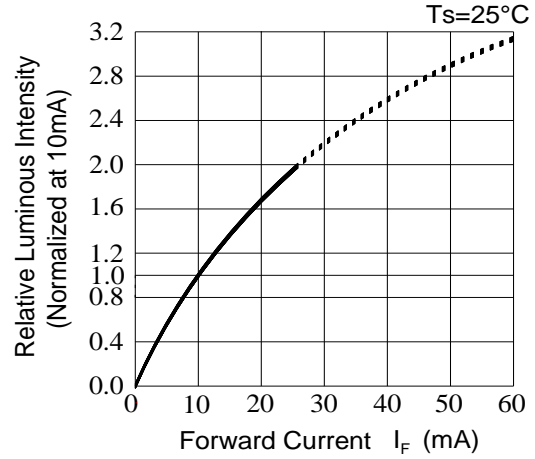

Fig.3-Relative Luminous Intensity vs. Junction Temperature

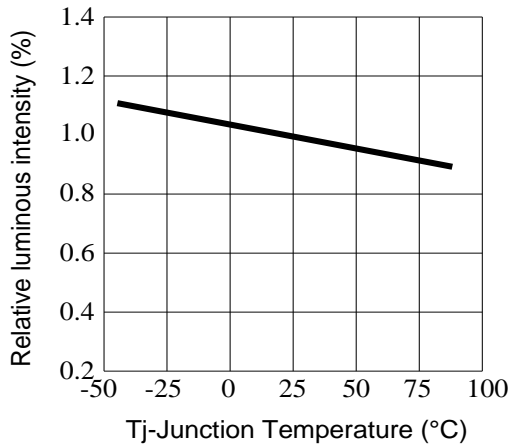

Fig.4-Forward Current vs. Forward Voltage

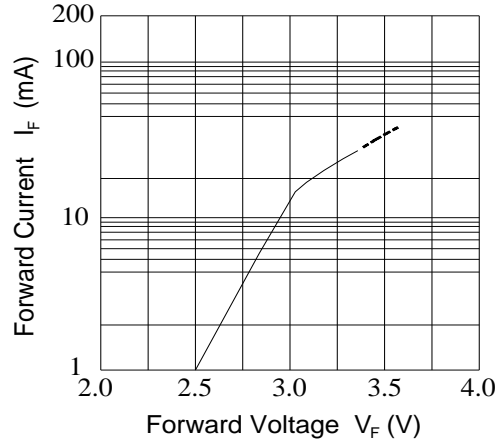

Fig.5-Max. Driving Forward Current vs. Soldering Temperature

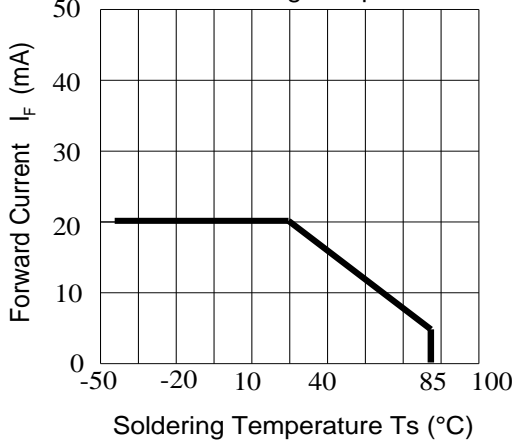
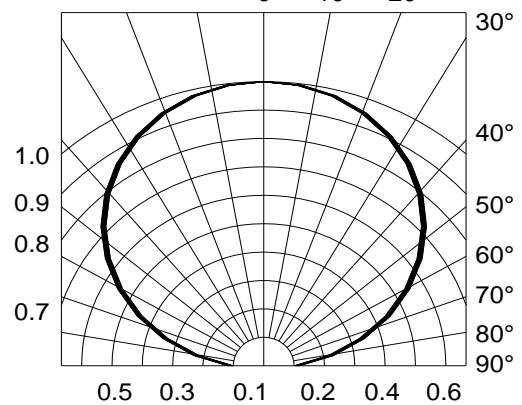
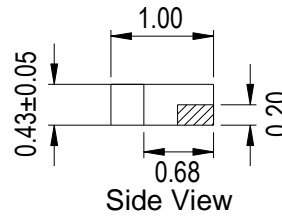
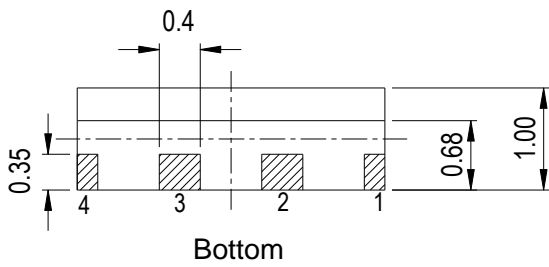
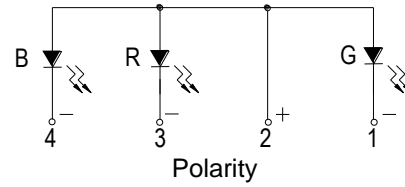
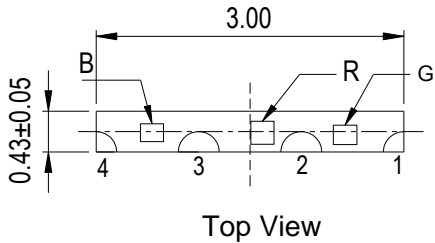

Fig.6-Radiation Diagram





**Package Dimension**



Recommended Solder Pad

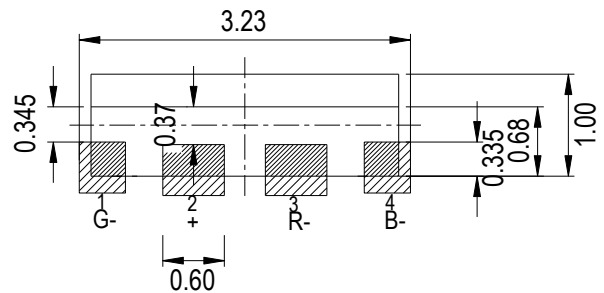
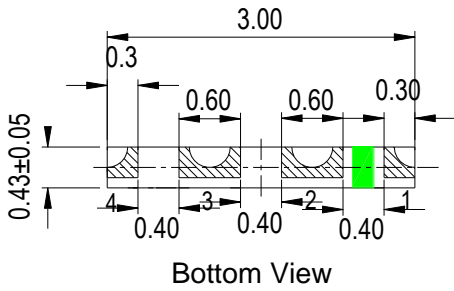

Note:  
 Tolerance unless mentioned is  $\pm 0.1\text{mm}$ , Unit = mm.

**Moisture Resistant Packing Materials**

**Label Explanation**

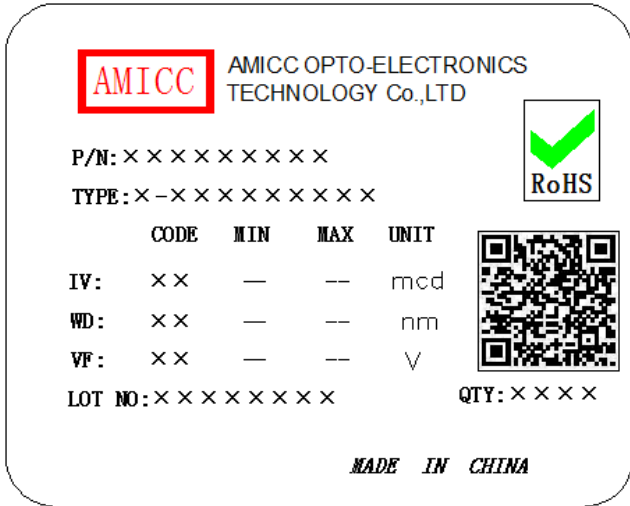

- CPN: Customer's Product Number
- P/N: Product Number
- TYPE :Part NO.
- IV: Luminous Intensity Rank
- WD: Dom. Wavelength Rank
- VF: Forward Voltage Rank
- LOT NO.: Lot Number
- QTY: Packing Quantity

**Reel Dimensions**

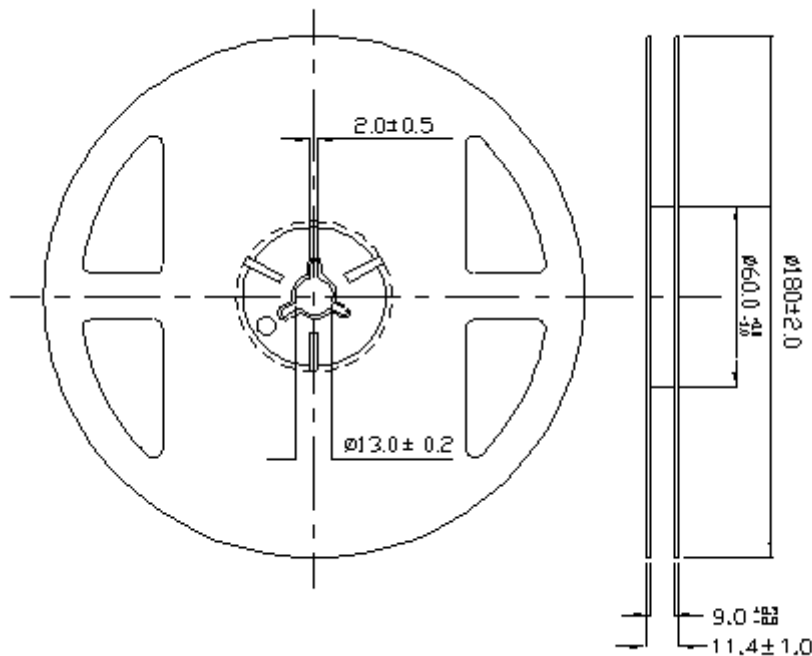

Note:  
 Tolerances unless mentioned  $\pm 0.1\text{mm}$ , Unit = mm.

Carrier Tape Dimensions: Loaded Quantity 3000 pcs Per Reel

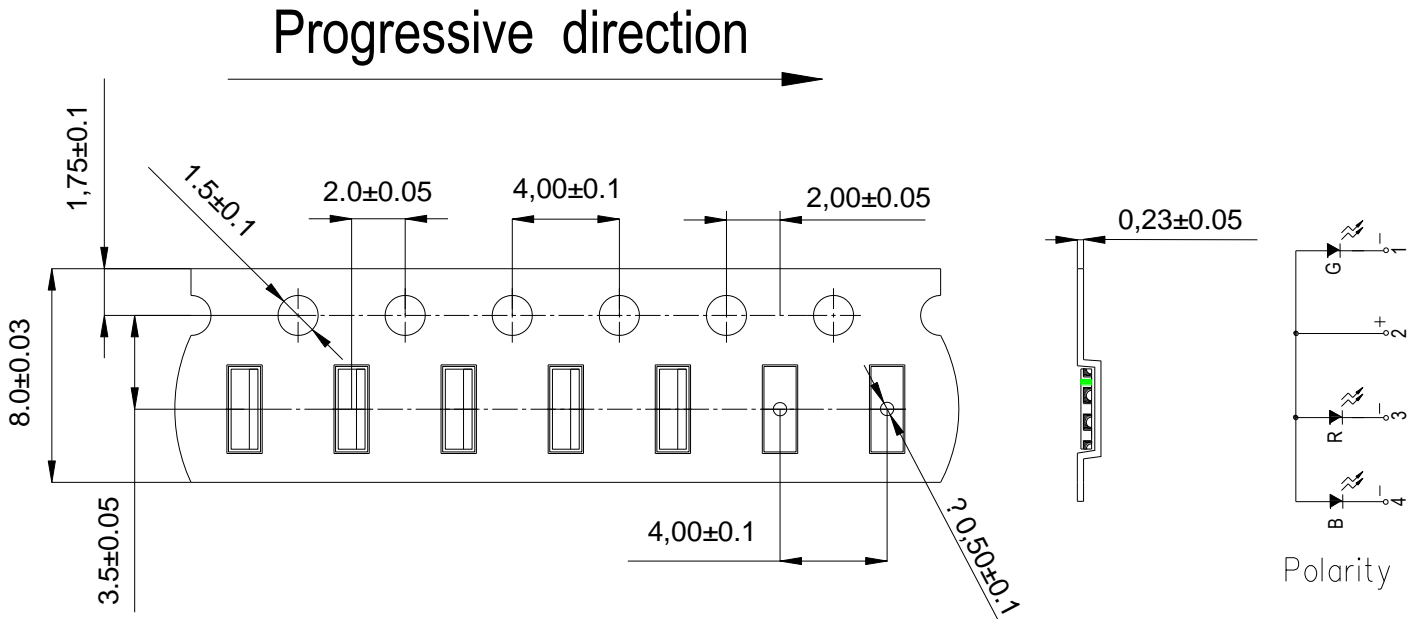

- Note:
1. Tolerance unless mentioned is  $\pm 0.1$  mm, Unit = mm.
  2. Minimum packing amount is 1000 pcs per reel.

**Moisture Resistant Packing Process**

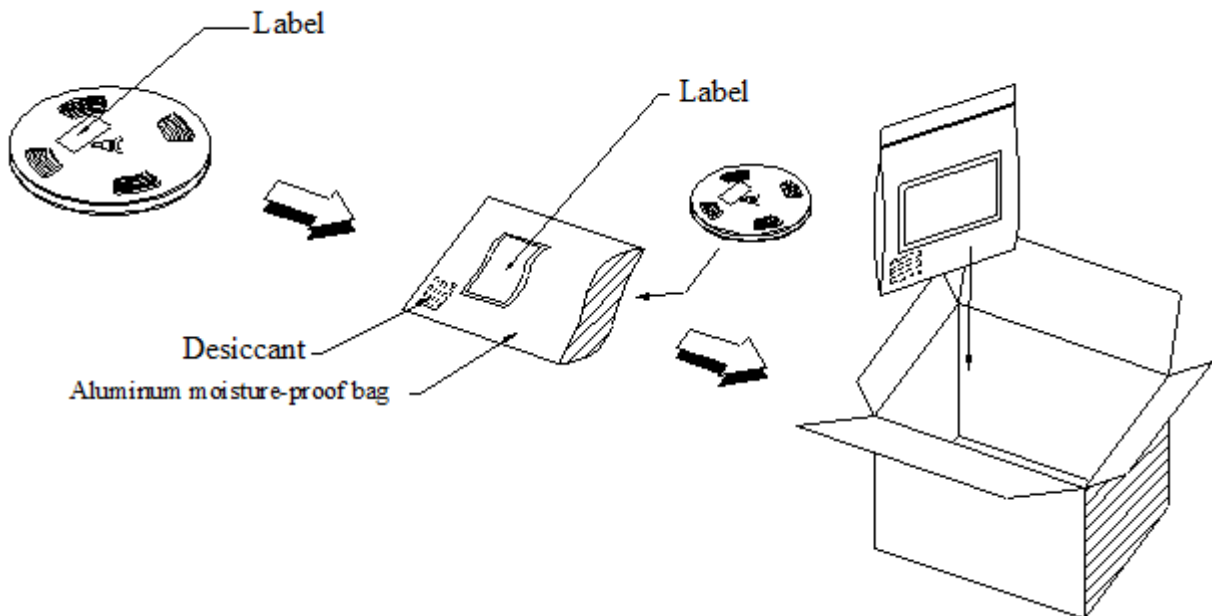

## Reliability Test Items and Conditions

The reliability of products shall be satisfied with items listed below.

Confidence level : 90%

LTPD : 10%

No.	Items	Test Condition	Test Hours/Cycles	Sample Size	Ac/Re
1	Reflow Soldering	Temp. : 260°C/10sec.	6 Min.	22 PCS.	0/1
2	Thermal Shock	H : +100°C 5min ∫ 10 sec L : -10°C 5min	300 Cycles	22 PCS.	0/1
3	Temperature Cycle	H : +100°C 15min ∫ 5 min L : -40°C 15min	300 Cycles	22 PCS.	0/1
4	High Temperature/Humidity	Ta=85°C,85%RH	1000 Hrs.	22 PCS.	0/1
5	Low Temperature Storage	Ta=-40°C	1000 Hrs.	22 PCS.	0/1
6	High Temperature Storage	Ta=100°C	1000 Hrs.	22 PCS.	0/1
7	DC Operation Life	Ta=25°C, I <sub>F</sub> = 10 mA	1000 Hrs.	22 PCS.	0/1

## Precautions for Use

### 1. Over-current-proof

Customer must apply resistors for protection; otherwise slight voltage shift will cause big current change (Burn out will happen).

### 2. Storage

2.1 Do not open moisture proof bag before the products are ready to use.

2.2 Before opening the package: The LEDs should be kept at 30°C or less and 90%RH or less.

2.3 After opening the package: The LED's floor life is 1 year under 30°C or less and 60% RH or less. If unused LEDs remain, it should be stored in moisture proof packages.

2.4 If the moisture absorbent material (silica gel) has faded away or the LEDs have exceeded the storage time, baking treatment should be performed using the following conditions.

Baking treatment: 60±5°C for 24 hours.

### 3. Soldering Condition

#### 3.1 Pb-free solder temperature profile

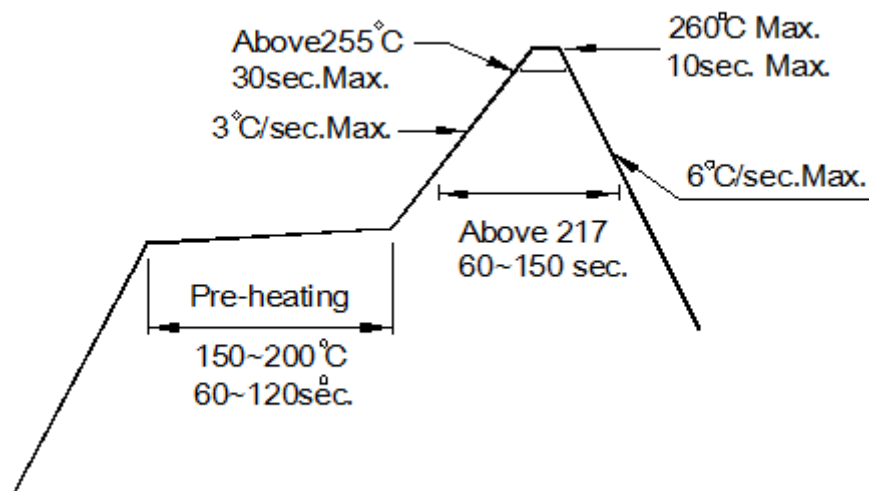

3.2 Reflow soldering should not be done more than two times.

3.3 When soldering, do not put stress on the LEDs during heating.

3.4 After soldering, do not warp the circuit board.

#### 4. Soldering Iron

Each terminal is to go to the tip of soldering iron temperature less than 350°C for 3 seconds within once in less than the soldering iron capacity 25W. Leave two seconds and more intervals, and do soldering of each terminal. Be careful because the damage of the product is often started at the time of the hand solder.

#### 5. Repairing

Repair should not be done after the LEDs have been soldered. When repairing is unavoidable, a double-head soldering iron should be used (as below figure). It should be confirmed beforehand whether the characteristics of the LEDs will or will not be damaged by repairing.

