



REV.	ECN NO.	REVISED	DATE

NOTE:

1.MATERIAL:

- a.HOUSING: High Temp Nylon+30%GF BLACK
- b.CONTACT: Stainless Steel
(SURFACE PLATING: Au 0.5u")

SEE ORDERING INFORMATION

2.ELECTRIC:

- a.CONTACT RESISTANCE: 30 MILLIOHMS MAX
- b.INSULATION RESISTANCE: 100 MEGA OHMS MIN
- c.DIELECTNIC VOLTAGE: 500V AC ONE MINUTE
- d.OPERATING TEMPERATURE: -10°C~ +100°C

ORDERING INFORMATION

BH-123A-B5BA003

电池盒

电池型号

SMT 180° TYPE

PLATING:
A-Au1U"
J-Ni100U"~120U"
K-Sn100U"~120U"

MATERIAL:
1A-PP BLACK
1B-PAG6 BLACK
2A-PPA BROWN
2B-PPA BLACK
3A-PPS BROWN
3B-PPS BLACK
4A-LCP WHITE
4B-LCP BLACK
5B-NYLON BLACK

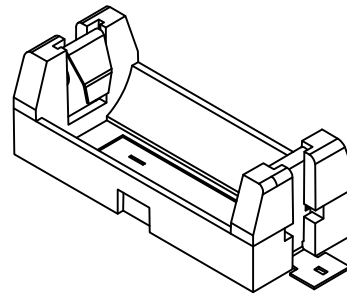

3D View

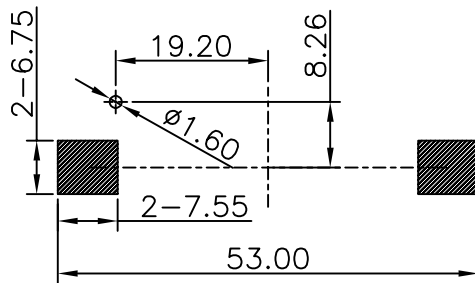
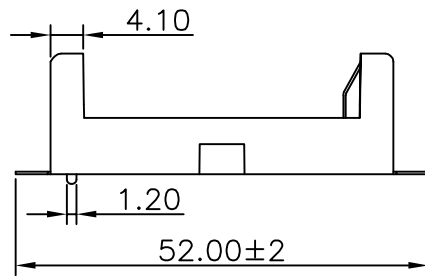
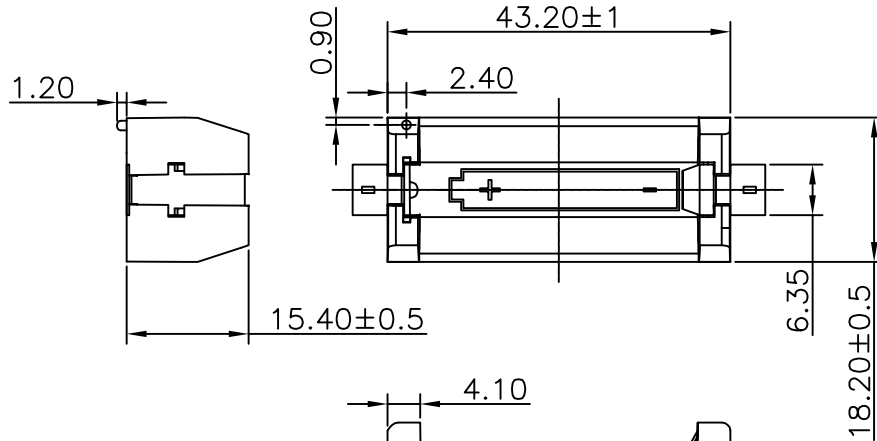

PCB Layout Diagram
Top View

UNLESS OTHERWISE SPECIFIED TOLERANCES		MYOUNG 美用 www.meiyangdz.com			
DECIMALS: X :±0.30 X.X :±0.25 X.XX :±0.20 X.XXX :±0.10	ANGLES: X :±1° X.X :±0.5°	DSND	YangFeng	DATE	2023-07-25
WEIGHT:		CHKD	ZhouRuicai	DATE	2023-07-25
SHEET 1 OF 1		APVD	XueShunyong	DATE	2023-07-25
SCALE:		SIZE: A4		VIEW:	⊕ ⊖
UNIT: mm		REV.:	A/1	OBJECT:	MY
TITLE:		电池盒BH-123A-1J Au SMT			
PART NO.:		BH-123A-B5BA003			
DRAW NO.:		WD-CP-0228			

2	TERMINAL	2	Stainless Steel,T=0.35MM	Au-Plating
1	HOUSING	1	High Temp Nylon+30%GF	BLACK
NO.	PART NAME	Q'TY	MATERIAL	PLATING & COLOR