

Description

Ultra low capacitance bidirectional ElectroStatic Discharge (ESD) protection diodes in small Surface-Mounted Device (SMD) plastic packages designed to protect one data line from the damage caused by ESD.

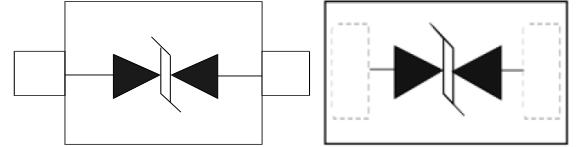

Features

- Bidirectional ESD protection of one line
- Ultra low diode capacitance: $C_d = 2.9 \text{ pF}$
- IEC 61000-4-2; level 4 (ESD)
- Ultra low leakage current: $I_{RM} = 5 \text{ nA}$
- ESD protection of up to 10 kV

Applications

- Computers and peripherals
- Audio and video equipment
- Cellular handsets and accessories
- 10/100/1000 Ethernet
- Local Area Network (LAN) equipment
- Communication systems
- Portable electronics
- Subscriber Identity Module (SIM) card protection
- FireWire
- High-speed data lines

Quick reference data

$T_{amb} = 25 \text{ }^\circ\text{C}$ unless otherwise specified.

Symbol	Parameter	Conditions	Min	Typ	Max	Unit
Per diode						
V_{RWM}	reverse standoff voltage		-	-	5	V
C_d	diode capacitance	$f = 1 \text{ MHz}; V_R = 0 \text{ V}$	-	2.9	3.5	pF

Limiting values

In accordance with the Absolute Maximum Rating System (IEC 60134).

Symbol	Parameter	Conditions	Min	Max	Unit
Per device					
T _j	junction temperature		-	150	°C
T _{amb}	ambient temperature		-65	+150	°C
T _{stg}	storage temperature		-65	+150	°C

ESD maximum ratings

Symbol	Parameter	Conditions	Min	Max	Unit	
Per diode						
V _{ESD}	electrostatic discharge voltage	IEC 61000-4-2 (contact discharge)	[1][2]	-	10	kV
		MIL-STD-883 (human body model)		-	8	kV

[1] Device stressed with ten non-repetitive ESD pulses.

[2] Measured from pin 1 to pin 2.

ESD standards compliance

Standard	Conditions
Per diode	
IEC 61000-4-2; level 4 (ESD)	> 15 kV (air); > 8 kV (contact)
MIL-STD-883; class 3 (human body model)	> 4 kV

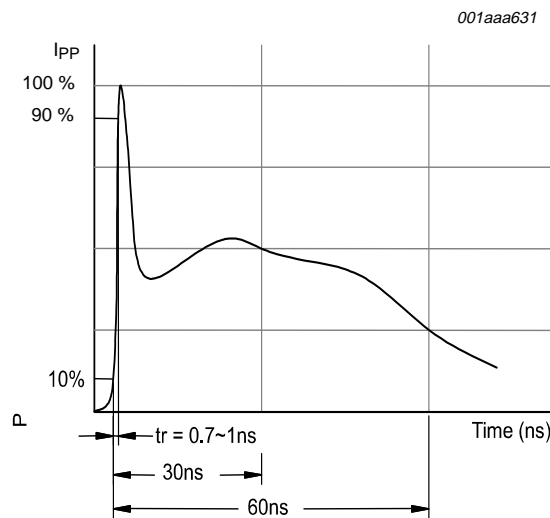
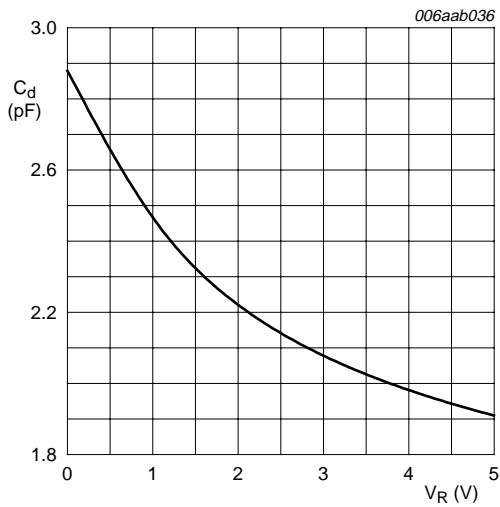

Fig 1. ESD pulse waveform according to IEC 61000-4-2

Characteristics

T_{amb} = 25 °C unless otherwise specified.

Symbol	Parameter	Conditions	Min	Typ	Max	Unit
Per diode						
V _{RWM}	reverse standoff voltage		-	-	5	V
I _{RM}	reverse leakage current	V _{RWM} = 5 V	-	5	100	nA
V _{BR}	breakdown voltage	I _R = 5 mA	5.5	7	9.5	V
C _d	diode capacitance	f = 1 MHz				
		V _R = 0 V	-	2.9	3.5	pF
		V _R = 5 V	-	1.9	-	pF
r _{dif}	differential resistance	I _R = 1 mA	-	-	100	Ω



f = 1 MHz; T_{amb} = 25 °C

Fig 2. Diode capacitance as a function of reverse voltage; typical values

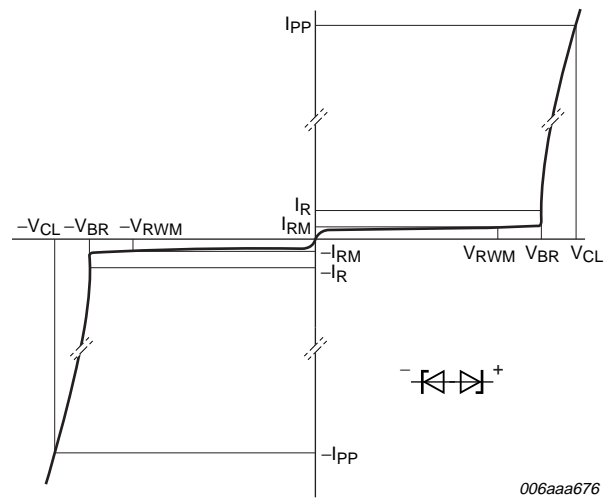
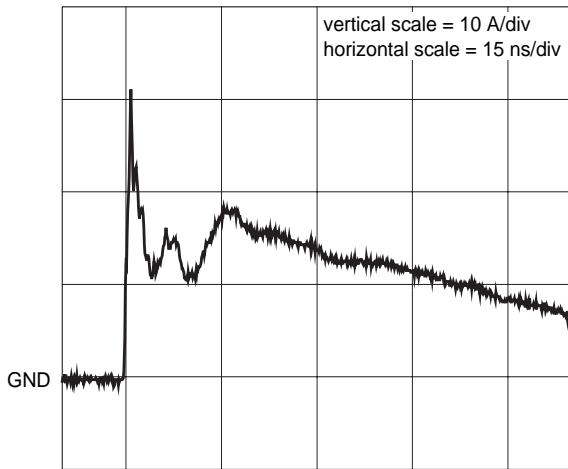
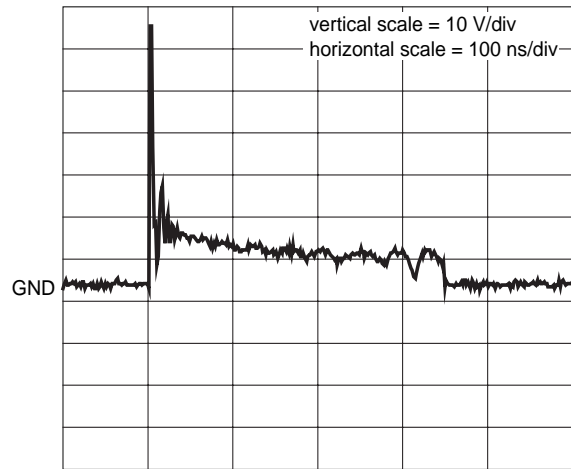

Fig 3. V-I characteristics for a bidirectional ESD protection diode



unclamped +8 kV ESD pulse waveform
(IEC 61000-4-2 network)



clamped +8 kV ESD pulse waveform
(IEC 61000-4-2 network) pin 1 to 2

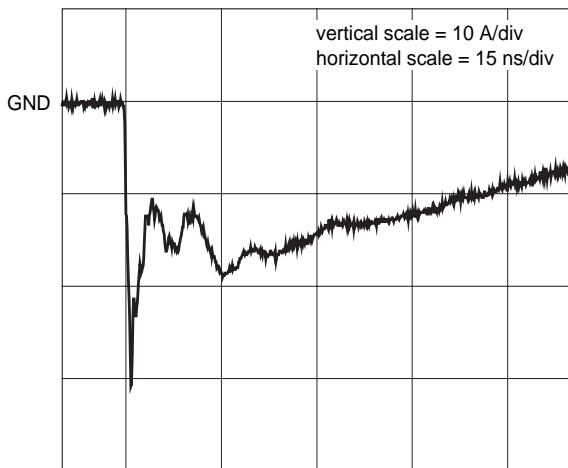

unclamped -8 kV ESD pulse waveform
(IEC 61000-4-2 network)

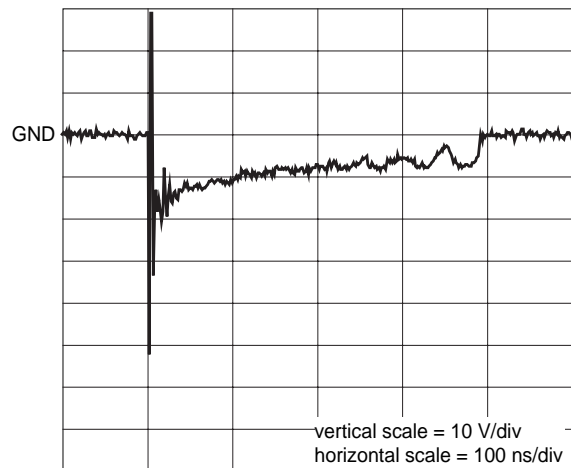

clamped -8 kV ESD pulse waveform
(IEC 61000-4-2 network) pin 1 to 2

006aab037

Fig 4. ESD clamping test setup and waveforms

SOD-323/SOD-523/SOD/882 PACKAGE OUTLINE DIMENSIONS

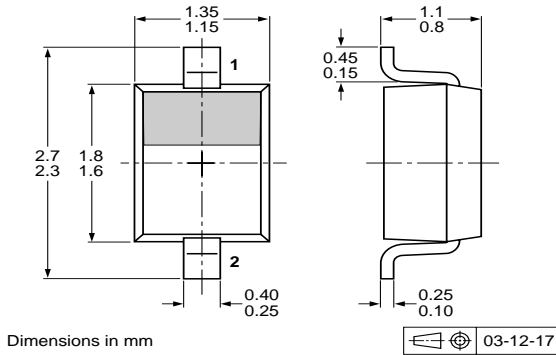

PESD5V0U1BA (SOD323)

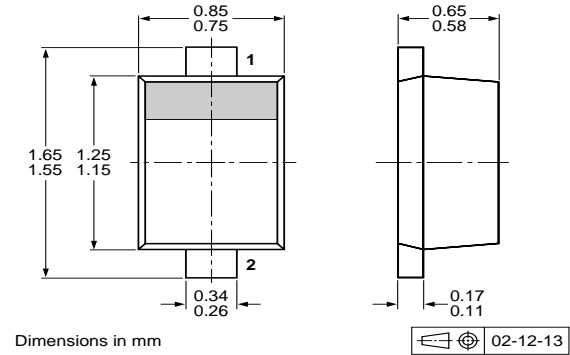

PESD5V0U1BB (SOD523)

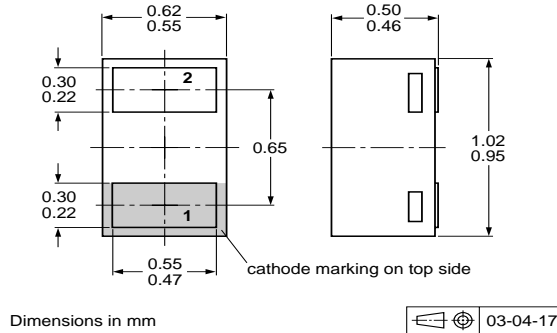

PESD5V0U1BL (SOD882)

Marking

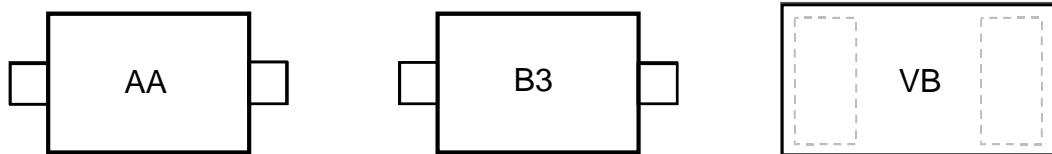

Ordering information

Order Code	Marking code	Package	Baseqty	Deliverymode
UMW PESD5V0U1BA	AA	SOD-323	10000	Tape and reel
UMW PESD5V0U1BB	B3	SOD-523	10000	Tape and reel
UMW PESD5V0U1BL	VB	SOD-882	10000	Tape and reel