

SPECIFICATION FOR APPROVAL

規 格 書

Customer (客戶名稱): _____

Customer P/N(客戶番號): _____

Our P/N (本廠番號): FS66W04100-H31

Approval Date(日期): 2020.6.18

Environment Request(環境標準):

Non-RoHS (非 RoHS 標準)

RoHS (RoHS 標準)

REACH (REACH 標準)

Others (其他)

CUSTOMER'S APPROVED SIGNATURE

--	--	--



泰州福聲電子科技有限公司

Taizhou Fusheng Electronic Technology Co.,Ltd.

Adds: No168 of FengHuang Road West,Hailing District ,Taizhou .

地址：江蘇省泰州市海陵區鳳凰西路98號

Tel: +86-523-86219066

Fax: +86-523- 81601108

[Http://www.tzfsdz.com](http://www.tzfsdz.com)

E-mail: sales@electronic-tech.cn

	DESINGER	CHECKED	APPROVED
SIGNATURE			
DATE			

Speaker Specification

Part No.	Customer No 顧客型號		Customer code 顧客編號	
	Our Part No 本廠編號	FS66W04100-H31		Revision 版本 B
No.	Item 項目	Specification 規格	Testing Condition 測試條件	
1.	Rated Imp 共稱阻抗	4ohm±15%	At 1kHz6.32Vrms	
2.	Resonance Freq 最低共振周波數	250Hz±20%	Without Baffle	
3.	Output S.P.L. 出力音壓	95±3dB	At 1m 1w 0.6,0.8,1.0,1.2KHz Average	
4.	Rated Power 定格入力	at 10.0W	at 6.32 Vrms	
5.	Max Power 最大入力	at 12.0W	at 6.93 Vrms	
6.	Frequency Range 實效頻寬	FO----20kHz		
7.	Operation 可靠性試驗	Must Be Normal at Rated Frequency Range	Program Source 10W FO ----- 10kHz	
8.	Buzzes & Rattles 異常音試驗	Should not be audible buzz and rattle at Rated Frequency Range 無異常聲	Sine Wave Between (正弦波入力) at 6.32 Vrms / FO---- 10kHz	
9.	T H D 失真	≤5%		
10.	Magnet 磁鐵	Ferrite		
11.	Operating Temperature 動作溫度	-30°C to +75°C		
12.	Storage Temperature 儲存溫度	-40°C to +85°C		
13.	Weight 重量	200g±8%		

Product Outside View

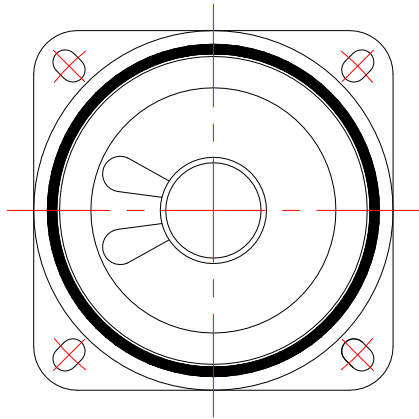
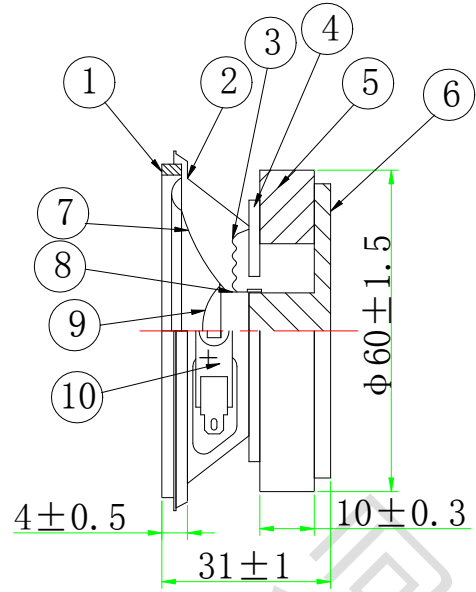
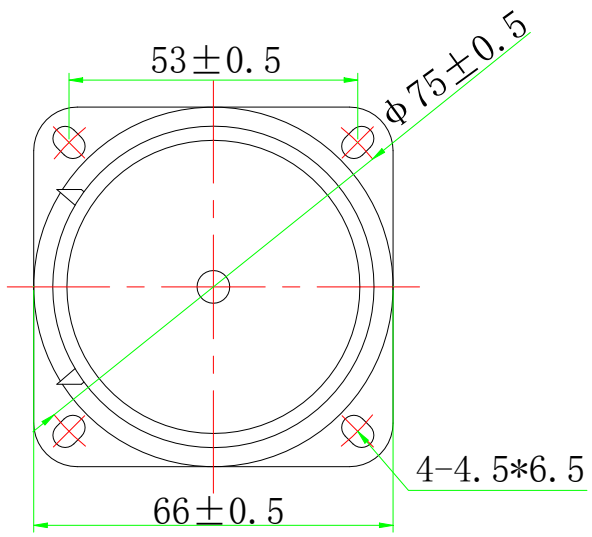

泰州福声电子科技有限公司

产品图片Picture:



Frequency Response

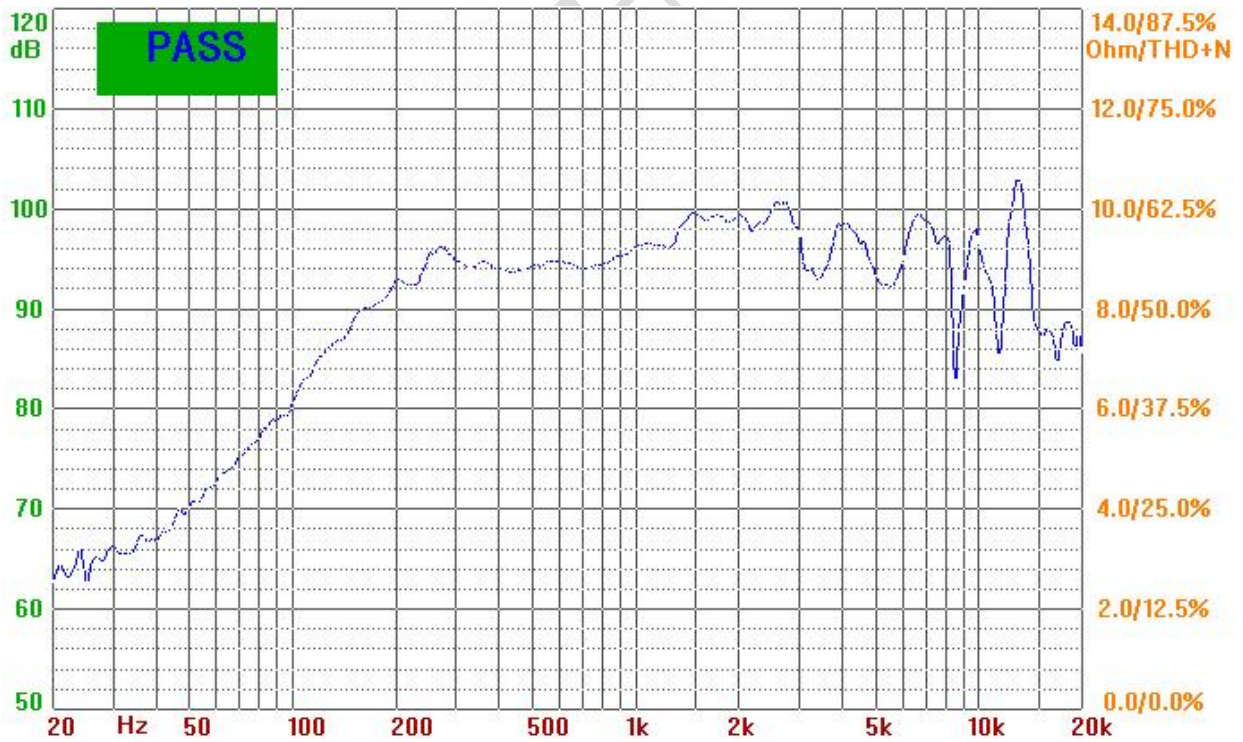

Remark

NO	零件Component	材质Material
1	压边 Gasket	纸 Paper
2	盆架 Frame	冷轧钢板SPCC
3	弹波 Damper	布 Cloth
4	华司Washer	冷轧钢板SPCC
5	磁铁 Magnet	铁氧体 Ferrite
6	T铁 T-yoke	冷轧钢板 SPCC
7	鼓纸 Cone	布边纸盆Cloth+ Paper
8	音圈 Voice coil	铝+铜 ASV+Cu
9	帽子 Dust cap	黑亮帽PET
10	接线板 Terminals	纸板+铁Paper+steel

包装Packing picture:

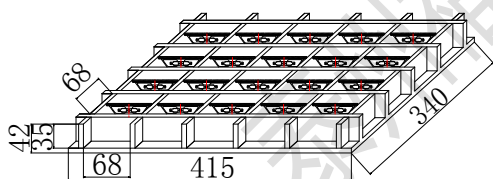

1. Each clap board 20 pcs,
each carton 3 clapboards,
60 pcs/carton
N.W: 12 KG,G.W:14 KG
4. Corrugated paper:415*340mm 1 PCS
5. Carton size:430*355*155mm 1 PCS

