

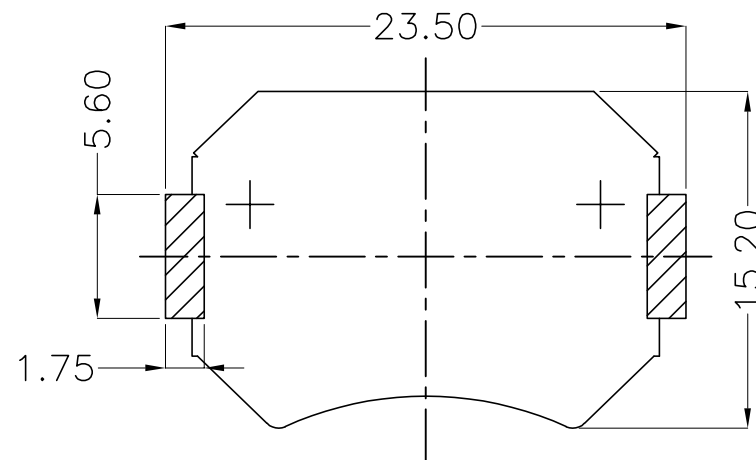

REV.	ECN NO.	REVISED	DATE

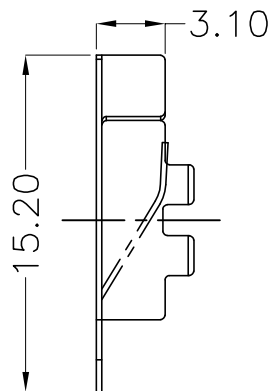

PCB Layout Diagram
Top View

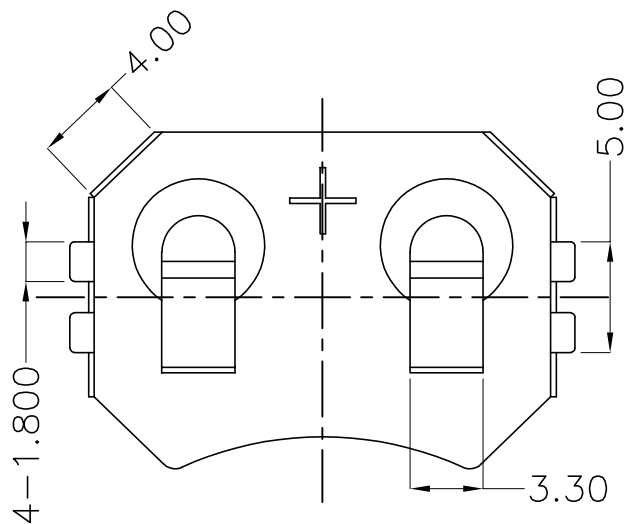
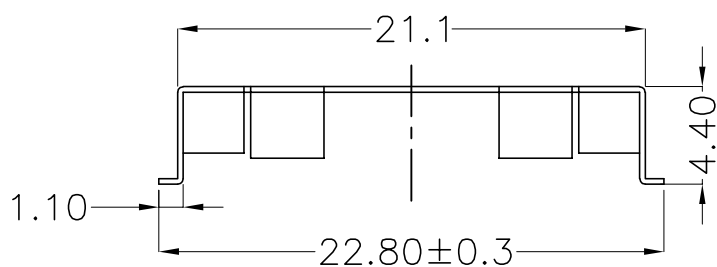

工程部
2023-11-15
H. WANG

UNLESS OTHERWISE SPECIFIED TOLERANCES		MYOUNG 美用 www.meiyangdz.com			
DECIMALS: X :±0.30 X.X :±0.25 X.XX :±0.20 X.XXX :±0.10	ANGLES: X :±1° X.X :±0.5°	DSND	WangHeng	DATE	2023-11-15
		CHKD	ZhouRuicai	DATE	2023-11-15
		APVD	XueShunyong	DATE	2023-11-15
		WEIGHT:	9	SCALE:	SIZE: A4
		SHEET 1 OF 2		VIEW:	⊙ ↺
		UNIT:	mm	REV.:	A/0
		OBJECT:		MY	
		TITLE:		电池扣CR2032-P Ni SMT 铁料 卷装	
		PART NO.:		MY-2032-08-J-Fe-R	
		DRAW NO.:		MY-CP-0379	

1	TERMINAL(+)	1	SPCC(COLD STEEL) T=0.25mm	Ni-Plating
NO.	PART NAME	Q'TY	MATERIAL	PLATING & COLOR



产品

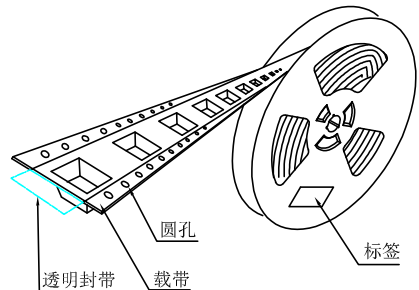

透明封带
载带

圆孔

标签

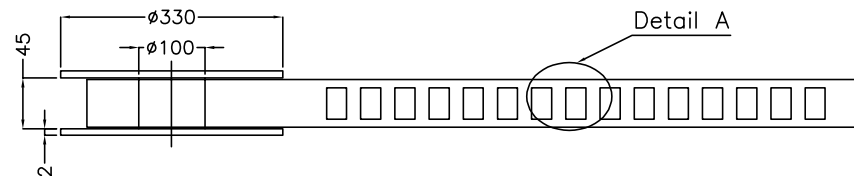

Detail A

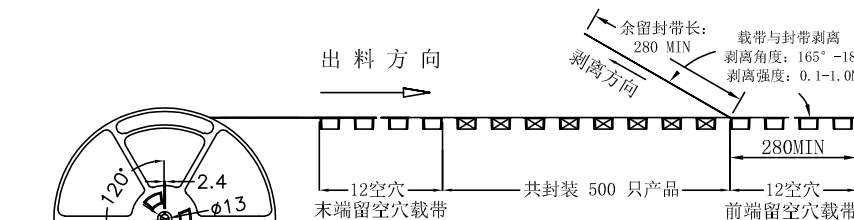

出料方向

余留封带长: 280 MIN
载带与封带剥离
剥离角度: 165° -180°
剥离强度: 0.1-1.0N

12空穴
末端留空穴载带

共封装 500 只产品

12空穴
前端留空穴载带

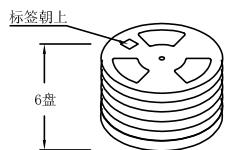
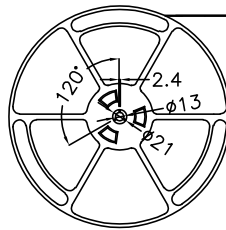

标签朝上

6盘

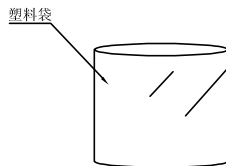

塑料袋

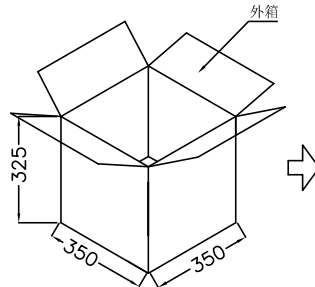

外箱

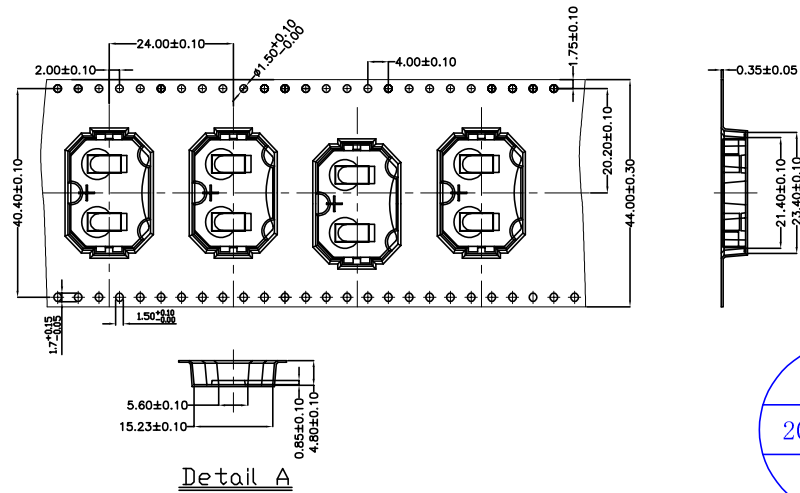
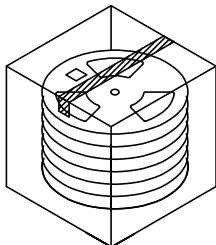

Detail A



工程部

2021-11-18

H. WANG

技术要求:

1. 圆孔十个孔距离累计允许公差为±0.2mm
2. 带长250mm内容许弯曲度1mm
3. 材料厚度以在载带边缘测量为准
4. 所有尺寸定义依循EIA-481-C系准则定义之
5. 材料: 黑色PS T=0.35mm
6. 所有卷轮为灰蓝挖空旋转塑胶卷轮
7. 整模成型长度:12.576M,
8. 非指明公差范围为: ±0.1mm;超过250mm不计算累计误差
9. 型腔外形凡未标明处倒角R为0.2-0.3; 拔模斜度未标注的为3° 以下

包装信息:

- 1、每卷盘装产品 500 只, 卷盘外侧贴相关标签;
- 2、每 6 卷盘放在一个塑料袋中;
- 3、每外箱装6盘, 产品总数: 3000 只;
- 4、外箱上下用胶纸封成“工”字;
- 5、电池扣包材CR2032-P SMT 卷装44MM(MY-2032-P-01-R)

UNLESS OTHERWISE SPECIFIED TOLERANCES		MYOUNG 美阳 www.meiyangdz.com			
DECIMALS: X : ±*** X.X : ±*** X.XX : ±*** X.XXX : ±***	ANGLES: X : ±*** X.X : ±***	DSND	WangHeng	DATE	2023-11-15
		CHKD	ZhouRuicai	DATE	2023-11-15
		APVD	XueShun Yong	DATE	2023-11-15
WEIGHT:		SCALE:	SIZE: A4	VIEW:	⊙ ⊚
SHEET 2 OF 2		UNIT: mm	REV.: A/0	OBJECT: MY	TITLE: 电池扣CR2032-P Ni SMT 铁料 卷装
		PART NO.:		MY-2032-08-J-Fe-R	
		DRAW NO.:MY-BD-0002			