

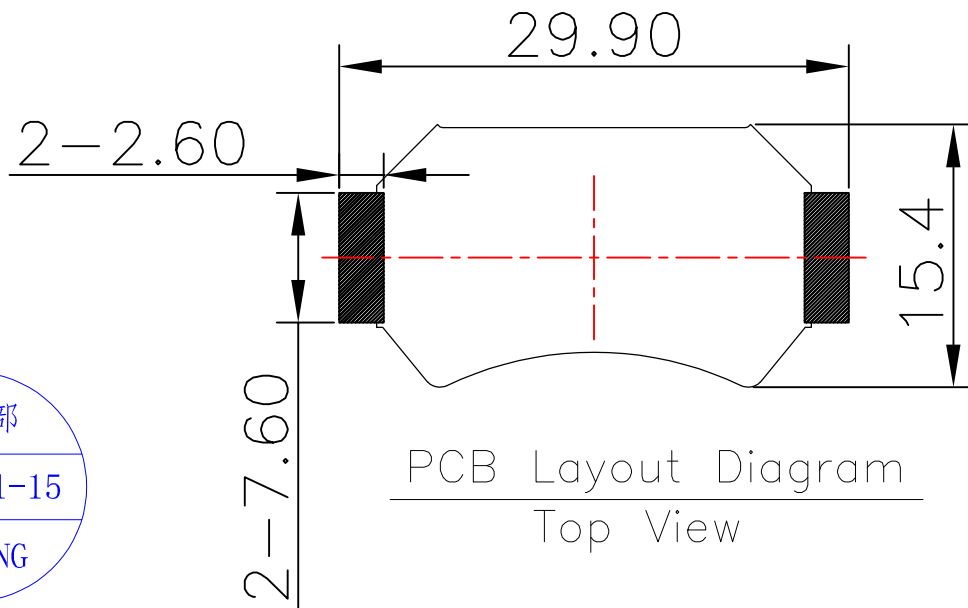

REV.	ECN NO.	REVISED	DATE

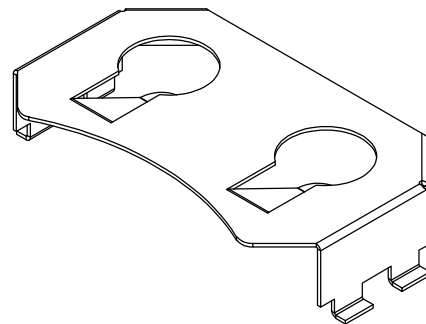
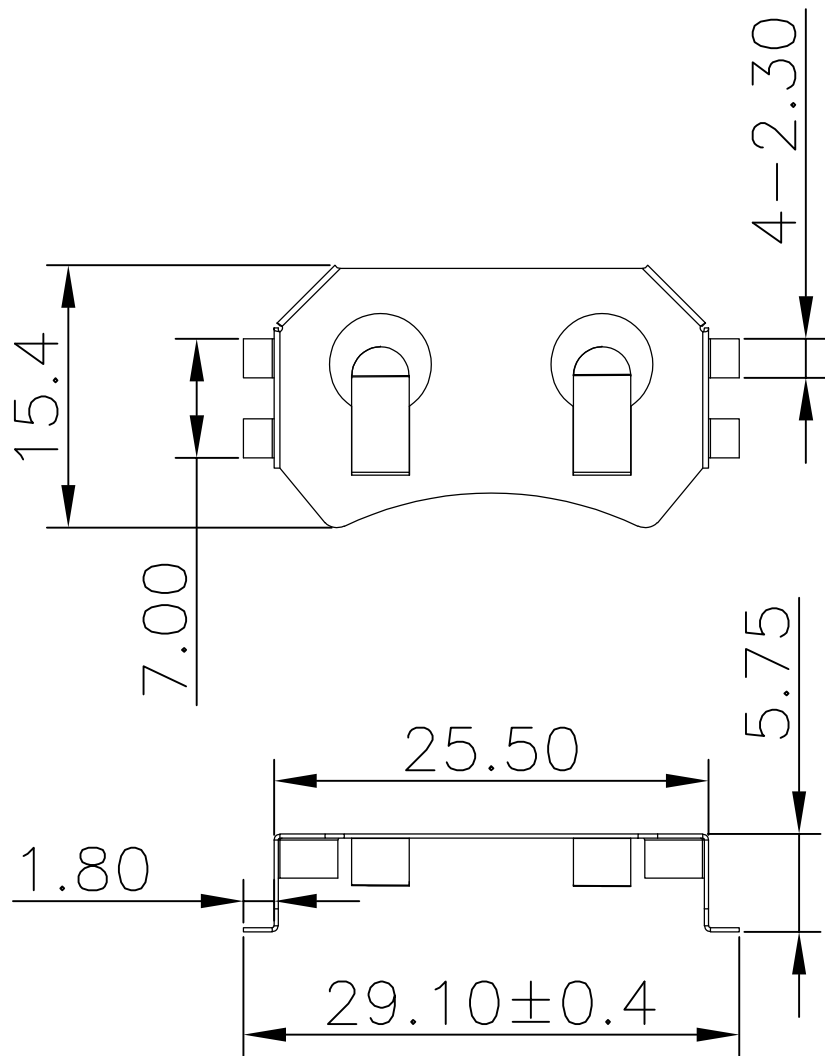

工程部  
2023-11-15  
H. WANG

UNLESS OTHERWISE SPECIFIED TOLERANCES		<b>MYOUNG 美用</b> <a href="http://www.meiyangdz.com">www.meiyangdz.com</a>			
DECIMALS: X :±0.30 X.X :±0.25 X.XX :±0.20 X.XXX :±0.10	ANGLES: X :±1° X.X :±0.5°	DSND	WangHeng	DATE	2023-11-15
WEIGHT:		CHKD	ZhouRuicai	DATE	2023-11-15
SHEET 1 OF 2		APVD	XueShunyong	DATE	2023-11-15
		SCALE:	2:1	SIZE:	A4
		UNIT:	mm	REV.:	A/0
		VIEW:	⊙ ↺	OBJECT:	MY
		TITLE:		电池扣CR2450-P SMT 卷装	
		PART NO.:		MY-2450-03-R	
		DRAW NO.:		WD-CP-0135	

1	TERMINAL(+)	1	PHOSPHOR BRONZE, T=0.25mm	Ni-Plating
NO.	PART NAME	Q'TY	MATERIAL	PLATING & COLOR

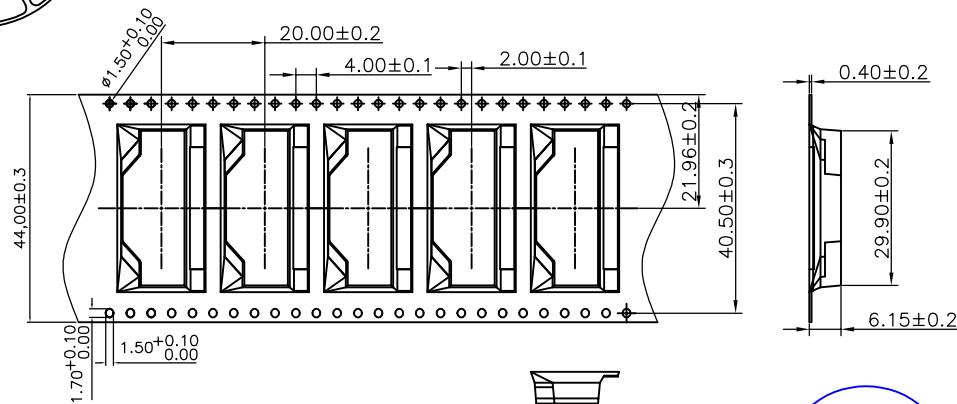
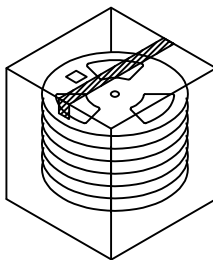
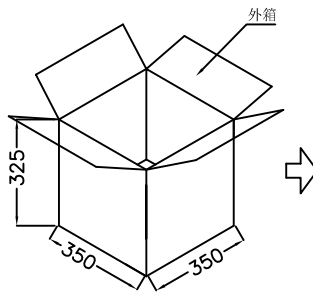
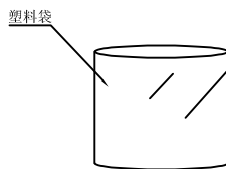
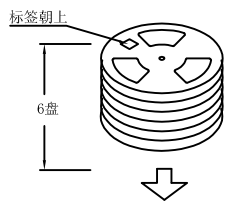
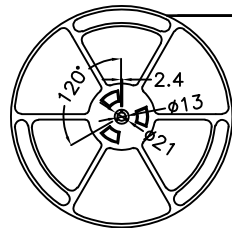
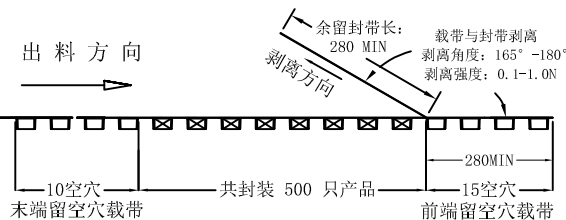
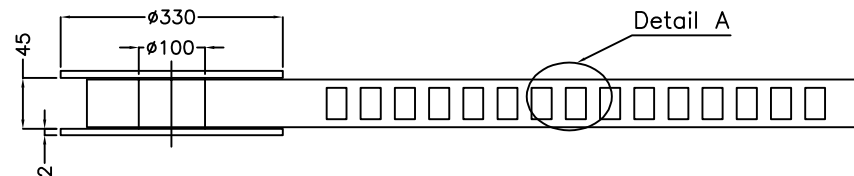
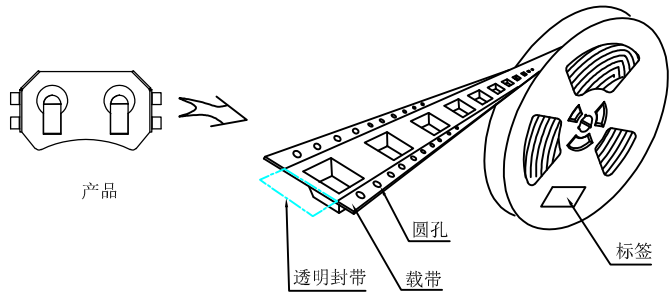

Detail A



技术要求:

1. 圆孔十个孔距离累计允许公差为±0.2mm
2. 带长250mm内容许弯曲度1mm
3. 材料厚度以在载带边缘测量为准
4. 所有尺寸定义依循EIA-481-C系准则定义之
5. 材料: 黑色PS T=0.4mm
6. 所有卷轮为灰蓝挖空旋转塑胶卷轮
7. 整模成型长度:10.5M,
8. 非指明公差范围为: ±0.1mm;超过250mm不计算累计误差
9. 型腔外形凡未标明处倒角R为0.2-0.3; 拔模斜度未标注的为3° 以下

包装信息:

- 1、每卷盘装产品 500 只, 卷盘外侧贴相关标签;
- 2、每 6 卷盘放在一个塑料袋中;
- 3、每外箱装6盘, 产品总数: 3000 只;
- 4、外箱上下用胶纸封成“工”字;
- 5、电池扣包材CR2450-P 卷装(MY-2450-P-01-R)。

UNLESS OTHERWISE SPECIFIED TOLERANCES		<b>MYOUNG 美阳</b> <a href="http://www.meiyangdz.com">www.meiyangdz.com</a>			
DECIMALS: X :±***	ANGLES: X :±***	DSND	WangHeng	DATE	2023-11-15
X.X :±***	X.X :±***	CHKD	ZhouRuicai	DATE	2023-11-15
X.XX :±***	X.X :±***	APVD	XueShun Yong	DATE	2023-11-15
X.XXX :±***	X.X :±***	WEIGHT:	SCALE:	SIZE: A4	VIEW:
SHEET 2 OF 2		UNIT: mm	REV.: A/0	OBJECT: MY	TITLE: 电池扣CR2450-P SMT 卷装
		PART NO.:		MY-2450-03-R	
		DRAW NO.:		MY-BD-0043	