

FC-SCT2010 -Series Current Sense Transformers

Sensed current up to 47 A; Designed for frequency range up to 1 MHz and above. Very low primary DC resistance 500 Vrms, one minute isolation (hipot) between windings

Core material Ferrite

Terminations RoHS compliant tin-silver over tin over nickel over phos bronze (pins 2-4); RoHS compliant matte tin over nickel over copper (pins 11-12)

Ambient temperature -40°C to $+85^{\circ}\text{C}$

Storage temperature Component: -40°C to $+125^{\circ}\text{C}$



1. Dimensions:mm

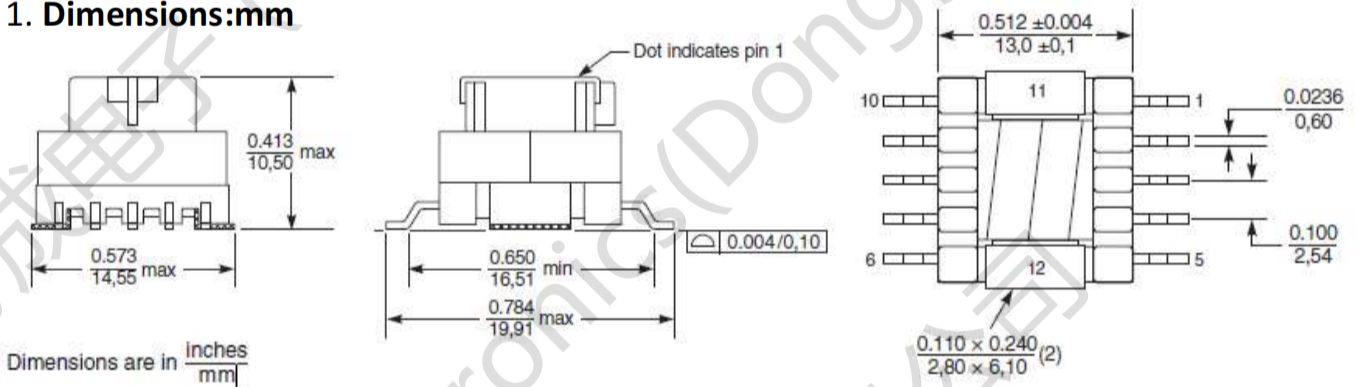

2.Schematic:

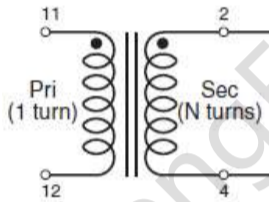

3. Typical Circuit

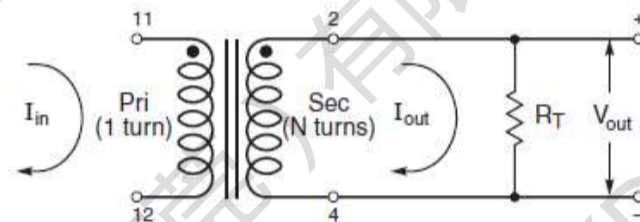

4. Recommended Land Pattern

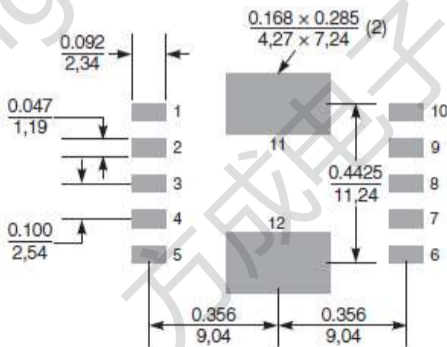

Temperature Rise vs Current

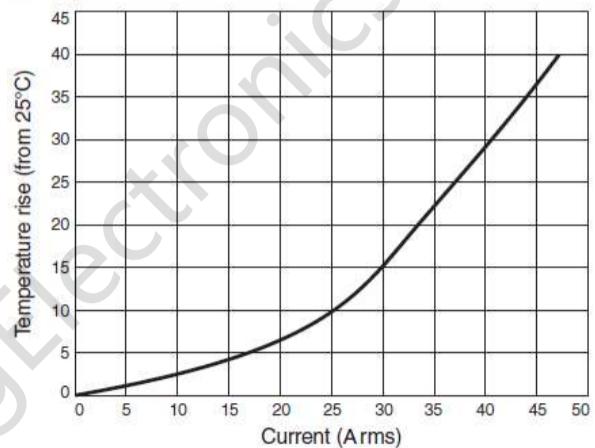

FC-SCT2010 -Series Current Sense Transformers

5. ELECTRIC CHARACTERICS)

Part Number	Turns Ration	Inductance (±30%.(mH)	HI-POT DC/NP-NS	DCR (mΩ /ΩMAX)		Sensed Current ⁵ I (A)
				Primary	Secondary	
FC-SCT2010-020T	1:20	0.34	1500V	0.36	0.180	47
FC-SCT2010-030T	1:30	0.76	1500V	0.36	0.265	47
FC-SCT2010-040T	1:40	1.36	1500V	0.36	0.560	47
FC-SCT2010-050T	1:50	2.12	1500V	0.36	0.705	47
FC-SCT2010-060T	1:60	3.06	1500V	0.36	0.850	47
FC-SCT2010-070T	1:70	4.16	1500V	0.36	1.00	47
FC-SCT2010-080T	1:80	5.44	1500V	0.36	1.15	47
FC-SCT2010-100T	1:100	8.50	1500V	0.36	1.45	47
FC-SCT2010-125T	1:125	13.3	1500V	0.36	1.85	47
FC-SCT2010-150T	1:150	19.2	1500V	0.36	2.25	47
FC-SCT2010-200T	1:200	34.0	1500V	0.36	4.06	47

Electrical Specifications @ 25°C — Operating Temperature -40°C to +125°C.

6. Notes:

1. The temperature of component (ambient temperature plus temperature rise) must be within the specified operating temperature range.
2. The maximum current rating is based upon temperature rise of the component and represents the DC current which will cause a typical temperature rise of 40°C with no airflow.
3. To calculate value of terminating resistor (Rt) use the following formula:
 $R_t (W) = V_{ref} * N / (I_{peak_primary})$
4. The peak flux density of the device must remain below 2000 Gauss. To calculate the peak flux density for uni-polar current use following formula:
 $B_{pk} = 37.59 * V_{ref} * (Duty_Cycle_Max) * 10^5 / (N * Freq_kHz)$ * for bi-polar current applications divide Bpk (as calculated above) by 2.

8. PACKAGE AND SEMBLABLE REQUIREMENT

