

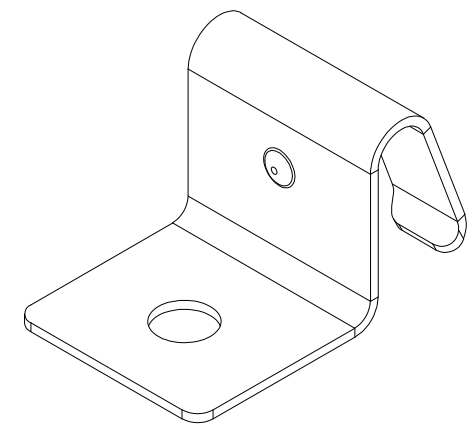

REV.	ECN NO.	REVISED	DATE

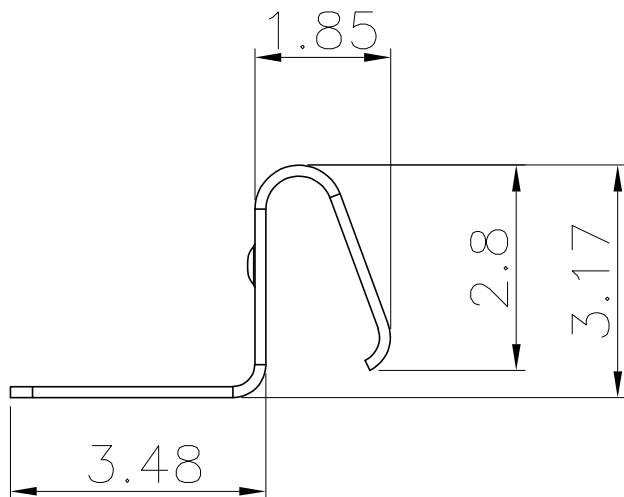
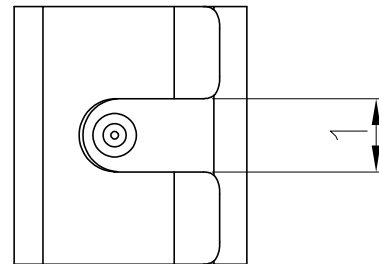
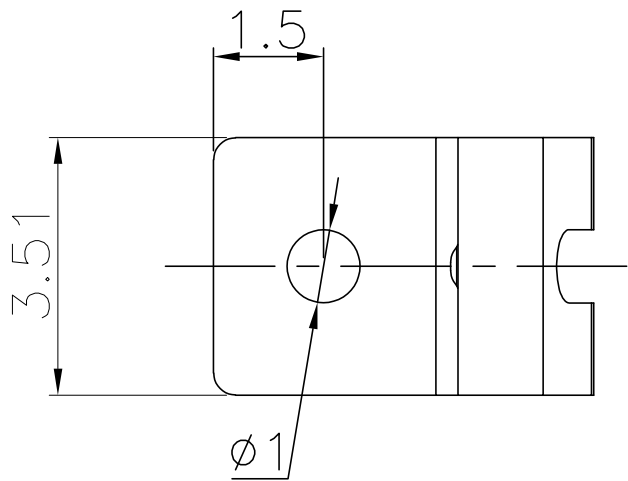

工程部
2023-11-15
H. WANG

UNLESS OTHERWISE SPECIFIED TOLERANCES		MYOUNG 美用 www.meiyangdz.com			
DECIMALS: X :±0.30 X.X :±0.25 X.XX :±0.20 X.XXX :±0.10	ANGLES: X :±1° X.X :±0.5°	DSND	WangHeng	DATE	2023-11-15
WEIGHT:		CHKD	ZhouRuicai	DATE	2023-11-15
SHEET 1 OF 2		APVD	XueShunyong	DATE	2023-11-15
		SCALE:	SIZE: A4	VIEW:	
		UNIT: mm	REV.: A/1	OBJECT: MY	DRAW NO.:MY-CP-0277
		TITLE:		PART NO.:	
		电池接触片-110 K 正极 镀铜 卷装		MY-ZJ-110PT-R	

1	TERMINAL(+)	1	QBeCu T=0.15mm	Au-Plating after heating
NO.	PART NAME	Q'TY	MATERIAL	PLATING & COLOR

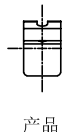

产品

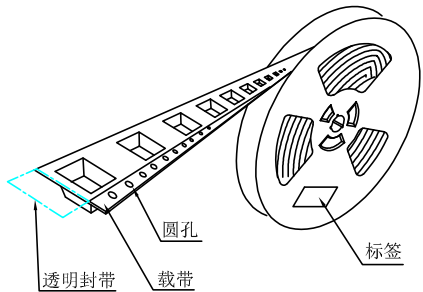

圆孔

透明封带

载带

标签

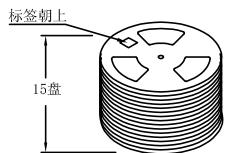

标签朝上

15盘

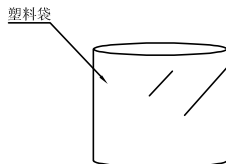

塑料袋

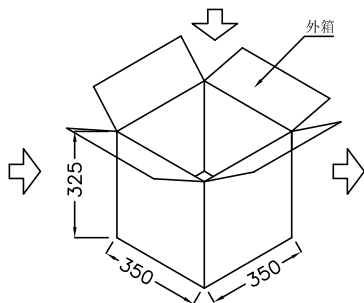

外箱

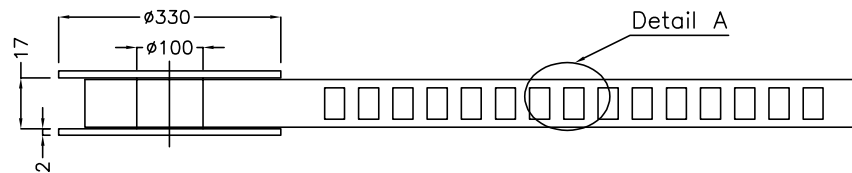
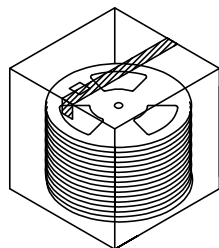

Detail A

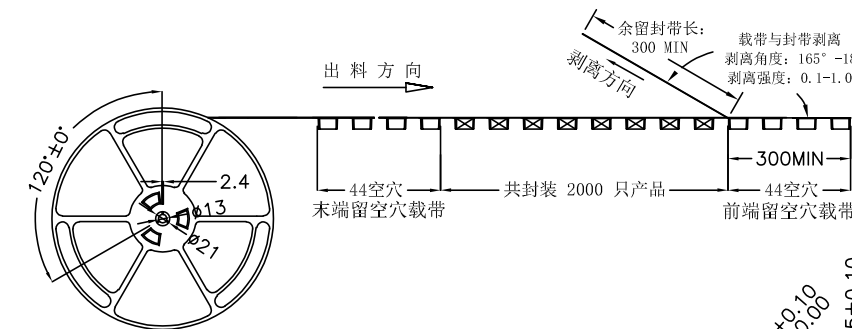

120°±0°

2.4

φ13

φ21

出料方向

剥离方向

余留封带长: 300 MIN

载带与封带剥离
剥离角度: 165°-180°
剥离强度: 0.1-1.0N

44空穴

共封装 2000 只产品

300MIN

末端留空穴载带

前端留空穴载带

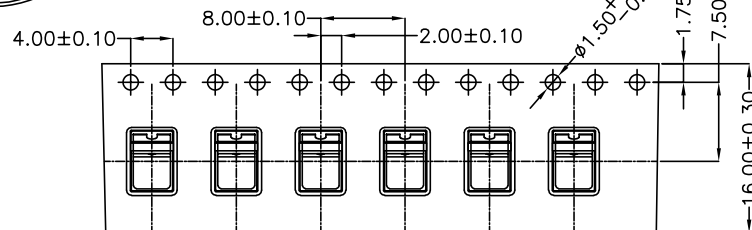

4.00±0.10

8.00±0.10

2.00±0.10

1.50±0.10

1.75±0.10

7.50±0.10

16.00±0.30

0.30±0.05

5.66±0.10

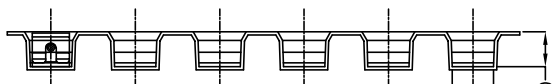

3.91±0.10

3.30±0.10

Detail A



工程部

2023-11-15

H. WANG

技术要求:

1. 圆孔十个孔距离累计允许公差为±0.2mm
2. 带长250mm内容许弯曲度1mm
3. 材料厚度以在载带边缘测量为准
4. 所有尺寸定义依循EIA-481-C系准则定义之
5. 材料: 黑色PS T=0.30±0.05mm
6. 所有卷轮为灰蓝挖空旋转塑胶卷轮
7. 整模成型长度: 16.704M,
8. 非指明公差范围为: ±0.1mm; 超过250mm不计算累计误差
9. 型腔外形凡未标明处倒角R为0.2-0.3; 拔模斜度未标注的为3° 以下

包装信息:

- 1、每卷盘装产品 2000 只, 卷盘外侧贴相关标签;
- 2、每 15 卷盘放在一个塑料袋中;
- 3、每外箱装15盘, 产品总数: 30000 只;
- 4、外箱上下用胶纸封成“工”字;
- 5、电池弹片包材-110 卷装 (MY-ZJ-110-01-R)。

UNLESS OTHERWISE SPECIFIED TOLERANCES		MYOUNG 美阳 www.meiyoungdz.com			
DECIMALS: X : ±*** X.X : ±*** X.XX : ±*** X.XXX : ±***	ANGLES: X : ±*** X.X : ±***	DSND WangHeng	DATE 2023-11-15	TITLE: 电池接触片-110 K 正极 镀铜 卷装	
WEIGHT:		CHKD ZhouRuicai	DATE 2023-11-15	PART NO.:	
SHEET 2 OF 2		APVD XueShun Yong	DATE 2023-11-15	MY-ZJ-110PT-R	
		SCALE: 1:1	SIZE: A4	VIEW:	DRAW NO.: MY-BD-0019
		UNIT: mm	REV.: A/0	OBJECT: MY	