

General Description

The XBLW TDA2030A is a monolithic integrated circuit in Pentawatt package, intended for use as an audio class AB audio amplifier. Thanks to its high power capability the TDA2030A is able to provide up to 35W true rms power into 4 ohm load @ THD = 10%, VS = 36V, f = 1KHz and up to 32W into 8ohm load @ THD = 10%, VS = 44V, f = 1KHz. Moreover, the TDA2030A delivers typically 50W music power into 4 ohm load over 1 sec at VS=22.5V, f = 1KHz. The high power and very low harmonic and crossover distortion (THD = 0.05% typ, @ VS = 44V, PO = 0.1 to 15W, RL=8ohm, f = 100Hz to 15KHz) make the device most suitable for both HiFi and high class TV sets.)

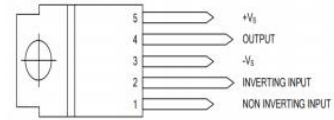
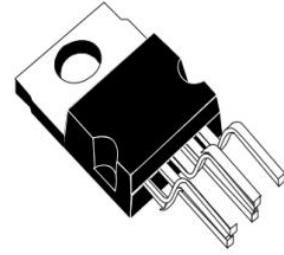

Ordering Information

Product Model	Package Type	Marking	Packing	Packing Qty
XBLW TDA2030A	T0-220B	TDA2030A	Tube	1000PCS/Box

TYPICAL APPLICATIONS

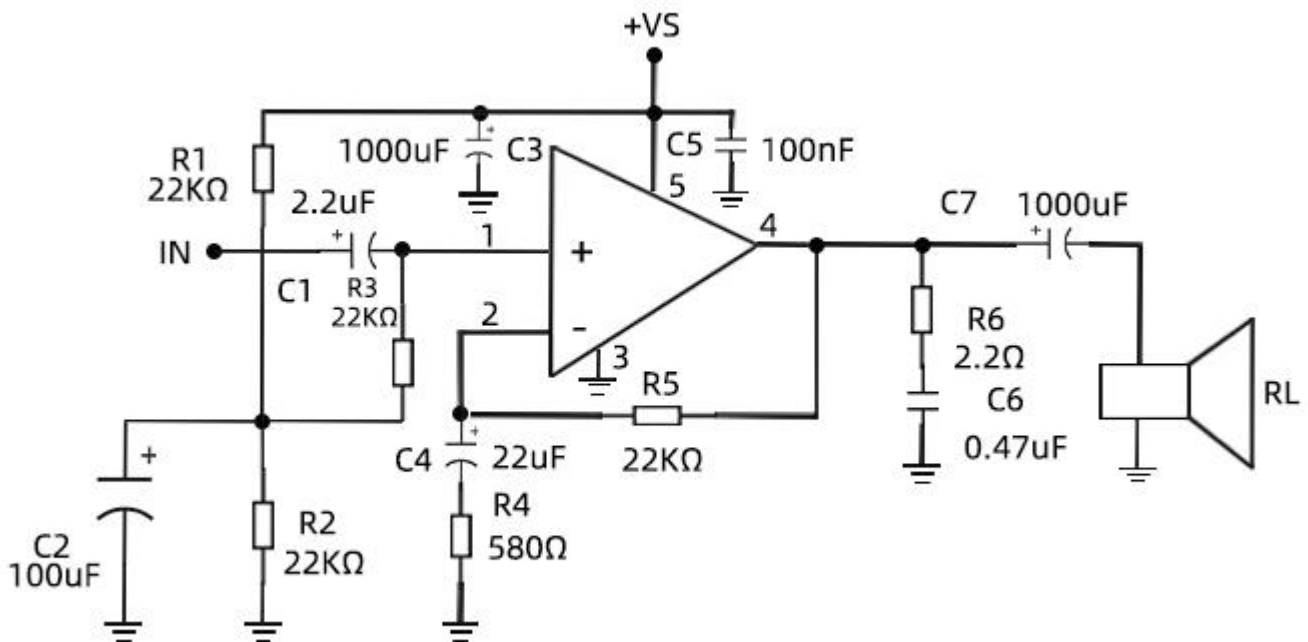

ABSOLUTE MAXIMUM RATINGS

Symbol	Parameter	Value	Unit
Vs	Supply Voltage	± 25	V
Vi	Input Voltage	Vs	
Vi	Differential Input Voltage	± 15	V
Io	Peak Output Current (internally limited)	4.5	A
Ptot	Total Power Dissipation at T case = 90 °C	25	W
Tstg, Tj	Storage and Junction Temperature	- 40 to + 150	°C

THERMAL DATA

Symbol	Parameter	Value	Unit
Rth (j-case)	Thermal Resistance Junction - case Max	3	°C/W

ELECTRICAL CHARACTERISTICS

(Refer to the test circuit, VS = ± 18V, Tamb = 25°C unless otherwise specified)

Symbol	Parameter	Test Conditions	Min.	Typ	Max.	Unit	
Vs	Supply Voltage		± 4.5	.	± 25	V	
Id	Quiescent Drain Current			26	35	mA	
Ib	Input Bias Current	VS = ± 22V		0.2	2	µA	
Vos	Input Offset Voltage	VS = ± 22V		± 2	± 20	mV	
Ios	Input Offset Current			± 20	± 200	nA	
PO	Output Power	d = 0.5%, Gv = 26dB f = 40 to 15KHz RL = 4Ω	24	28		W	
		RL = 8Ω		18		W	
		VS = ± 22V RL = 8Ω	22	25		W	
BW	Power Bandwidth	Po = 15W RL = 4Ω		40		kHz	
SR	Slew Rate			6		V/µsec	
Gv	Open Loop Voltage Gain	f = 1 kHz		80		dB	
Gv	Closed Loop Voltage Gain	f = 1 kHz	30	30.5	31	dB	
d	Total Harmonic Distortion	Po = 0.1 to 14W RL = 4Ω		0.08		%	
		f = 40 to 15KHz f = 1 kHz		0.03		%	
		Po = 0.1 to 9W					
		f = 40 to 15000Hz RL = 8Ω		0.5		%	
d2	Second Order CCIF Intermodulation Distortion			0.03		%	
d3	Third Order CCIF Intermodulation Distortion			0.08		%	
eN	Input Noise Voltage	B = Curve A		2		µV	
		B = 22Hz to 22kHz		3	10	µV	
iN	Input Noise Current	B = Curve A		50		pA	
		B = 22Hz to 22kHz		80	200	pA	
S/N	Signal to Noise Ratio	RL = 4Ω, Rg = 10kΩ, B = Curve A					
		PO = 15W		106		dB	
		PO = 1W		94		dB	
Ri	Input Resistance (pin 1)	(open loop) f = 1 kHz	0.5	5		MΩ	
SVR	Supply Voltage Rejection	RL = 4Ω, Rg = 22kΩ Gv = 26dB, f = 100 Hz		45		dB	
Tj	Thermal Shut-down Junction			140		°C	

Figure 1 : Single Supply Amplifier

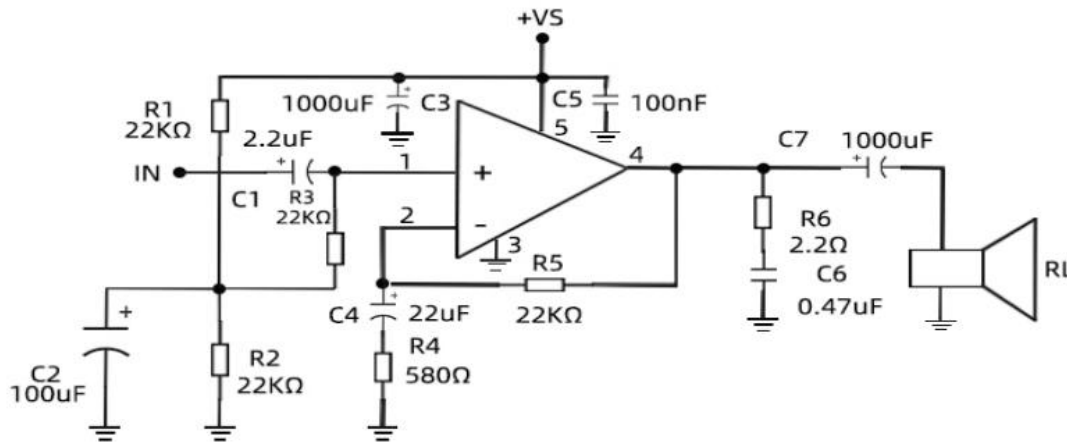

Figure 2 : Open Loop-frequency Response

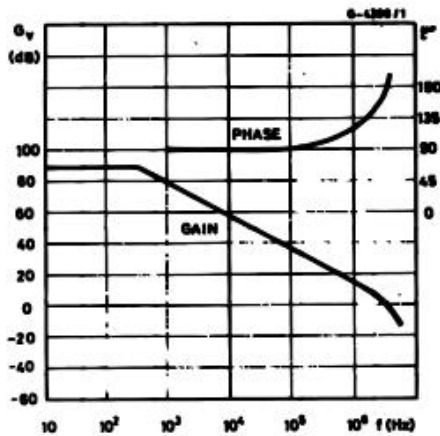

Figure 4 : Total Harmonic Distortion versus Output Power (test using rise filters)

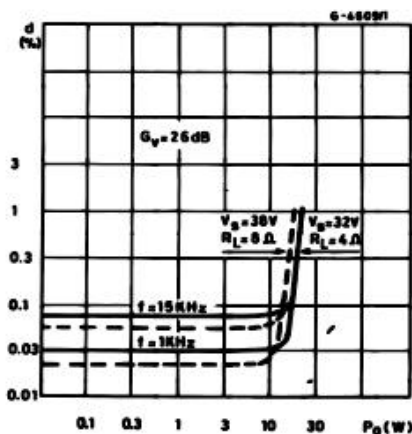

Figure 3 : Output Power versus Supply Voltage

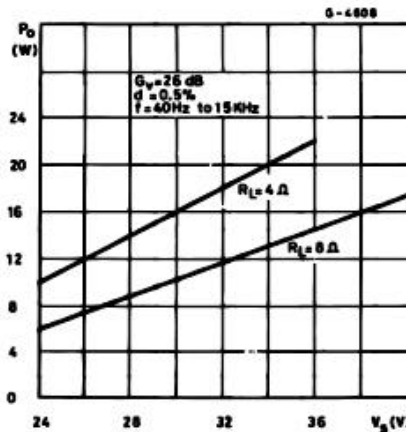

Figure 5 : Two Tone CCIF Intremodulation Distortion

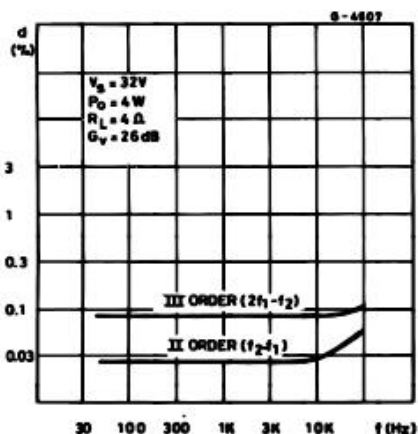

Figure 6 : Large Signal Frequency Response

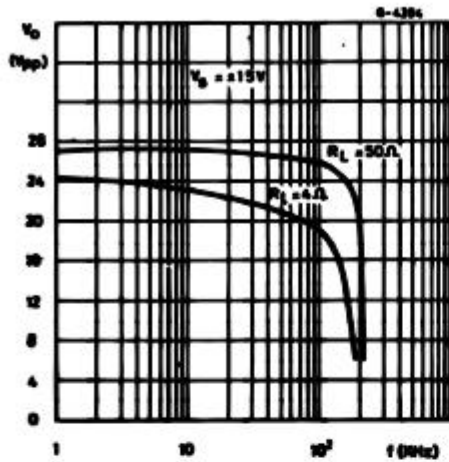

Figure 7 : Maximum Allowable Power Dissipation versus Ambient Temperature

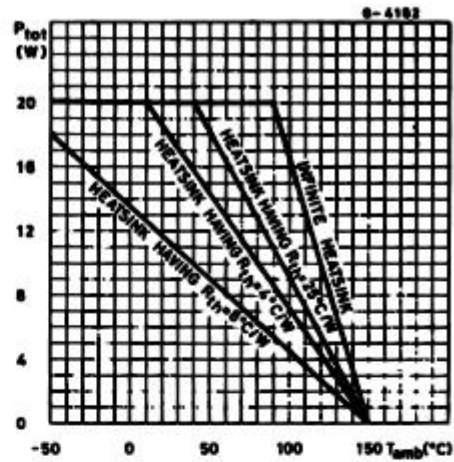

Figure 8 : Output Power versus Supply Voltage

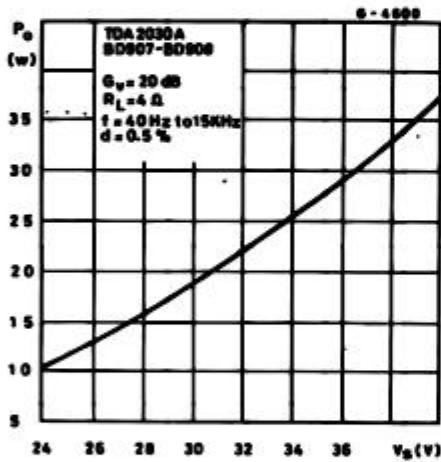

Figure 9 : Total Harmonic Distortion versus Output Power

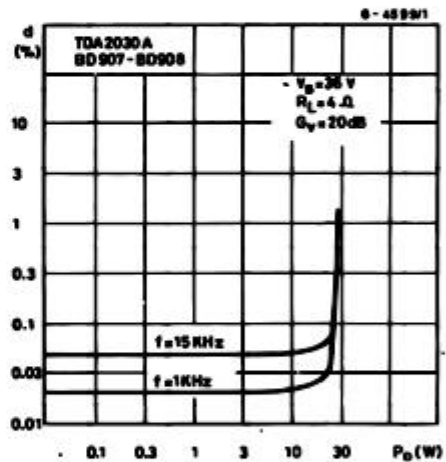

Figure 10 : Output Power versus Input Level

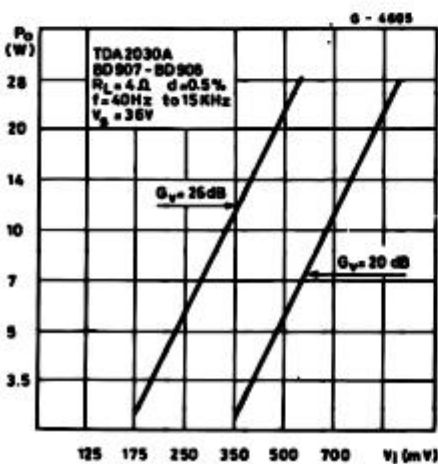

Figure 11 : Power Dissipation versus Output Power

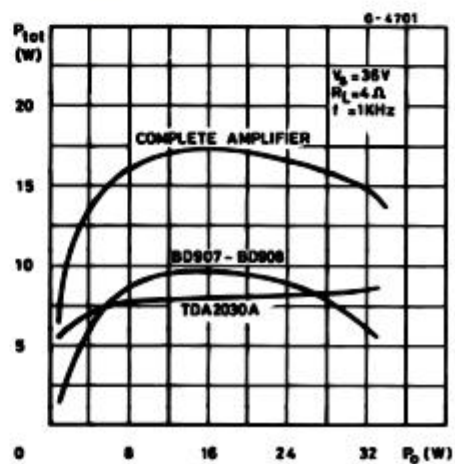

Figure 12 : Typical Amplifier with Split Power Supply

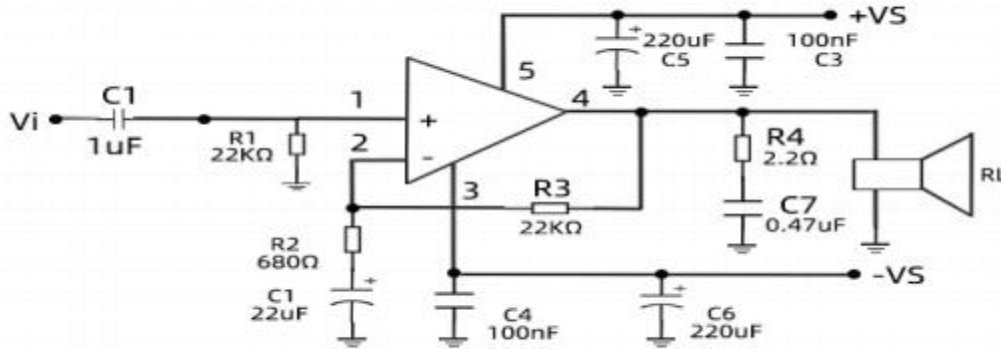
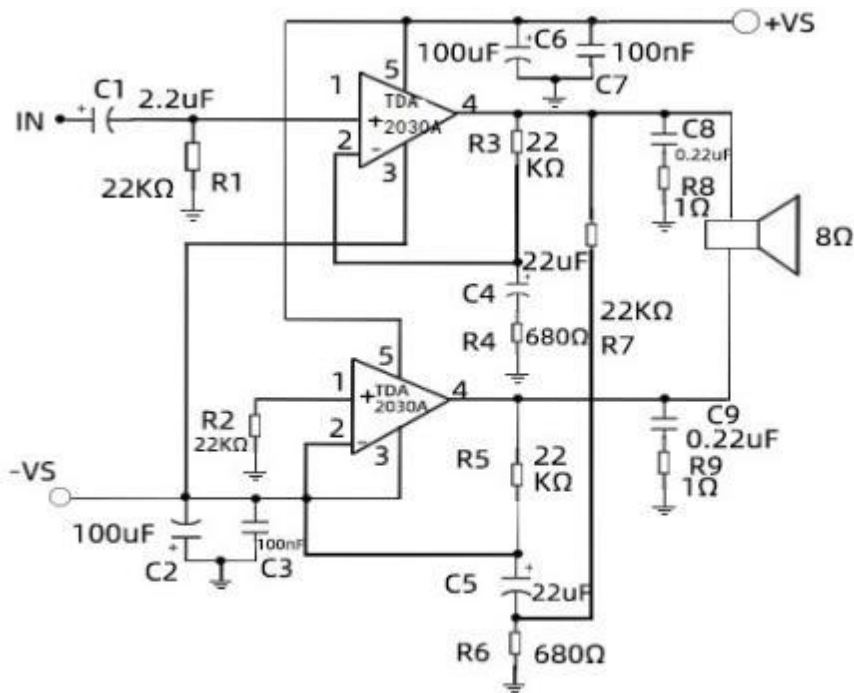

Figure 13 : Bridge Amplifier with Split Power Supply (PO = 34W , VS = ± 16V)



Outline Drawing

TO-220B
: mm

Unit

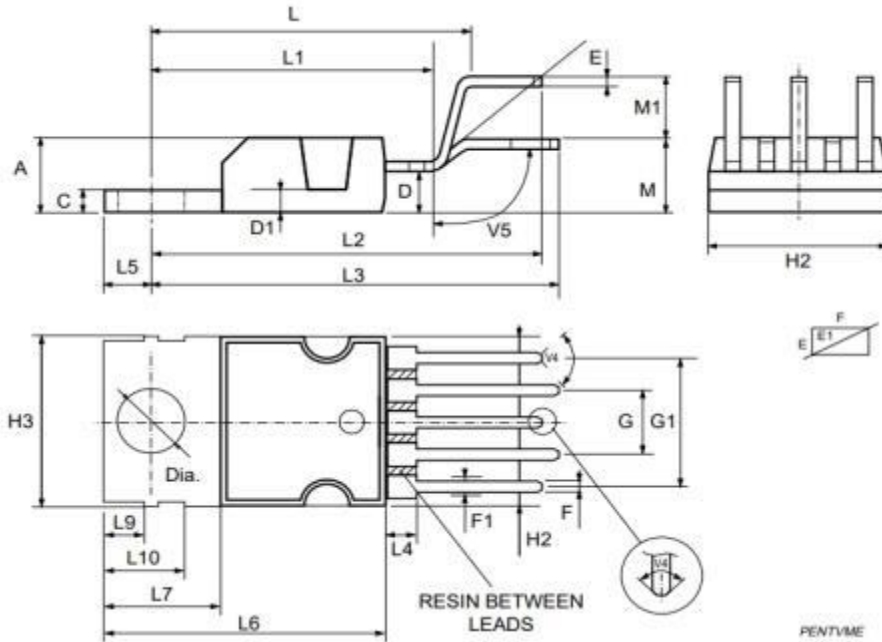

DIM.	mm			Inch		
	MIN.	TYP.	MAX.	MIN.	TYP.	MAX.
A			4.8			0.189
C			1.37			0.054
D	2.4		2.8	0.094		0.110
D1	1.2		1.35	0.047		0.053
E	0.35		0.55	0.014		0.022
E1	0.76		1.19	0.030		0.047
F	0.8		1.05	0.031		0.041
F1	1.0		1.4	0.039		0.055
G	3.2	3.4	3.6	0.126	0.134	0.142
G1	6.6	6.8	7.0	0.260	0.268	0.276
H2			10.4			0.409
H3	10.05		10.4	0.396		0.409
L	17.55	17.85	18.15	0.691	0.703	0.715
L1	15.55	15.75	15.95	0.612	0.620	0.628
L2	21.2	21.4	21.6	0.831	0.843	0.850
L3	22.3	22.5	22.7	0.878	0.886	0.894
L4			1.29			0.051
L5	2.6		3.0	0.102		0.118
L6	15.1		15.8	0.594		0.622
L7	6.0		6.6	0.236		0.260
L9	2.1		2.7	0.008		0.106
L10	4.3		4.8	0.17		0.189
M	4.23	4.5	4.75	0.167	0.178	0.187
M1	3.75	4.0	4.25	0.148	0.157	0.167
V4			40° (typ.)			
V5			90° (typ.)			
Dia	3.65		3.85	0.144		0.152

Statement:

- ◇ Shenzhen xinbole electronics co., ltd. reserves the right to change the product specifications, without notice! Before placing an order, the customer needs to confirm whether the information obtained is the latest version, and verify the integrity of the relevant information.
- ◇ Any semiconductor product is liable to fail or malfunction under certain conditions, and the buyer shall be responsible for complying with safety standards in the system design and whole machine manufacturing using Shenzhen xinbole electronics co., ltd products, and take appropriate security measures to avoid the potential risk of failure may result in personal injury or property losses of the situation occurred!
- ◇ Product performance is never ending, Shenzhen xinbole electronics co., ltd will be dedicated to provide customers with better performance, better quality of integrated circuit products.