

N-Channel Enhancement Mode Field Effect Transistor

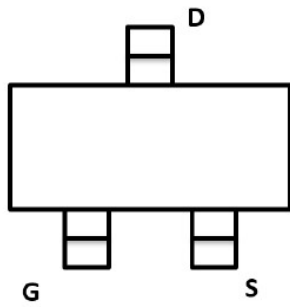

SOT-23

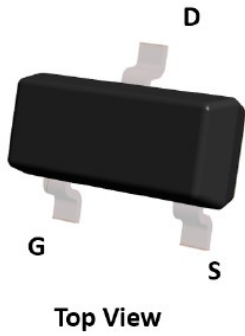
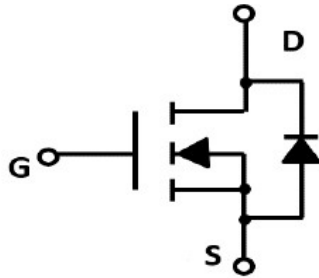

Product Summary

- V_{DS} 20V
- I_D 6.8A
- $R_{DS(ON)}$ (at $V_{GS}=4.5V$) < 18mohm
- $R_{DS(ON)}$ (at $V_{GS}=2.5V$) < 22mohm
- $R_{DS(ON)}$ (at $V_{GS}=1.8V$) < 39mohm
- 100% ∇V_{DS} Tested

General Description

- Trench Power LV MOSFET technology
- High Power and current handling capability

Applications

- PWM applications
- Load switch

■ Absolute Maximum Ratings ($T_A=25^\circ\text{C}$ unless otherwise noted)

Parameter	Symbol	Limit	Unit
Drain-source Voltage	V_{DS}	20	V
Gate-source Voltage	V_{GS}	± 10	V
Drain Current	I_D	$T_A=25^\circ\text{C}$	6.8
		$T_A=70^\circ\text{C}$	5.4
Pulsed Drain Current ^A	I_{DM}	27	A
Total Power Dissipation	P_D	$T_A=25^\circ\text{C}$	1.25
		$T_A=70^\circ\text{C}$	0.8
Thermal Resistance Junction-to-Ambient ^B	$R_{\theta JA}$	100	$^\circ\text{C}/\text{W}$
Junction and Storage Temperature Range	T_J, T_{STG}	-55~+150	$^\circ\text{C}$

■ Ordering Information (Example)

PREFERRED P/N	PACKING CODE	Marking	MINIMUM PACKAGE(pcs)	INNER BOX QUANTITY(pcs)	OUTER CARTON QUANTITY(pcs)	DELIVERY MODE
ZXL2312A	F2	S12.	3000	30000	120000	7" reel

ZXL2312A

■ Electrical Characteristics (T_J=25°C unless otherwise noted)

Parameter	Symbol	Conditions	Min	Typ	Max	Units
Static Parameter						
Drain-Source Breakdown Voltage	BV _{DSS}	V _{GS} =0V, I _D =250μA	20			V
Zero Gate Voltage Drain Current	I _{DSS}	V _{DS} =20V, V _{GS} =0V			1	μA
Gate-Body Leakage Current	I _{GSS}	V _{GS} =±10V, V _{DS} =0V			±100	nA
Gate Threshold Voltage	V _{GS(th)}	V _{DS} =V _{GS} , I _D =250μA	0.45	0.62	1.0	V
Static Drain-Source On-Resistance	R _{DS(on)}	V _{GS} =4.5V, I _D =6.8A		13.5	18	mΩ
		V _{GS} =2.5V, I _D =3A		17	22	
		V _{GS} =1.8V, I _D =2.5A		22	39	
Diode Forward Voltage	V _{SD}	I _S =6.8A, V _{GS} =0V			1.2	V
Dynamic Parameters						
Input Capacitance	C _{iss}	V _{DS} =10V, V _{GS} =0V, f=1MHZ		888		pF
Output Capacitance	C _{oss}			133		
Reverse Transfer Capacitance	C _{rss}			117		
Switching Parameters						
Total Gate Charge	Q _g	V _{GS} =4.5V, V _{DS} =10V, I _D =6.8A		11.05		nC
Gate-Source Charge	Q _{gs}			1.73		
Gate-Drain Charge	Q _{gd}			3.1		
Turn-on Delay Time	t _{D(on)}	V _{GS} =4.5V, V _{DS} =10V, I _D =6.8A R _{GEN} =3Ω		7		ns
Turn-on Rise Time	t _r			46		
Turn-off Delay Time	t _{D(off)}			30		
Turn-off fall Time	t _f			52		

A. Pulse Test: Pulse Width ≤ 300us, Duty cycle ≤ 2%.

B. R_{θJA} is the sum of the junction-to-case and case-to-ambient thermal resistance, where the case thermal reference is defined as the solder mounting surface of the drain pins. R_{θJC} is guaranteed by design, while R_{θJA} is determined by the board design. The maximum rating presented here is based on mounting on a 1 in 2 pad of 2oz copper.

■ Typical Performance Characteristics

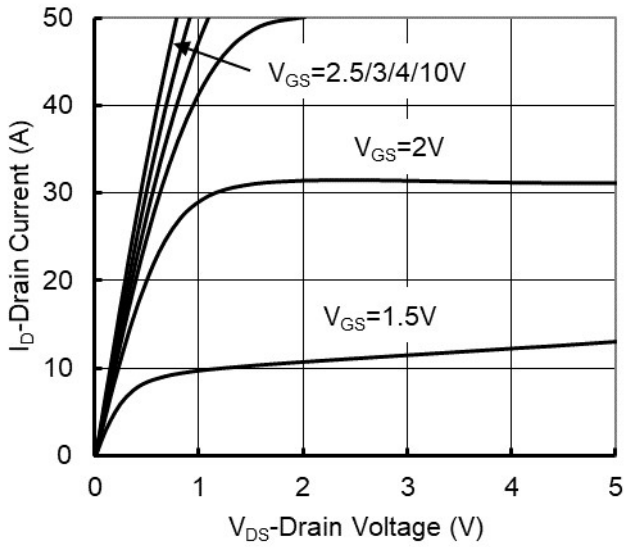

Figure1. Output Characteristics

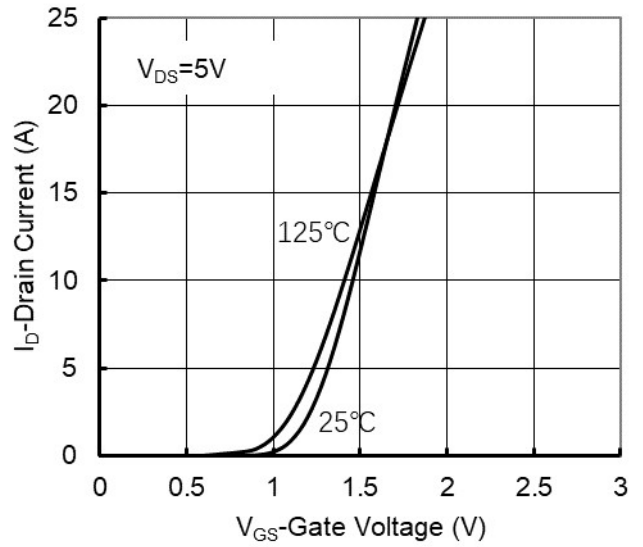

Figure2. Transfer Characteristics

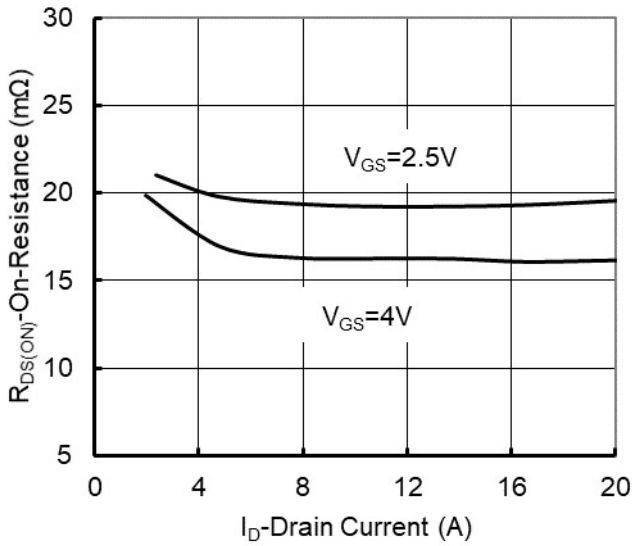

Figure 3: On-Resistance vs. Drain Current and Gate Voltage

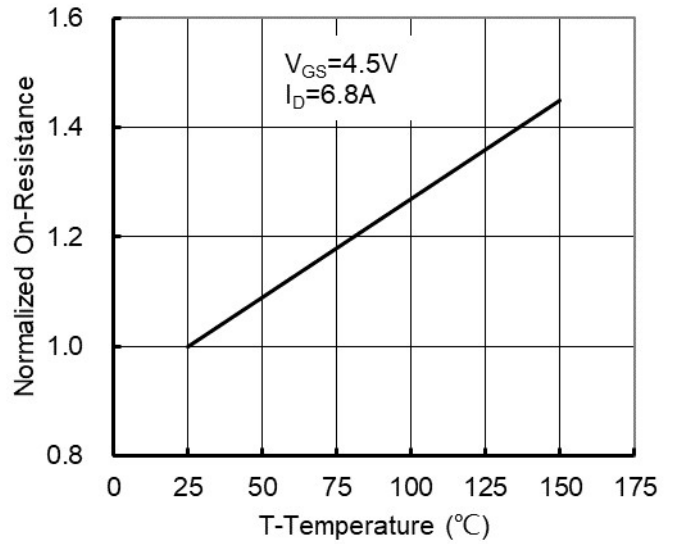

Figure 4: On-Resistance vs. Junction Temperature

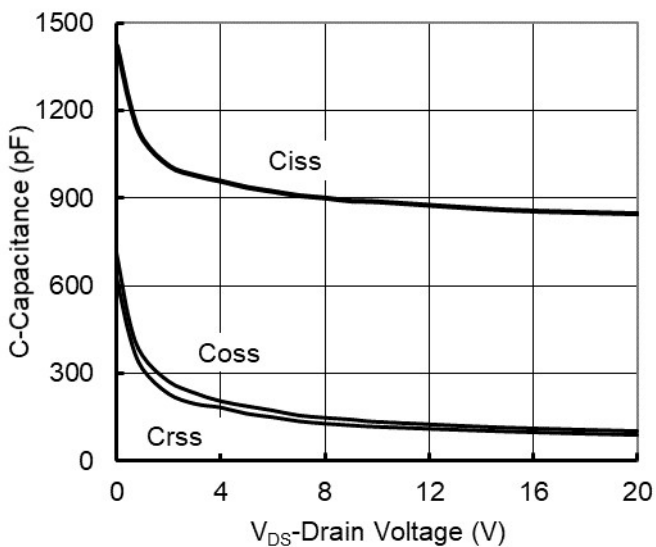

Figure5. Capacitance Characteristics

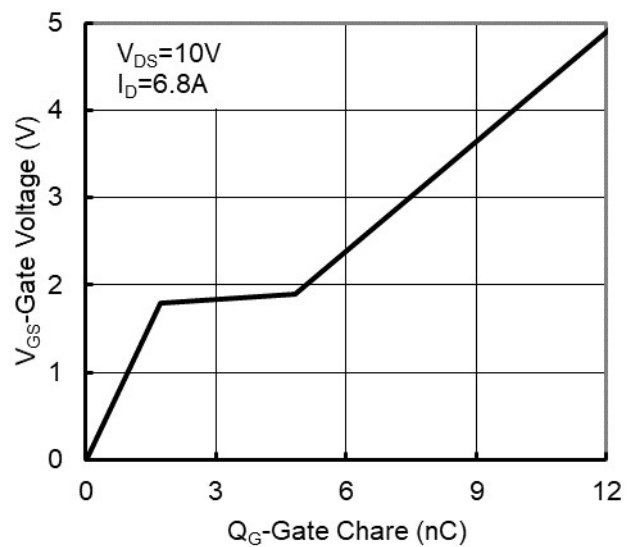

Figure6. Gate Charge

ZXL2312A

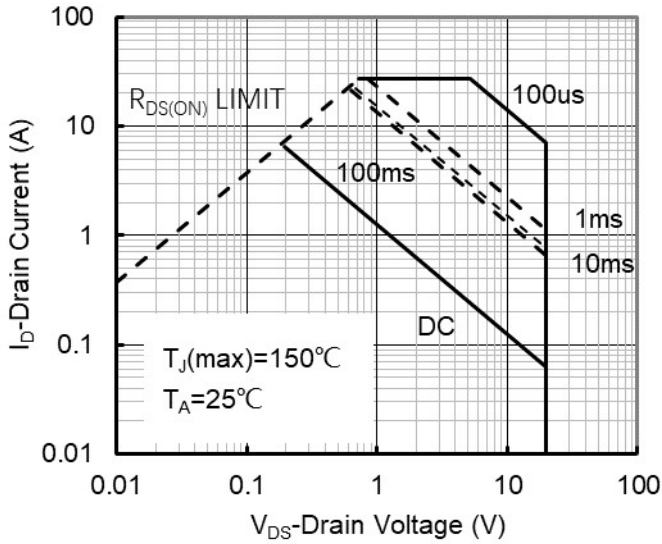

Figure7. Safe Operation Area

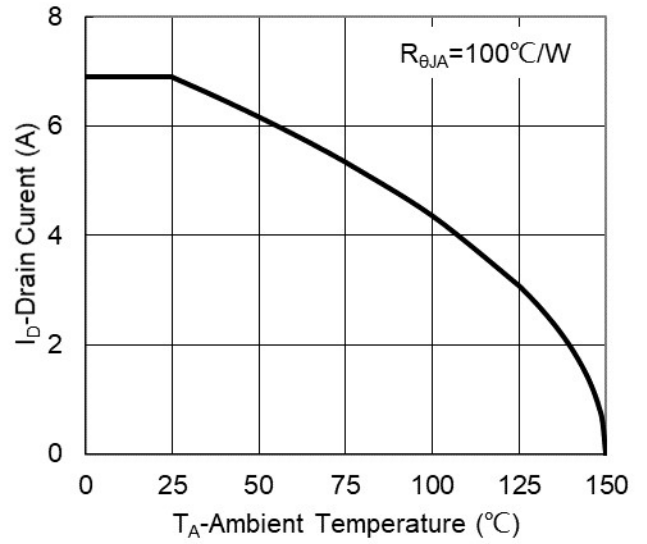

Figure8. Maximum Continuous Drain Current vs Ambient Temperature

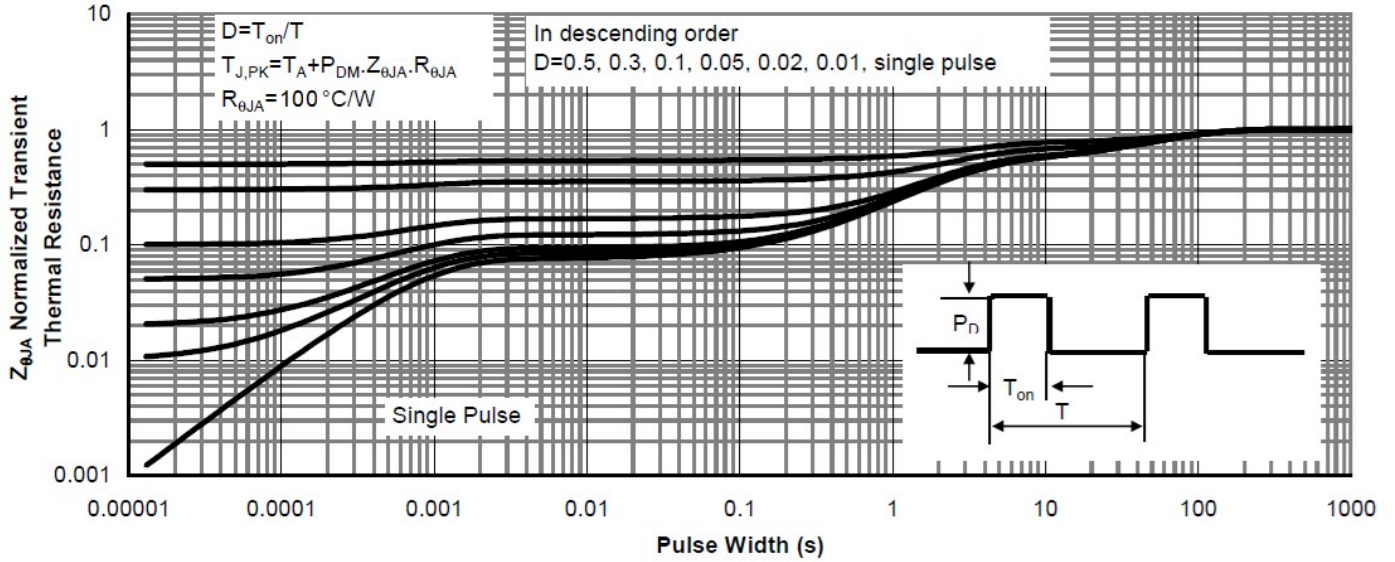
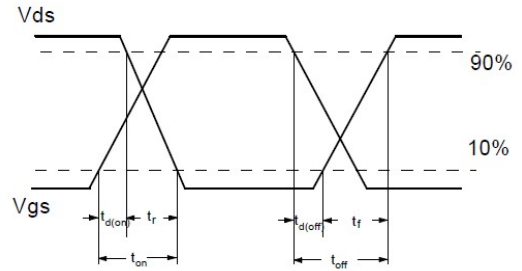
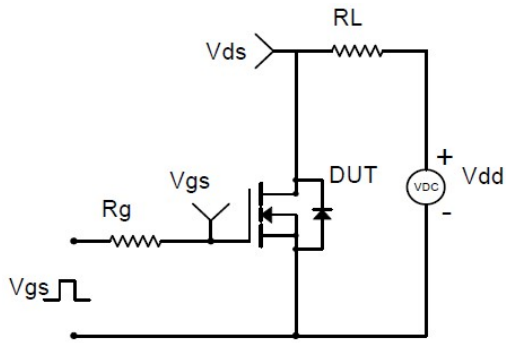
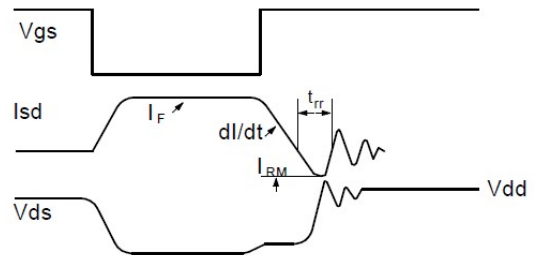
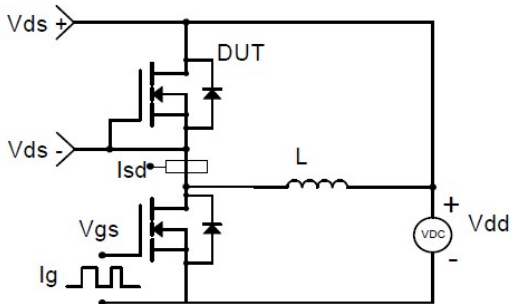

Figure9. Normalized Maximum Transient Thermal Impedance

ZXL2312A



Resistive Switching Test Circuit & Waveforms



Diode Recovery Test Circuit & Waveforms

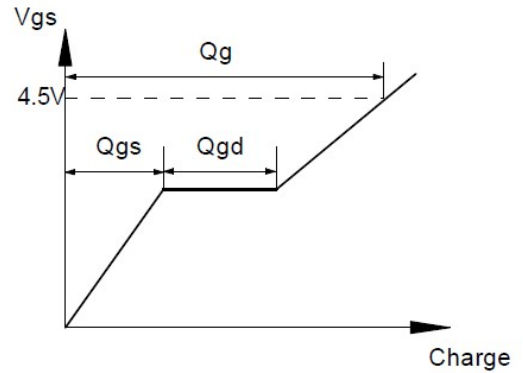
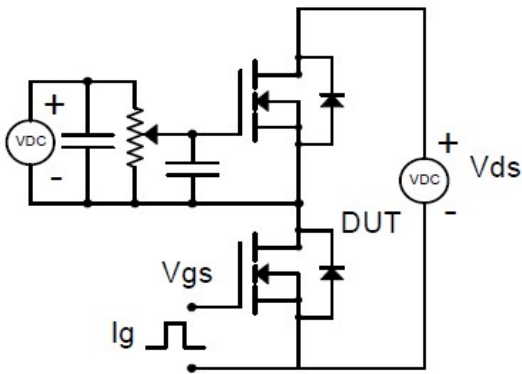

Gate Charge Test Circuit & Waveform

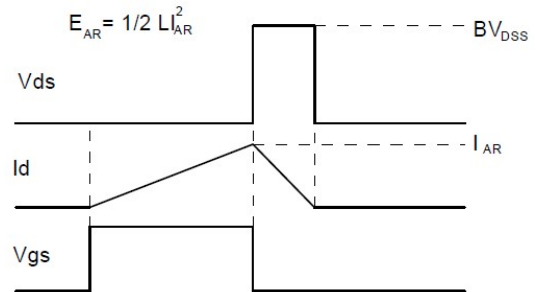
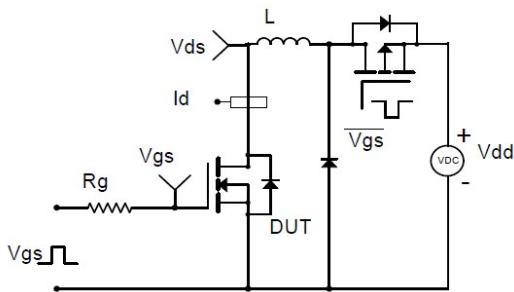

Unclamped Inductive Switching (UIS) Test Circuit & Waveforms

ZXL2312A

■ SOT-23 Package information

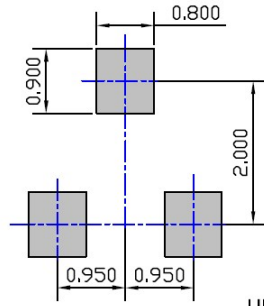
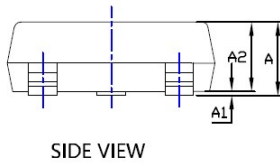
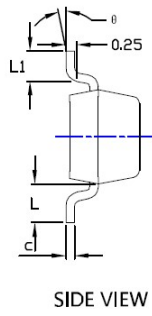
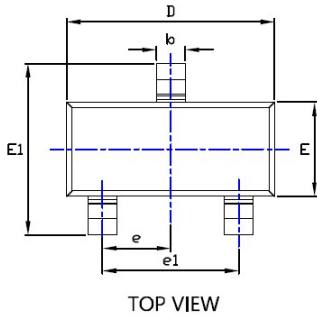

UNIT: mm

SYMBOL	DIMENSIONS					
	INCHES			Millimeter		
	MIN.	NOM.	MAX.	MIN.	NOM.	MAX.
A	0.035	---	0.045	0.900	---	1.150
A1	0.000	---	0.004	0.000	---	0.100
A2	0.035	0.038	0.041	0.900	0.975	1.050
b	0.012	0.016	0.020	0.300	0.400	0.500
c	0.004	---	0.008	0.100	---	0.200
D	0.110	0.114	0.118	2.800	2.900	3.000
E	0.047	0.051	0.055	1.200	1.300	1.400
E1	0.089	0.094	0.100	2.250	2.400	2.550
e	0.037 TYP			0.950 TYP		
e1	0.071	0.075	0.079	1.800	1.900	2.000
L	0.022 REF			0.550 REF		
L1	0.012	0.016	0.200	0.300	0.400	0.500
θ	0°	---	8°	0°	---	8°

NOTE:

1. PACKAGE BODY SIZES EXCLUDE MOLD FLASH AND GATE BURRS.
2. TOLERANCE 0.1mm UNLESS OTHERWISE SPECIFIED.
3. THE PAD LAYOUT IS FOR REFERENCE PURPOSES ONLY.