

## P-Channel Enhancement Mode Field Effect Transistor

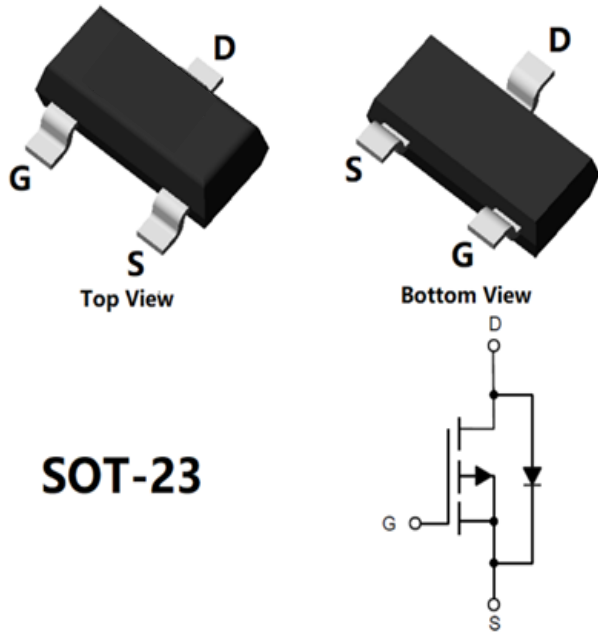

**SOT-23**

### Product Summary

- $V_{DS}$  -30V
- $I_D$  -4.4A
- $R_{DS(ON)}$ ( at  $V_{GS}=-10V$ ) <55mohm
- $R_{DS(ON)}$ ( at  $V_{GS}=-4.5V$ ) <66mohm
- $R_{DS(ON)}$ ( at  $V_{GS}=-2.5V$ ) <94mohm

### General Description

- Trench Power LV MOSFET technology
- High density cell design for Low  $R_{DS(ON)}$
- High Speed switching
- Moisture Sensitivity Level 1
- Epoxy Meets UL 94 V-0 Flammability Rating
- Halogen Free

### Applications

- Battery protection
- Power management
- Load switch

### ■ Absolute Maximum Ratings ( $T_A=25^\circ\text{C}$ unless otherwise noted)

Parameter		Symbol	Limit	Unit
Drain-source Voltage		$V_{DS}$	-30	V
Gate-source Voltage		$V_{GS}$	$\pm 12$	V
Drain Current	$T_A=25^\circ\text{C}$	$I_D$	-4.4	A
	$T_A=70^\circ\text{C}$		-3.5	
Pulsed Drain Current <sup>A</sup>		$I_{DM}/I_{SM}$	-27	A
Total Power Dissipation	$T_A=25^\circ\text{C}$	$P_D$	1.2	W
	$T_A=70^\circ\text{C}$		0.8	W
Thermal Resistance Junction-to-Ambient <sup>B</sup>		$R_{\theta JA}$	104	$^\circ\text{C}/\text{W}$
Junction and Storage Temperature Range		$T_J, T_{STG}$	-55~+150	$^\circ\text{C}$

### ■ Ordering Information (Example)

PREFERRED P/N	PACKING CODE	Marking	MINIMUM PACKAGE(pcs)	INNER BOX QUANTITY(pcs)	OUTER CARTON QUANTITY(pcs)	DELIVERY MODE
ZXL3401A	F2	3401.	3000	30000	120000	7" reel

# ZXL3401A

## ■ Electrical Characteristics (T<sub>J</sub>=25°C unless otherwise noted)

Parameter	Symbol	Conditions	Min	Typ	Max	Units
<b>Static Parameter</b>						
Drain-Source Breakdown Voltage	BV <sub>DSS</sub>	V <sub>GS</sub> =0V, I <sub>D</sub> =-250μA	-30			V
Zero Gate Voltage Drain Current	I <sub>DSS</sub>	V <sub>DS</sub> =-30V, V <sub>GS</sub> =0V			-1	μA
Gate-Body Leakage Current	I <sub>GSS</sub>	V <sub>GS</sub> =±12V, V <sub>DS</sub> =0V			±100	nA
Gate Threshold Voltage	V <sub>GS(th)</sub>	V <sub>DS</sub> =V <sub>GS</sub> , I <sub>D</sub> =-250μA	-0.6	-0.9	-1.4	V
Static Drain-Source On-Resistance	R <sub>DS(on)</sub>	V <sub>GS</sub> =-10V, I <sub>D</sub> =-4.4A		40	55	mΩ
		V <sub>GS</sub> =-4.5V, I <sub>D</sub> =-4A		47	66	
		V <sub>GS</sub> =-2.5V, I <sub>D</sub> =-2A		60	94	
Diode Forward Voltage	V <sub>SD</sub>	I <sub>S</sub> =-4.4A, V <sub>GS</sub> =0V			-1.2	V
Gate resistance	R <sub>G</sub>	f=1MHz, Open drain	-	15	-	Ω
Maximum Body-Diode Continuous Current	I <sub>S</sub>		-	-	-4.4	A
Forward Transconductance	g <sub>FS</sub>	V <sub>DS</sub> =-5V, I <sub>D</sub> =-15A	-	15	-	S
<b>Dynamic Parameters</b>						
Input Capacitance	C <sub>iss</sub>	V <sub>DS</sub> =-15V, V <sub>GS</sub> =0V, f=1MHZ		1040		pF
Output Capacitance	C <sub>oss</sub>			80		
Reverse Transfer Capacitance	C <sub>rss</sub>			68		
<b>Switching Parameters</b>						
Total Gate Charge	Q <sub>g</sub>	V <sub>GS</sub> =-10V, V <sub>DS</sub> =-15V, I <sub>D</sub> =-4.4A		22		nC
Gate-Source Charge	Q <sub>gs</sub>			3.28		
Gate-Drain Charge	Q <sub>gd</sub>			2.11		
Reverse Recovery Charge	Q <sub>rr</sub>	I <sub>F</sub> =-4.4A, di/dt=100A/us	-	10	-	nC
Reverse Recovery Time	t <sub>rr</sub>		-	16	-	ns
Turn-on Delay Time	t <sub>D(on)</sub>	V <sub>GS</sub> =-10V, V <sub>DS</sub> =-15V, I <sub>D</sub> =4.4A R <sub>GEN</sub> =3Ω		4.4		ns
Turn-on Rise Time	t <sub>r</sub>			26		
Turn-off Delay Time	t <sub>D(off)</sub>			49.2		
Turn-off fall Time	t <sub>f</sub>			42.8		

A. Pulse Test: Pulse Width ≤ 300us, Duty cycle ≤ 2%.

B. R<sub>θJA</sub> is the sum of the junction-to-case and case-to-ambient thermal resistance, where the case thermal reference is defined as the solder mounting surface of the drain pins. R<sub>θJC</sub> is guaranteed by design, while R<sub>θJA</sub> is determined by the board design. The maximum rating presented here is based on mounting on a 1 in 2 pad of 2oz copper.

## ■ Typical Performance Characteristics

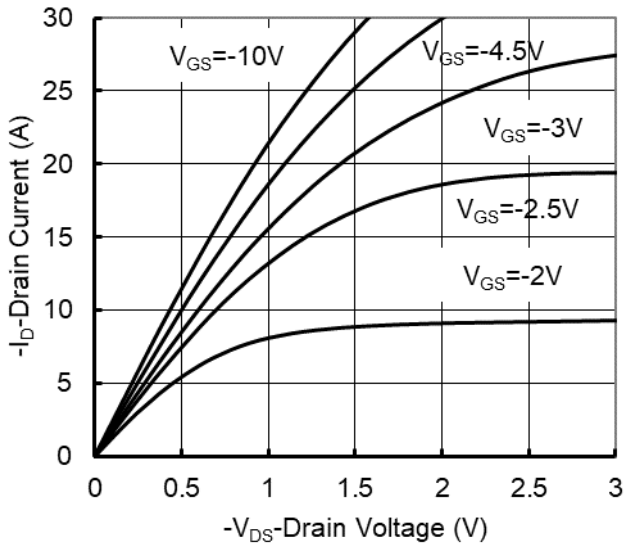

Figure1. Output Characteristics

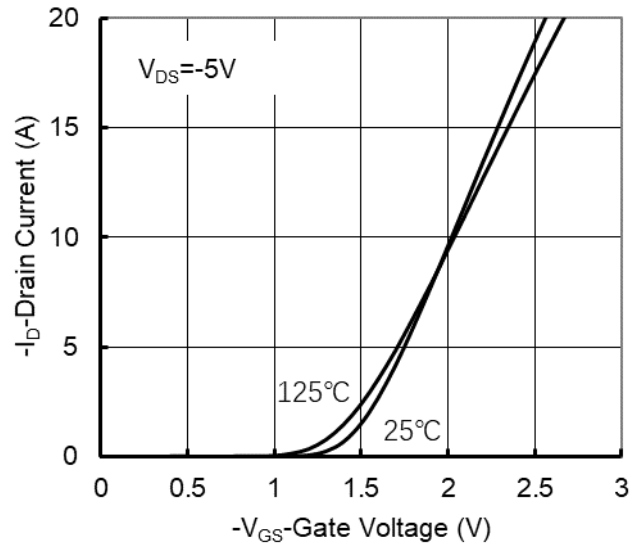

Figure2. Transfer Characteristics

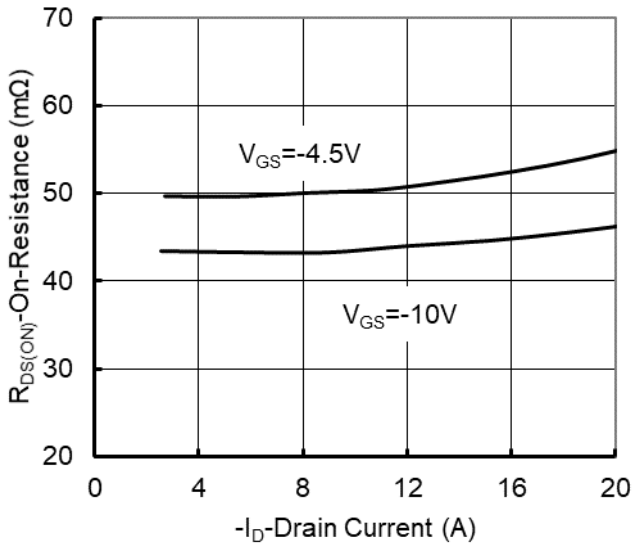

Figure 3: On-Resistance vs. Drain Current and Gate Voltage

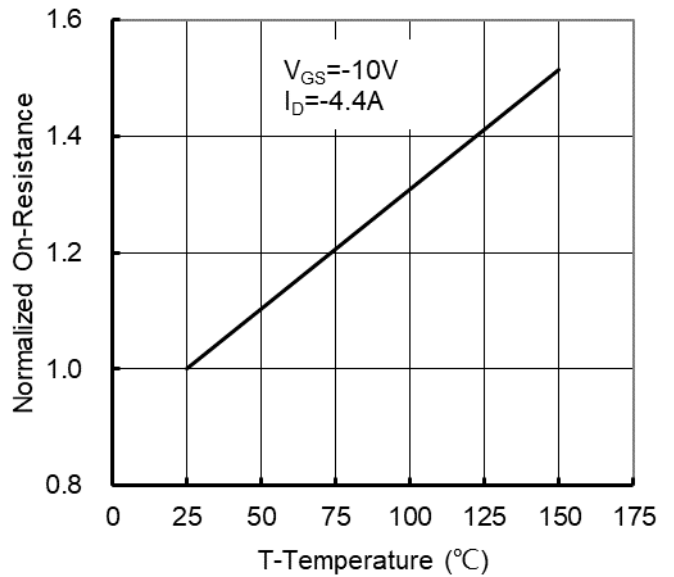

Figure 4: On-Resistance vs. Junction Temperature

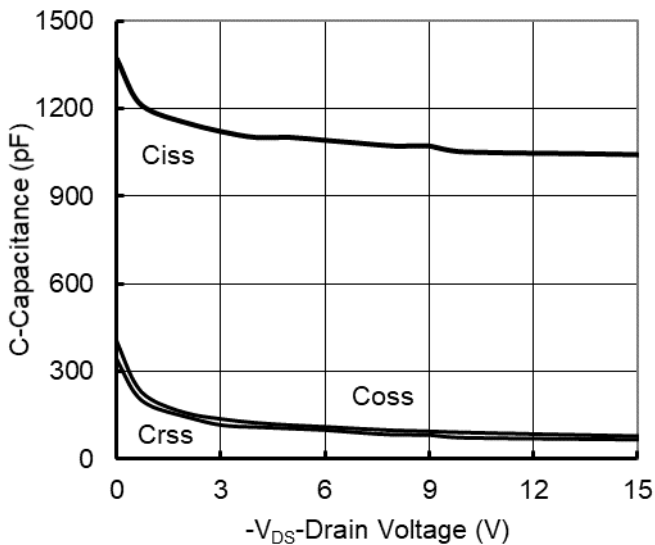

Figure5. Capacitance Characteristics

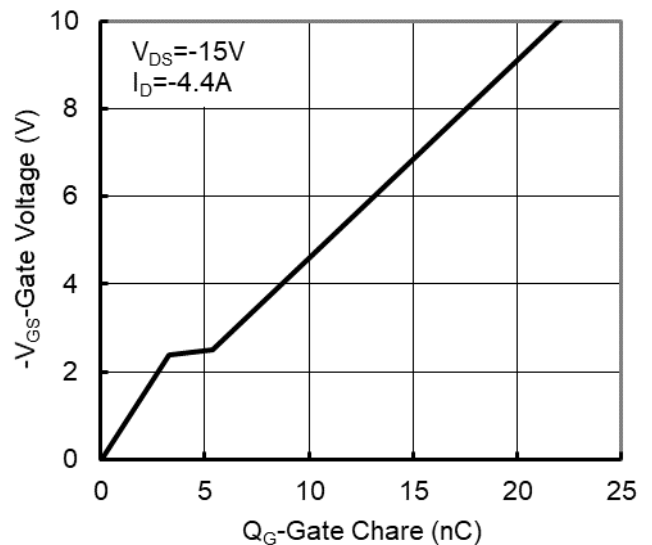

Figure6. Gate Charge

# ZXL3401A

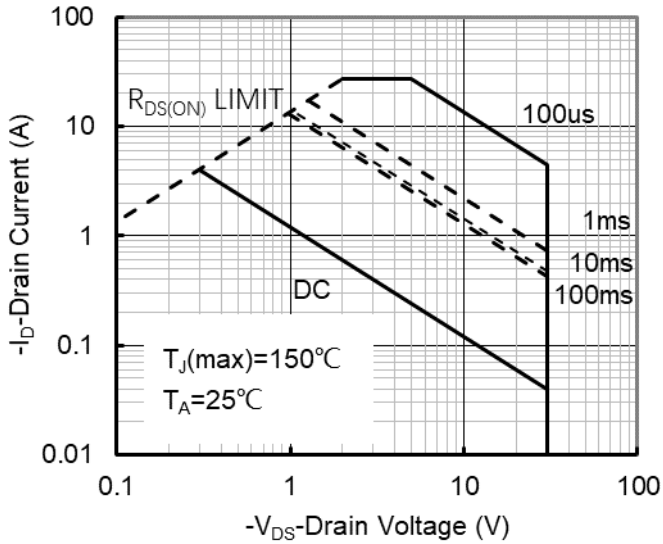

Figure7. Safe Operation Area

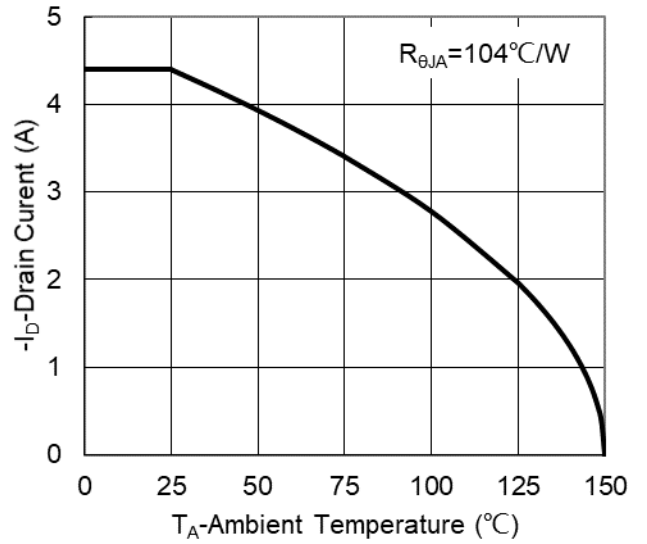

Figure8. Maximum Continuous Drain Current vs Ambient Temperature

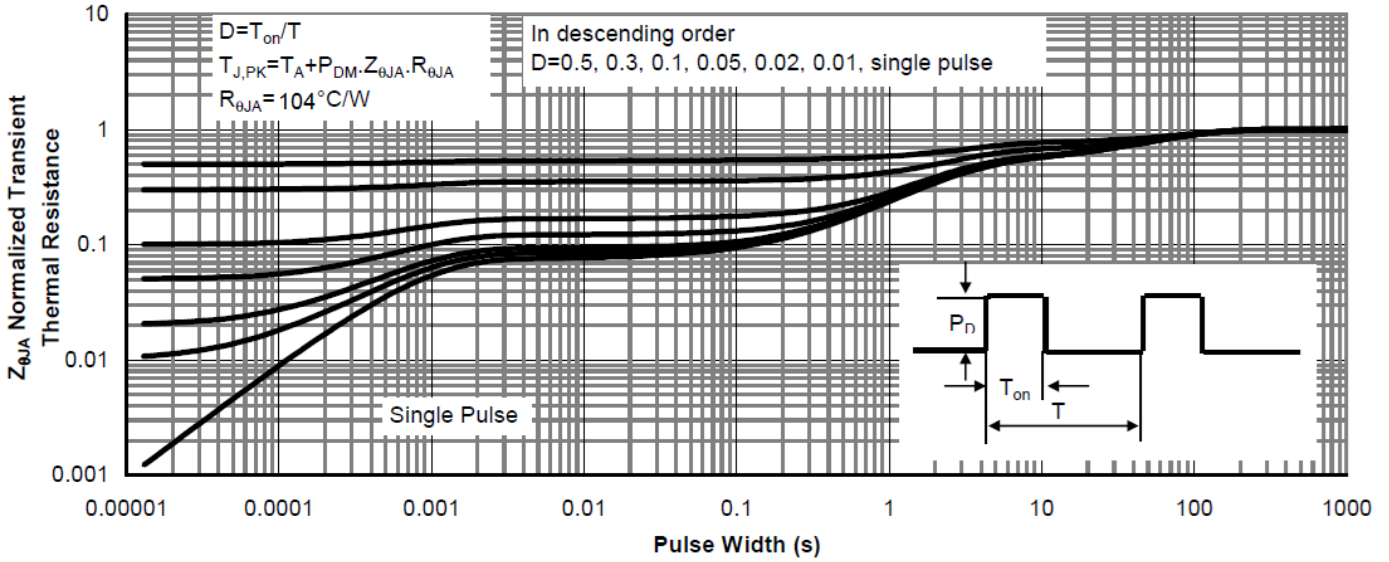
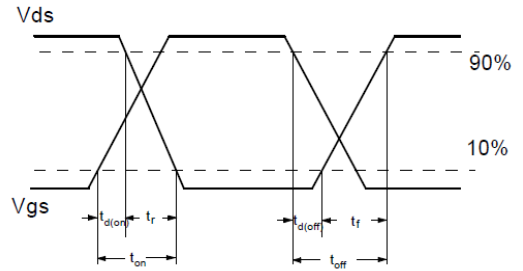
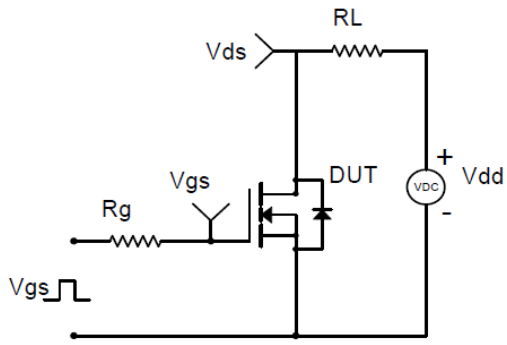
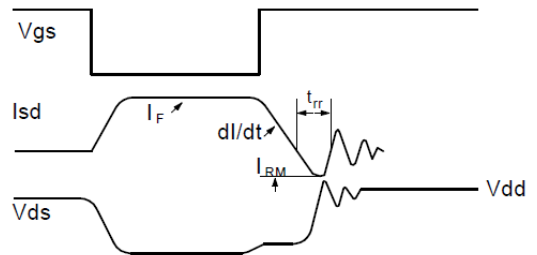
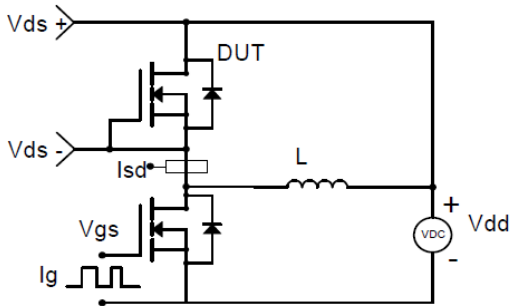

Figure9. Normalized Maximum Transient Thermal Impedance



**Resistive Switching Test Circuit & Waveforms**



**Diode Recovery Test Circuit & Waveforms**

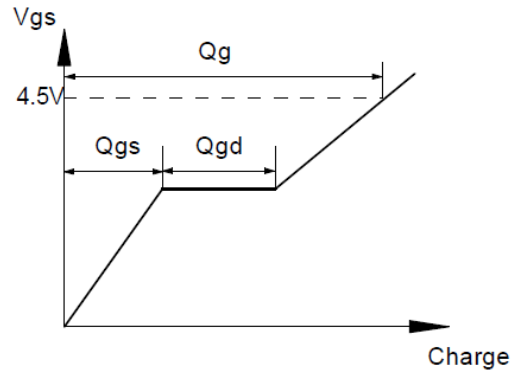
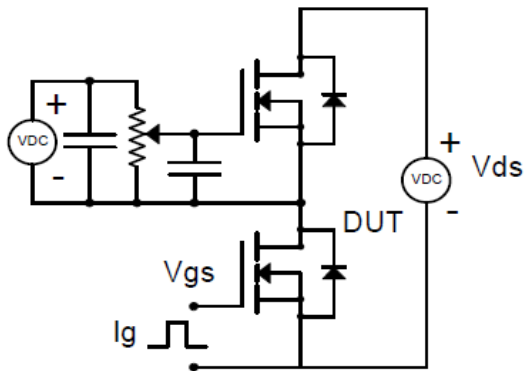

**Gate Charge Test Circuit & Waveform**

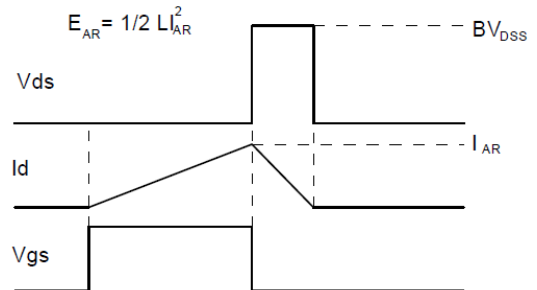
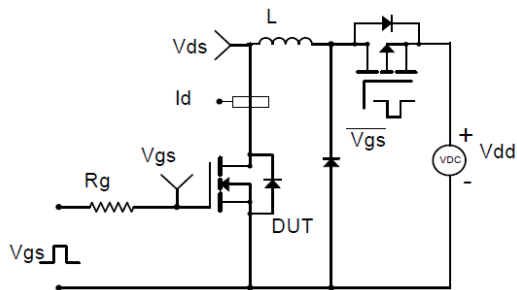

**Unclamped Inductive Switching (UIS) Test Circuit & Waveforms**

# ZXL3401A

## ■ SOT-23 Package Information

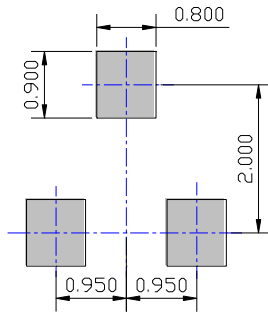
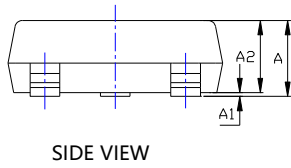
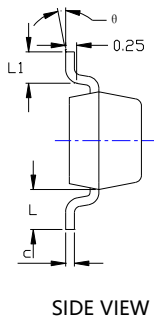
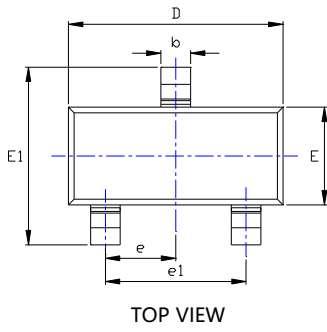

UNIT: mm

SYMBOL	DIMENSIONS			
	INCHES		Millimeter	
	MIN.	MAX.	MIN.	MAX.
A	0.035	0.045	0.900	1.150
A1	0.000	0.004	0.000	0.100
A2	0.035	0.041	0.900	1.050
b	0.012	0.020	0.300	0.500
c	0.004	0.008	0.100	0.200
D	0.110	0.118	2.800	3.000
E	0.047	0.055	1.200	1.400
E1	0.089	0.100	2.250	2.550
e	0.037TYP		0.950TYP	
e1	0.071	0.079	1.800	2.000
L	0.022REF		0.550REF	
L1	0.012	0.020	0.300	0.500
θ	0°	8°	0°	8°

NOTE:  
 1. PACKAGE BODY SIZES EXCLUDE MOLD FLASH AND GATE BURRS.  
 2. TOLERANCE 0.1mm UNLESS OTHERWISE SPECIFIED.  
 3. THE PAD LAYOUT IS FOR REFERENCE PURPOSES ONLY.