

1.View and size(视图及尺寸)

Main technical indicators(主要技术指标)	
1.Mating (插拔次数)	5000
2.Working Temperature (温度)	-55~+150 °C
3.IP Rating (防护级别)	IP 50
4.Diameter of socket end(插合端直径)	φ0.5
5.Testing Voltage (测试电压)	850V
6.Working Voltage (工作电压)	650V
7.Rated Current (额定电流)	2.5A
8.Shell material(壳体材质)	Brass (chromium plating) shell and chuck nut/(nickel plating) pin sleeve and middleware/黄铜(镀铬)外壳和夹头螺母/(镀铬)插销套和中间件
9.Pin Material(插针材料)	Copper alloy gold plating(铜合金镀金)
10.Insulator material(绝缘体材质)	PPS

Sum up(总结)

Series(系列)	B
Shell style/model (外壳样式/型号)	THG: Elbow plug, cable collet/电缆夹头弯头
Button (按键)	A button(一个按键)
Termination type (终止类型)	Male solder(公焊锡)
Line diameter awg(线材直径)	34AWG-28AWG
Cable diameterφ (电缆直径)	φ4.3-5.2MM
Matching parts(配件)	ZGG.0B.P06.CLL

Location pin combination(定位销组合)

编号 Number	Number of positioning pins(定位销数量)	Angle(角度)	Series(系列)-0B
G	One(1)		(Zero degrees)0°
A	Two(2)	A	Thirty degrees(30°)
B	Two(2)		Sixty degrees(60°)
C	Two(2)		Ninety degrees(90°)
D	Two(2)	β	135 degrees(135°)
E	Two(2)		145 degrees(145°)
F	Two(2)		155 degrees(155°)
J	Two(2)	γ	Forty-five degrees(45°)
K	Two(2)		Seventy degrees(70°)
L	Two(2)		80 degrees(80°)

	A	B	C√	ANGLE	
5-10	±0.02	±0.05	±0.1	0°-30°	±0.1°
50-100	±0.1	±0.15	±0.2	61°-90°	±0.5°
50-100	±0.15	±0.2	±0.25		
100-	±0.15%	±0.20%	±0.25%		

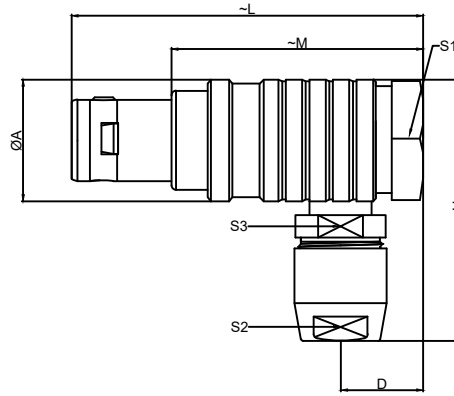

	A	D	H	L	M	S1	S2	S3
MM	11	6.5	26	31.6	21.6	10	7	8
in	0.4331	0.256	1.0236	1.2441	0.8504	0.3937	0.2756	0.315

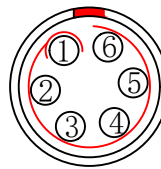

Welded surface
(焊接面)

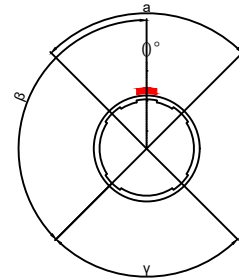

Positive view
(正视图)

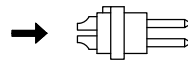

Solder core
(焊接型公胶芯)

TH G. 0B. P06. C L A D 52

Model(型号)

Positioning pin(定位销)

Series(系列)

Needle core configuration(针芯配置)

Outer casing(外壳)

Insulator(绝缘体)

Needle core(针芯)

Type of clamp(线夹类型)

Cable diameter(电缆直径)

DESIGNED(设计)		DATE(日期)		SCALE(比例)	N/A(不适用)	MODEL TYPE 型号类型: THG.0B.P06.CLAD52
CHECKED(校对)		DATE(日期)		VIEW(视图)		PART NO. 0B6-core plug 名称: 0B6芯插头
APPROVED(审核)		DATE(日期)		UNIT(单位)	MM	DWG NO.:
REVISIONS				MATERIAL (材料)		
www.helloxkb.com www.helloxkb.cn			XKB INDUSTRIAL PRECISION CO.,LIMITED			WEIGHT(重量) SHEET(表) REVISION(修订) 1/1 A0