

## SOT-23 Plastic-Encapsulate Transistors

### Features

- Complementary to MMBT3904
- Power dissipation of 200mW
- High stability and high reliability
- Meets MSL level 1, per J-STD-020, LF maximum peak of 260°C

### Mechanical Data

- Case: SOT-23  
Molding compound meets UL 94V-0 flammability rating, RoHS-compliant, halogen-free
- Terminals: Solder plated, solderable per MIL-STD-750, Method 2026

### Function Diagram

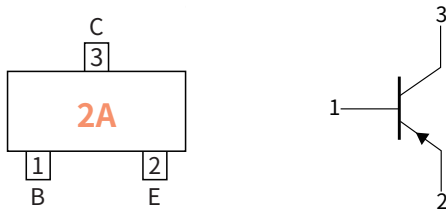

### Collector-Base Voltage

VCBO -40V

### Collector Current

-0.2 Ampere

### SOT-23

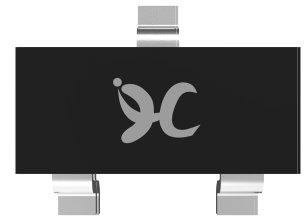

### Maximum Ratings (Ta=25°C Unless otherwise specified)

PARAMETER	SYMBOL	UNIT	VALUE
Collector-Base Voltage	$V_{CBO}$	V	-40
Collector-Emitter Voltage	$V_{CEO}$		-40
Emitter-Base Voltage	$V_{EBO}$		-5.0
Collector Current	$I_C$	A	-0.2
Collector Power Dissipation	$P_C$	mW	200
Storage temperature	$T_{stg}$	°C	-55 ~+150
Junction temperature	$T_j$	°C	-55 ~+150
Typical Thermal Resistance	$R_{\theta J-A}$	°C /W	625

### Electrical Characteristics (Ta=25°C Unless otherwise noted)

PARAMETER	SYMBOL	UNIT	Condition	Min	Max
Collector-Base Breakdown Voltage	$V_{(BR)CBO}$	V	$I_C = -10\mu A, I_E = 0$	-40	—
Collector-Emitter Breakdown Voltage	$V_{(BR)CEO}$		$I_C = -1.0mA, I_B = 0$	-40	—
Emitter-Base Breakdown Voltage	$V_{(BR)EBO}$		$I_E = -10\mu A, I_C = 0$	-5.0	—
Collector-Base cut-off current	$I_{CBO}$	nA	$V_{CB} = -40V, I_E = 0$	—	-50
Collector cut-off current	$I_{CEX}$		$V_{CE} = -30V, V_{EB(off)} = -3.0V$	—	-100
Emitter-Base cut-off current	$I_{EBO}$		$V_{EB} = -5.0V, I_C = 0$	—	-100
DC Current Gain	$h_{FE}$	—	$V_{CE} = -1.0V, I_C = -10mA$	100	300
			$V_{CE} = -1.0V, I_C = -50mA$	60	—
			$V_{CE} = -1.0V, I_C = -100mA$	30	—
Collector-Emitter Saturation Voltage	$V_{CE(sat)}$	V	$I_C = -50mA, I_B = -5mA$	—	-0.30
Base-Emitter Saturation Voltage	$V_{BE(sat)}$	V	$I_C = -50mA, I_B = -5mA$	—	-0.95
Delay time	$t_d$	ns	$V_{CC} = -3V, V_{BE(off)} = -0.5V, I_C = -10mA, I_{B1} = I_{B2} = -1mA$	—	35
Rise time	$t_r$			—	35
Storage time	$t_s$			—	225
Fall time	$t_f$			—	75

## ● Classification Of $h_{FE}$

RANK	L	H
Range	100-200	200-300

## ● Small-signal Characteristics

ITEM	SYMBOL	Condition	UNIT	Min	Max
Transition frequency	$f_T$	$I_C=-10mA, V_{CE}=-20V, f=100MHz$	MHz	300	—

## ● Ordering Information

PACKAGE	PACKAGE CODE	UNIT WEIGHT(g)	REEL(pcs)	BOX(pcs)	CARTON(pcs)	DELIVERY MODE
SOT-23	R1	0.008	3000	30000	120000	7"

## ● Ratings And Characteristics Curves (Ta=25°C Unless otherwise specified)

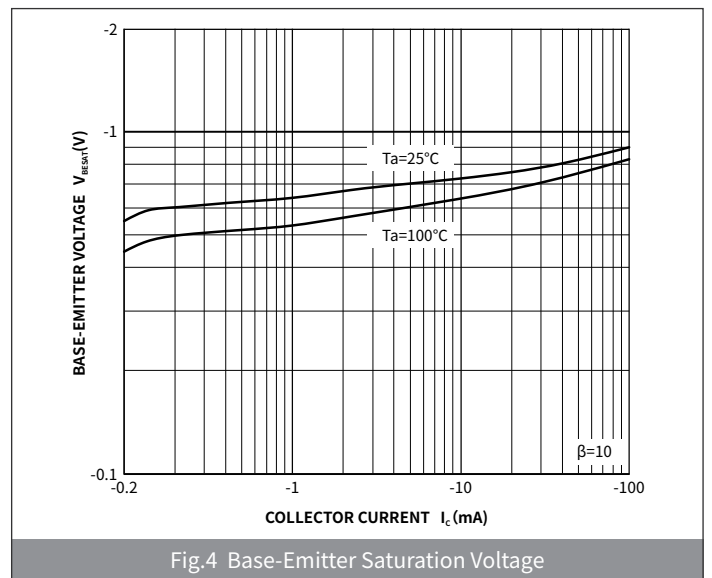
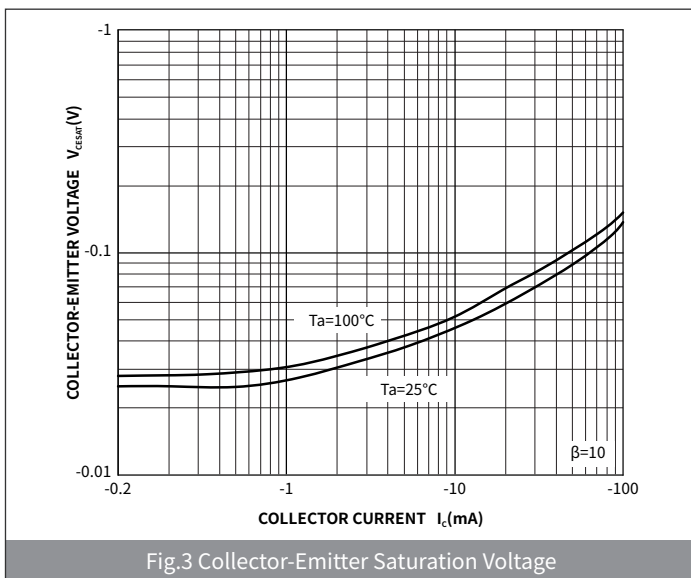
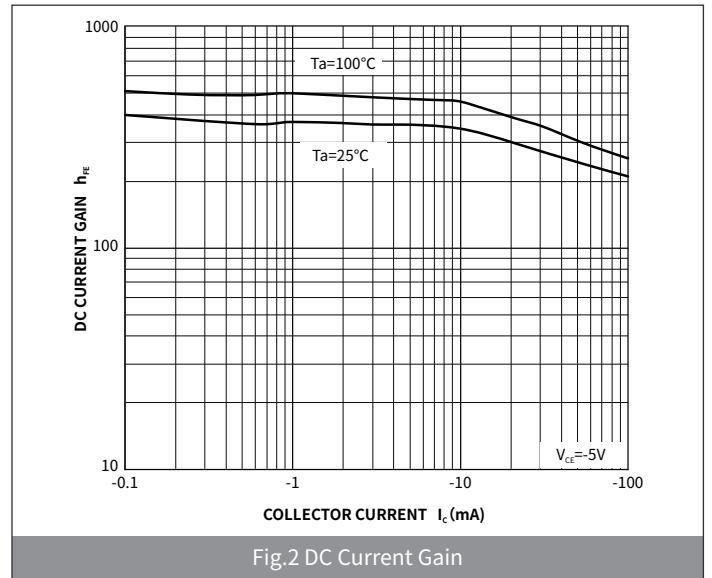
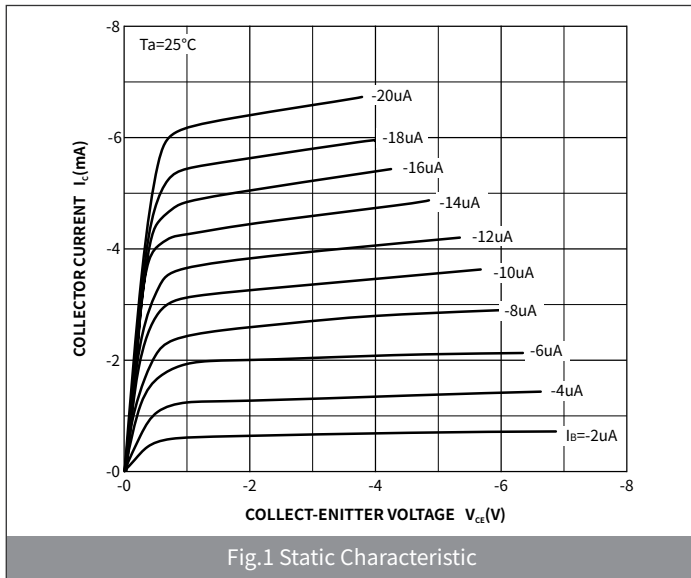

● Ratings And Characteristics Curves (Ta=25°C Unless otherwise specified)

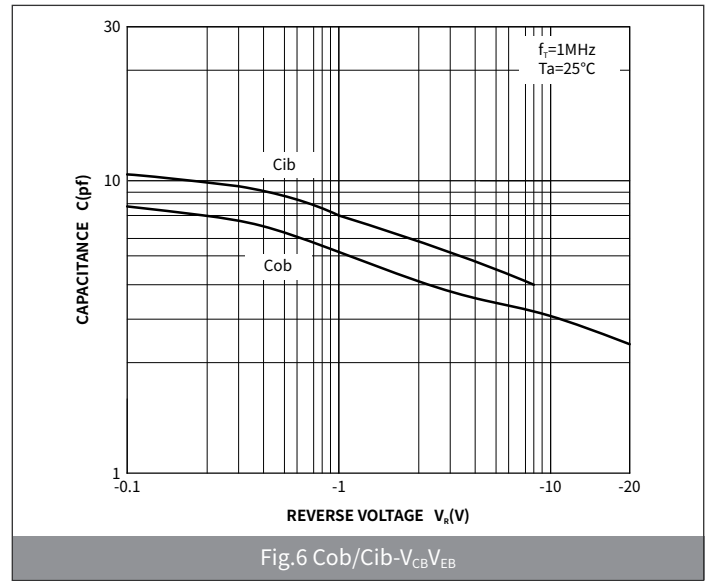
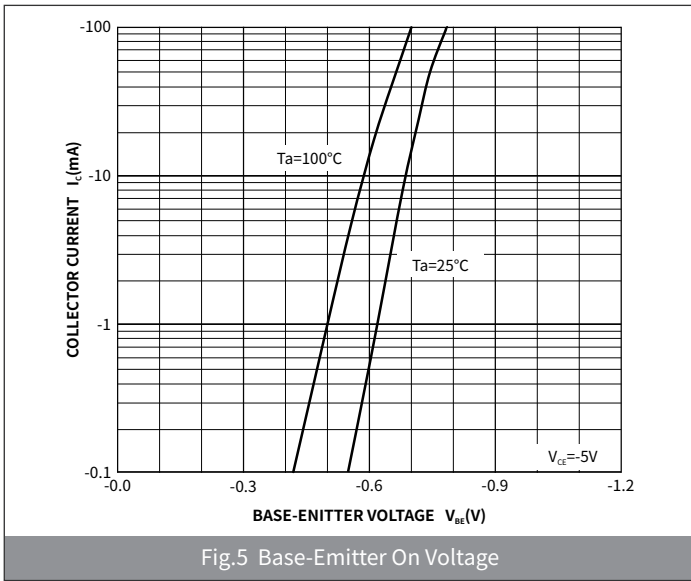

● Package Outline Dimensions (SOT-23)

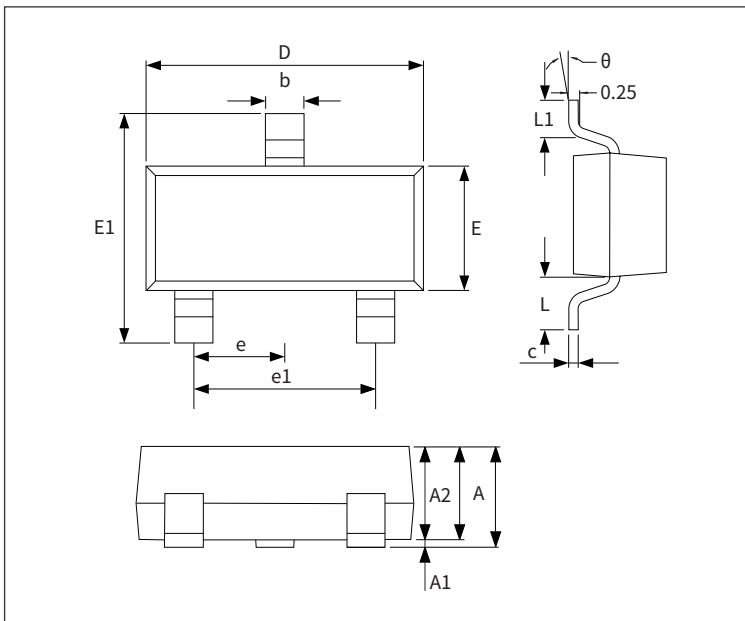

Symbol	Dimensions			
	Millimeters		Inches	
	Min.	Max.	Min.	Max.
A	0.90	1.15	0.035	0.045
A1	-	0.10	-	0.004
A2	0.90	1.05	0.035	0.041
b	0.30	0.50	0.012	0.020
c	0.10	0.20	0.004	0.008
D	2.80	3.00	0.110	0.118
E	1.20	1.40	0.047	0.055
E1	2.25	2.55	0.089	0.100
e	0.950TYP		0.037TYP	
e1	1.80	2.00	0.071	0.079
L	0.550REF		0.022REF	
L1	0.30	0.50	0.012	0.020
θ	-	8°	-	8°

● Suggested Pad Layout

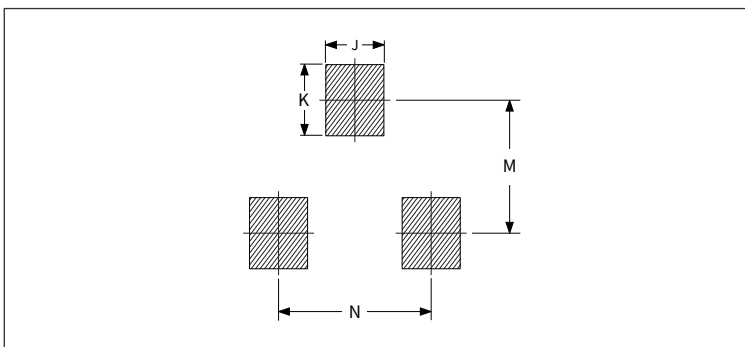

Symbol	Dimensions			
	Millimeters		Inches	
	Min.	Max.	Min.	Max.
J	0.75	0.85	0.030	0.033
K	0.85	0.95	0.033	0.037
M	1.95	2.05	0.077	0.081
N	1.85	1.95	0.073	0.077