

# RoHS

| REV | ECN NO. | DESCRIPTION | DESIGN | APPROVAL | DATE       |
|-----|---------|-------------|--------|----------|------------|
| A1  | NEW     | 更换图框        |        |          | 2023.11.25 |

技术要求:

1. 打铜底0.5-1 $\mu$ m, 镍2-2.5 $\mu$ m, 哑锡3-5 $\mu$ m。
2. 垫片铆好后不得有松动现象。
3. 插脚尖部符合可焊性要求。
4. 螺纹需符合通止规/止针要求。
5. 螺纹扭矩: 2.8Nm。
6. 额定扭矩: 100A。
7. X为重点测量尺寸。

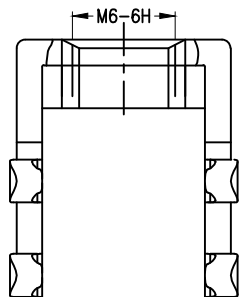
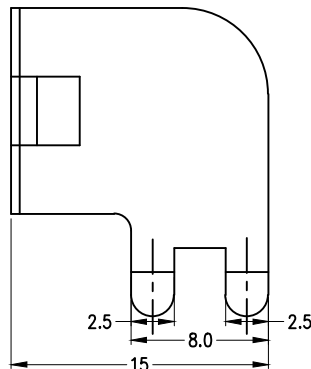
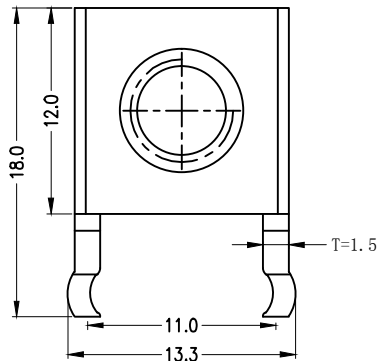
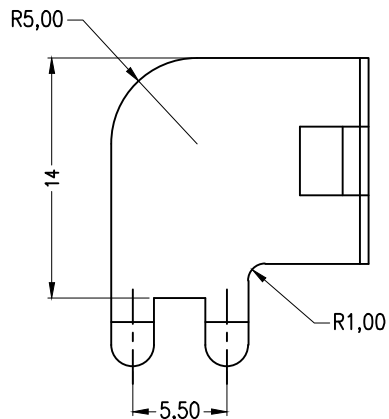
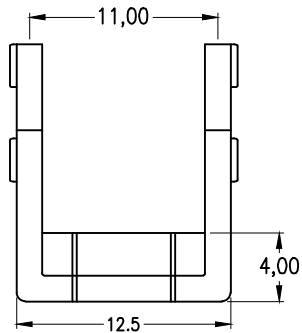

|            |        |
|------------|--------|
| >30 ±0.40  | x.°±   |
| 6-30 ±0.30 | .x°±   |
| 0-6 ±0.20  | .xx°±  |
| ANGLES ±1° | .xxx°± |
| UNITS:     | mm     |

|                               |            |
|-------------------------------|------------|
| PART NO: TTR64125180-1500     |            |
| TITLE: PCB SOLDERING TERMINAL |            |
| APPD                          |            |
| CHKD                          |            |
| DRAW                          | Wang       |
| DATE                          | 2023.11.27 |

|                   |  |
|-------------------|--|
| <b>XFCN</b> 兴飞连接器 |  |
| 0769-82001899     |  |
| www.xfconn.com    |  |
| DWG NO: /         |  |

|    |    |      |        |    |
|----|----|------|--------|----|
| 2  | 垫片 |      | SPCC   | 1  |
| 1  | 插脚 |      | T2(Y2) | 1  |
| 序号 | 名称 | 零件编号 | 材质     | 数量 |

THESE DRAWINGS AND SPECIFICATIONS ARE THE PROPERTY OF XFCN AND SHALL NOT BE REPRODUCED, COPIED OR CUED IN ANY MANNER WITHOUT THE PRIOR WRITTEN CONSENT OF XFCN

|       |      |       |     |
|-------|------|-------|-----|
| VIEW  |      |       |     |
| SCALE | NONE | SHEET | REV |
|       | 1:1  |       | A1  |