

■ PRODUCT CHARACTERISTICS

VDSS	700V
$R_{DS(on)typ}(V_{GS} = 10V)$	0.8Ω
Qg@type	32.5nC
ID	12A

■ APPLICATIONS

- High frequency switching mode power supply
- Electronic ballast
- UPS

■ FEATURES

- * Ultra low gate charge
- * Fast switching capability
- * Avalanche energy tested
- * Improved dv/dt capability, high ruggedness

Symbol

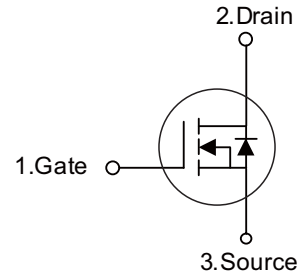

■ ORDER INFORMATION

Order codes		Package	Packing
Halogen-Free	Halogen		
N/A	MOT12N70F	TO-220F	50 pieces/Tube
N/A	MOT12N70A	TO-220	50 pieces/Tube

■ ABSOLUTE MAXIMUM RATINGS ($T_C = 25^\circ\text{C}$, unless otherwise specified)

PARAMETER	SYMBOL	RATINGS	UNIT
Drain-Source Voltage	V_{DSS}	700	V
Gate-Source Voltage	V_{GSS}	±30	V
Drain Current	Continuous	I_D	12
	Pulsed (Note 2)	I_{DM}	24
Avalanche Energy	Single Pulsed (Note 3)	E_{AS}	103
Peak Diode Recovery dv/dt (Note 4)	dv/dt	2.7	V/ns
Power Dissipation	TO-220	P_D	150
	TO-220F		36
Junction Temperature	T_J	+150	°C
Storage Temperature	T_{STG}	-55 ~ +150	°C

Notes: 1. Absolute maximum ratings are those values beyond which the device could be permanently damaged.

Absolute maximum ratings are stress ratings only and functional device operation is not implied.

2. Repetitive Rating : Pulse width limited by maximum junction temperature
3. $L = 10\text{mH}$, $I_{AS} = 4.53\text{A}$, $V_{DD} = 50\text{V}$, $R_G = 25\Omega$, Starting $T_J = 25^\circ\text{C}$
4. $I_{SD} \leq 12\text{A}$, $di/dt \leq 200\text{A/s}$, $V_{DD} \leq BV_{DSS}$ Starting $T_J = 25^\circ\text{C}$

■ ELECTRICAL CHARACTERISTICS (T_c=25°C, unless otherwise noted)

PARAMETER	SYMBOL	TEST CONDITIONS	MIN	TYP	MAX	UNIT
Off characteristics						
Drain-Source Breakdown Voltage	BV _{DSS}	V _{GS} =0V, I _D =250μA	700	-	-	V
Drain-Source Leakage Current	I _{DSS}	V _{DS} =700V, V _{GS} =0V	-	-	10	μA
Gate-Source Leakage Current	I _{GSS}	V _{GS} =±30V, V _{DS} =0V	-	-	±100	nA
On characteristics						
Gate Threshold Voltage	V _{GS(TH)}	V _{DS} =V _{GS} , I _D =250μA	2.0	-	4.0	V
Static Drain-Source On-State Resistance	R _{DS(ON)}	V _{GS} =10V, I _D =6.0A	-	0.8	0.9	Ω
Dynamic characteristics						
Input Capacitance	C _{ISS}	V _{DS} =25V, V _{GS} =0V, f=1MHz	-	1820	-	pF
Output Capacitance	C _{OSS}		-	147	-	pF
Reverse Transfer Capacitance	C _{RSS}		-	4.6	-	pF
Switching characteristics						
Total Gate Charge	Q _G	V _{DS} =100V, I _D =12A, V _{GS} =10V I _G =1mA (Note1,2)	-	32.5	-	nC
Gate-Source Charge	Q _{GS}		-	12.5	-	nC
Gate-Drain Charge	Q _{GD}		-	7	-	nC
Turn-On Delay Time	t _{D(ON)}	V _{DD} =100V, I _D =12A, R _G =25Ω (Note1,2)	-	26	-	ns
Turn-On Rise Time	t _R		-	19	-	ns
Turn-Off Delay Time	t _{D(OFF)}		-	83	-	ns
Turn-Off Fall Time	t _F		-	31	-	ns
Source-drain diode ratings and characteristics						
Maximum Body-Diode Continuous Current	I _S		-	-	12	A
Maximum Body-Diode Pulsed Current	I _{SM}		-	-	24	A
Drain-Source Diode Forward Voltage	V _{SD}	V _{GS} =0V, I _S =12A	-	-	1.4	V
Reverse Recovery Time	t _{rr}	V _{GS} =0V, I _S =12A, di/dt=100A/μs	-	400	-	ns
Reverse Recovery Charge	Q _{rr}		-	5.8	-	μC

Notes: 1. Pulse Test : Pulse width ≤300μs, Duty cycle ≤ 2%.
 2. Essentially independent of operating temperature.

■ TEST CIRCUITS AND WAVEFORMS

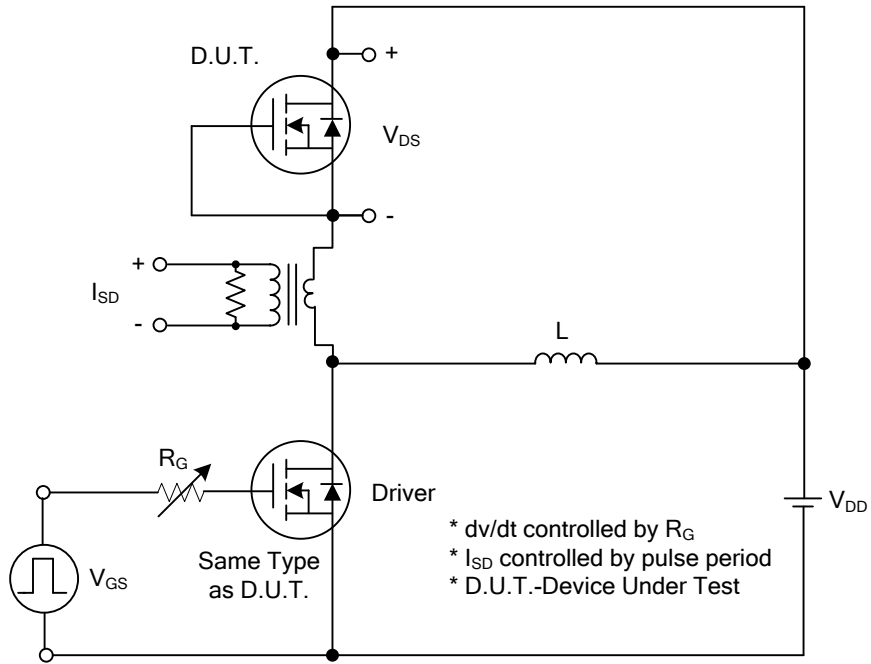

Peak Diode Recovery dv/dt Test Circuit

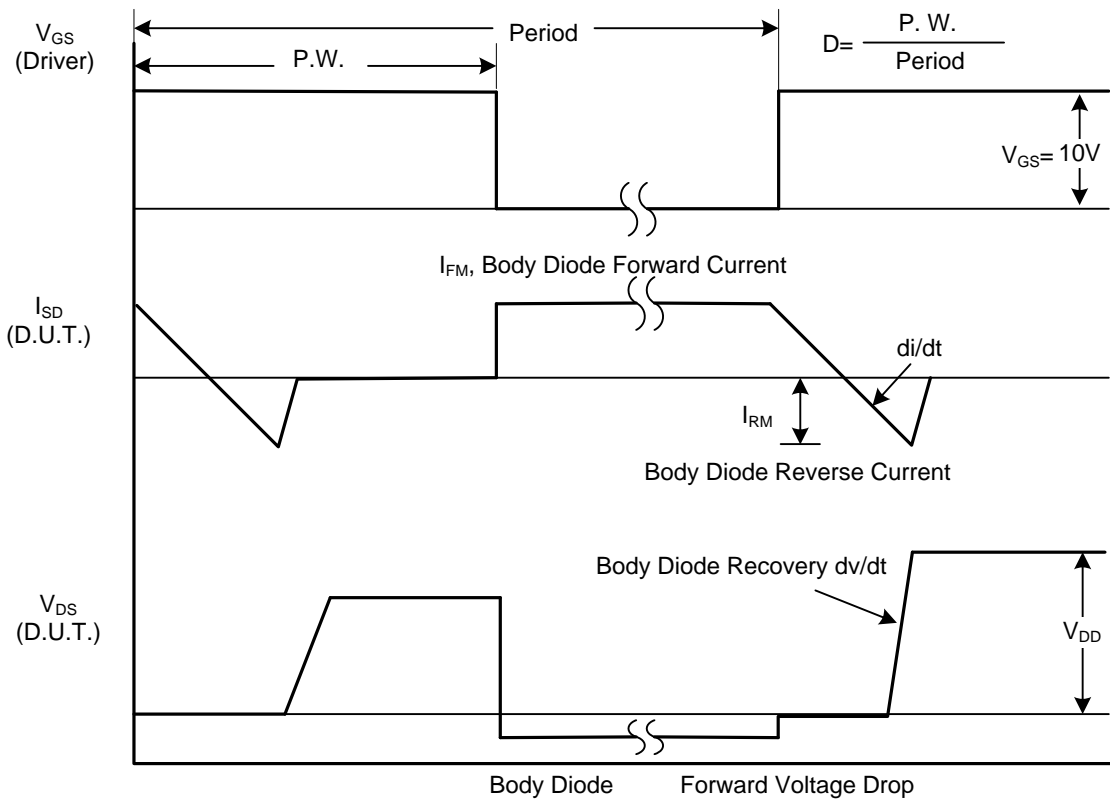

Peak Diode Recovery dv/dt Waveforms

■ TEST CIRCUITS AND WAVEFORMS(Cont.)

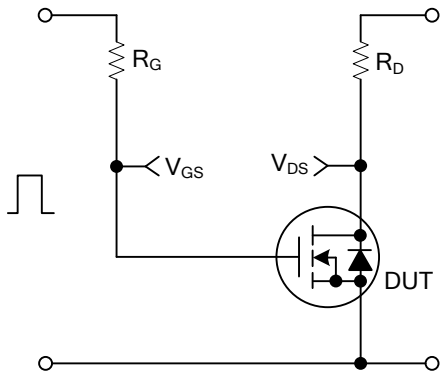

Switching Test Circuit

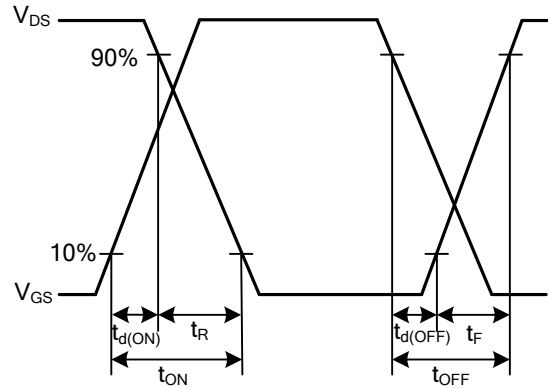

Switching Waveforms

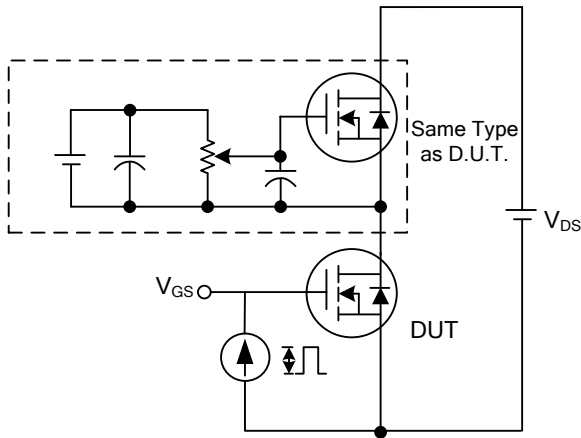

Gate Charge Test Circuit

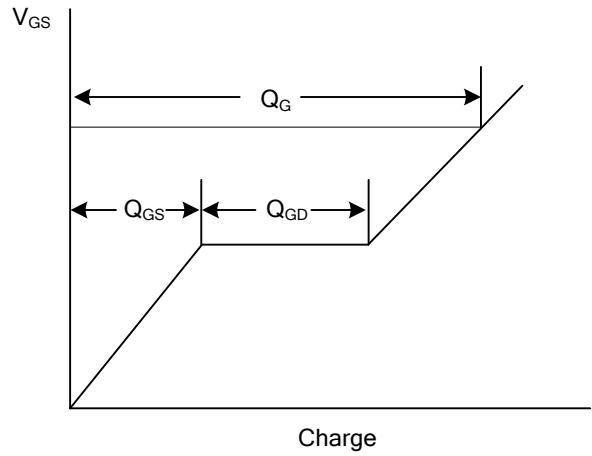

Gate Charge Waveform

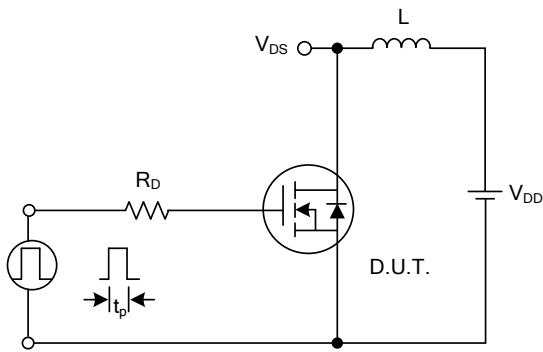

Unclamped Inductive Switching Test Circuit

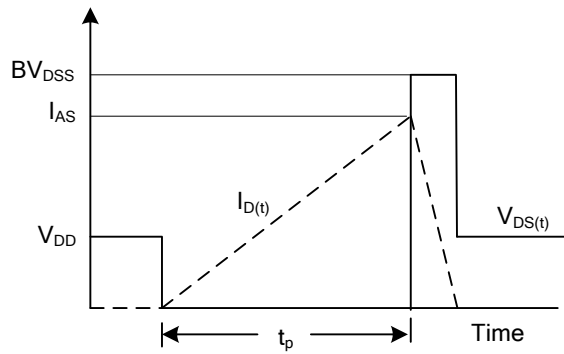

Unclamped Inductive Switching Waveforms

■ TYPICAL CHARACTERISTICS

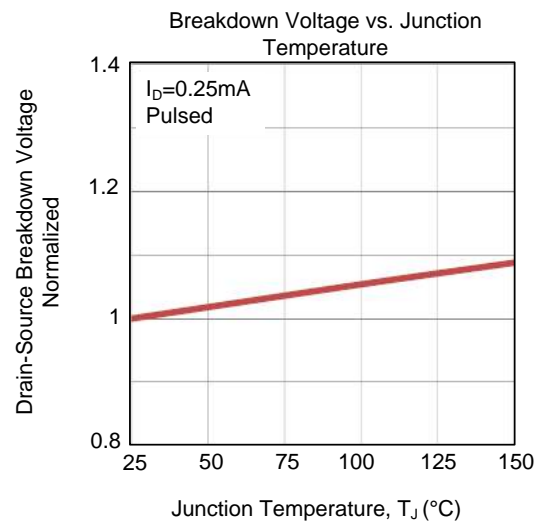
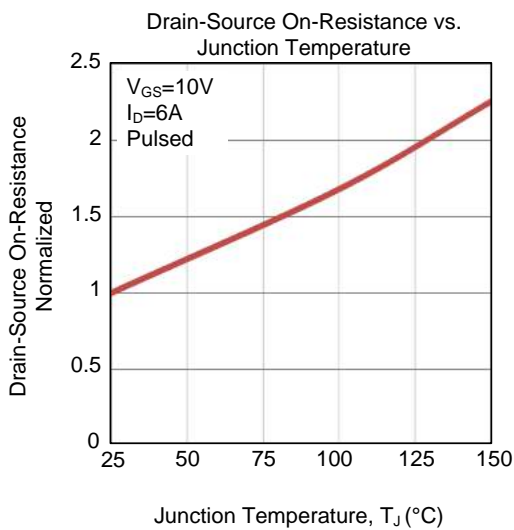
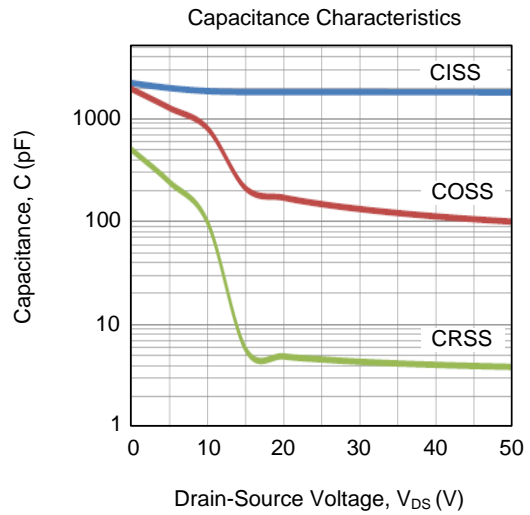
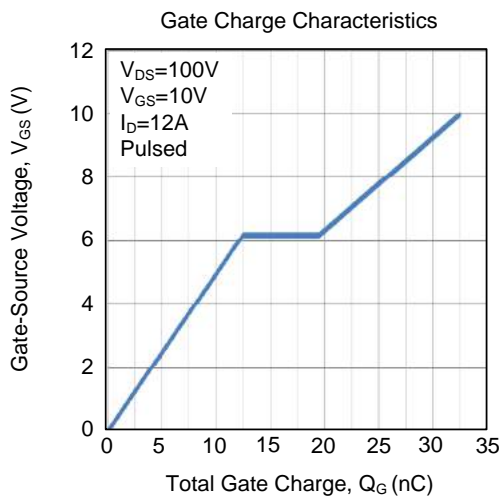
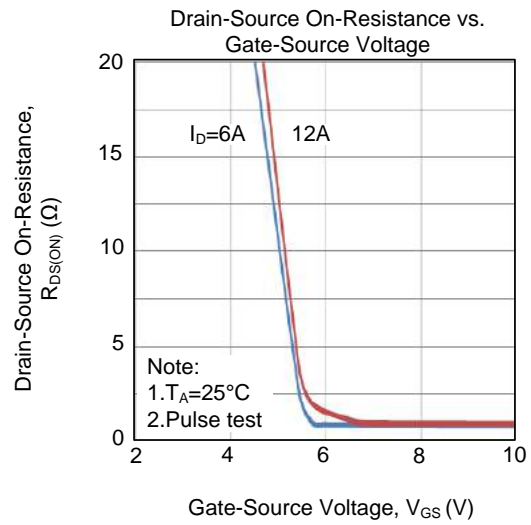
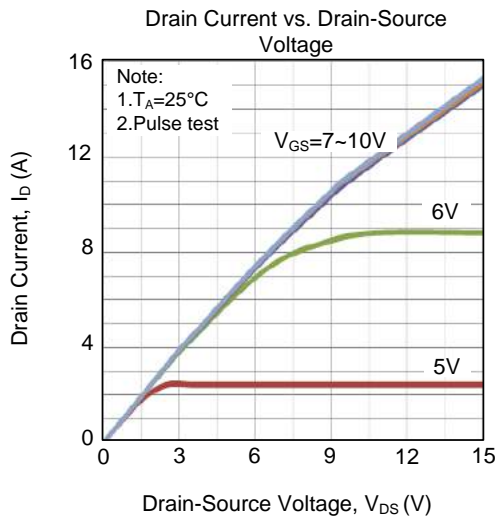

■ TYPICAL CHARACTERISTICS(Cont.)

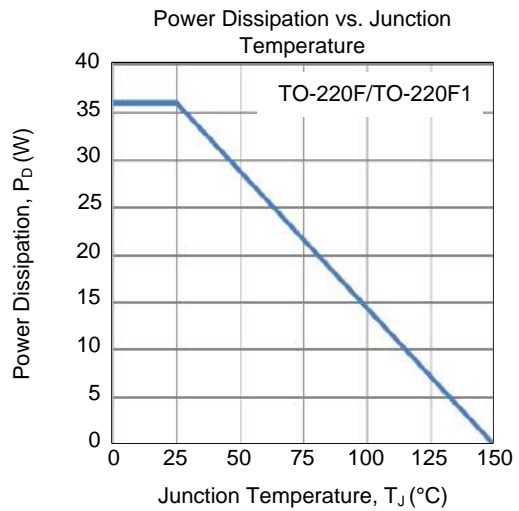
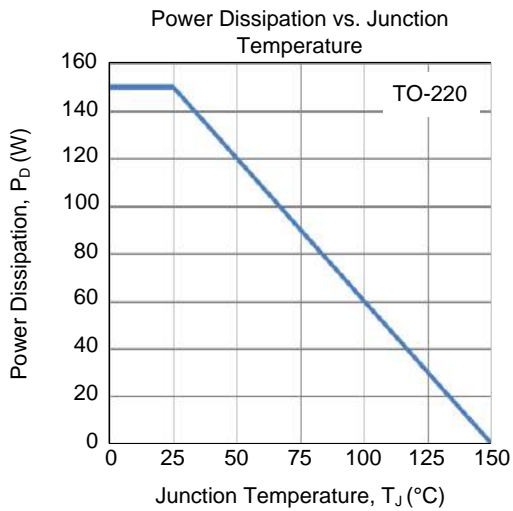
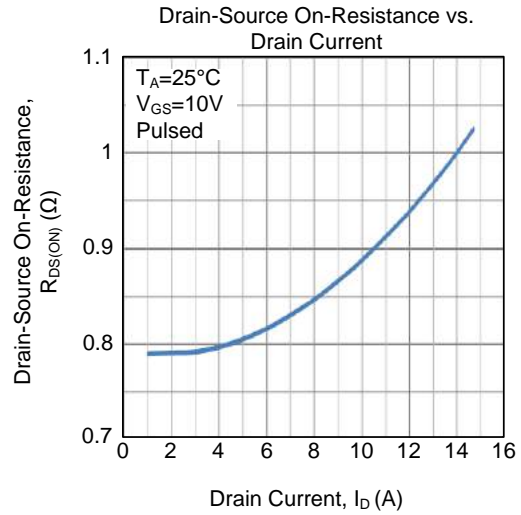
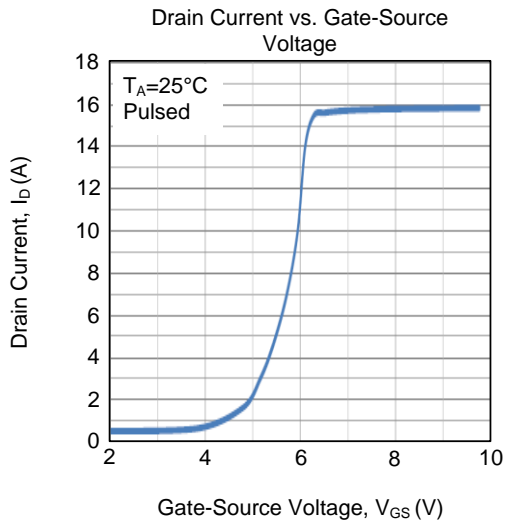
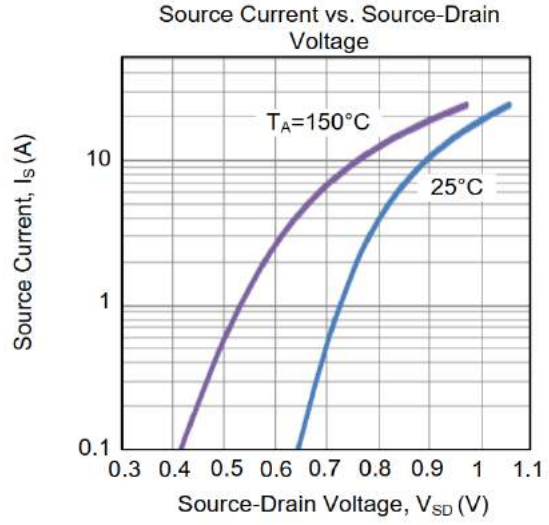
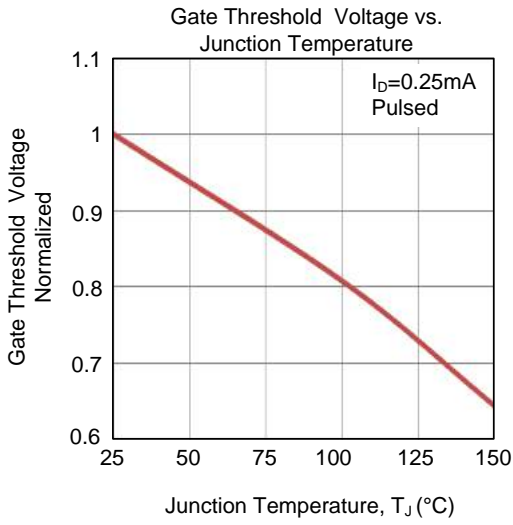

■ TO-220F-3L PACKAGE OUTLINE DIMENSIONS

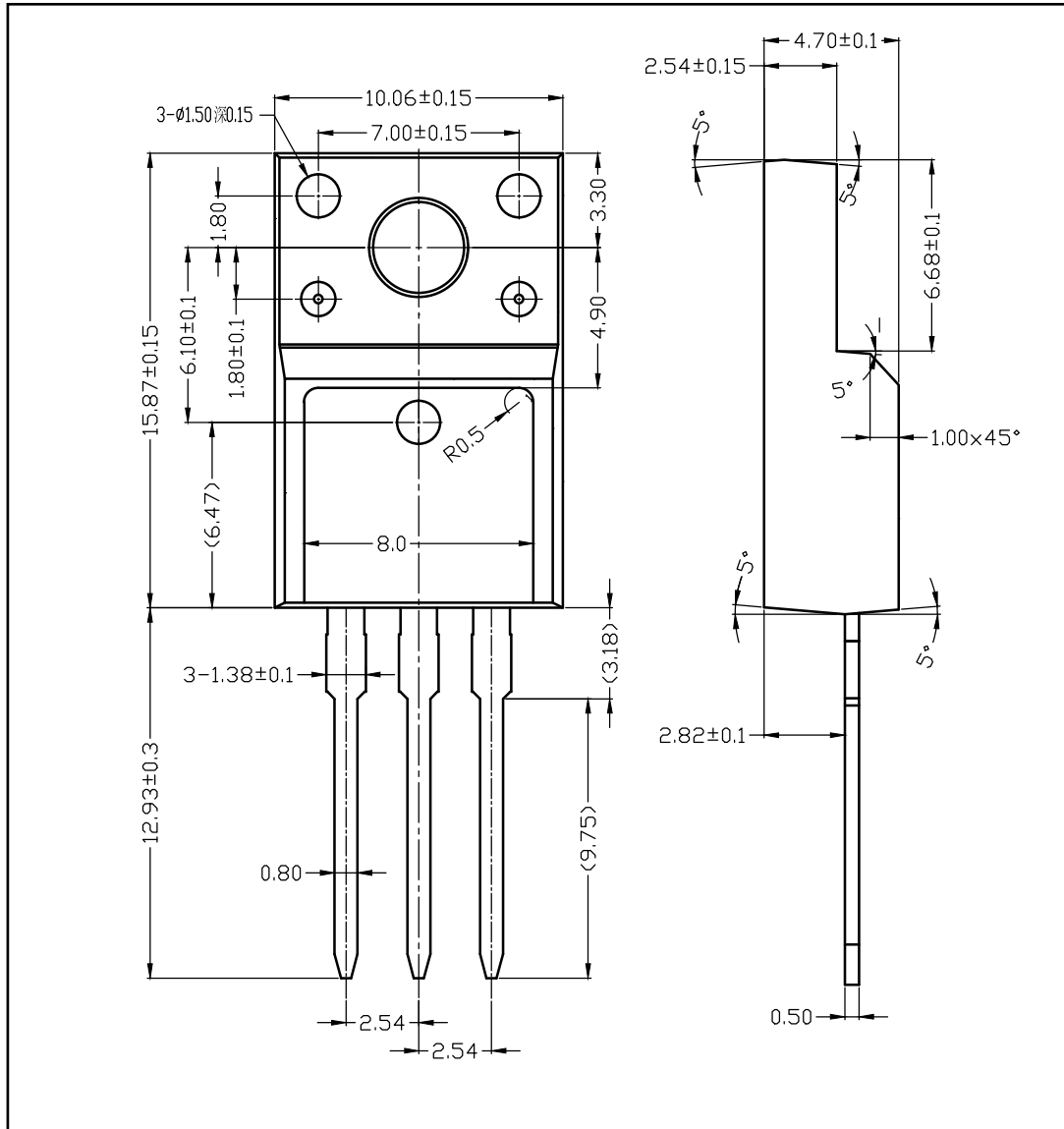

■ TO-220-3L PACKAGE OUTLINE DIMENSIONS

