

- ★ Green Device Available
- ★ Super Low Gate Charge
- ★ Excellent CdV/dt effect decline
- ★ Advanced high cell density Trench technology
- ★ 100% EAS Guaranteed

Product Summary



BVDSS	RDS(on)	ID
-60V	20mΩ	-45A

Description

The 50P06 is the high cell density trenched N-ch MOSFETs, which provide excellent RDS(on) and gate charge for most of the synchronous buck converter applications.

The 50P06 meet the RoHS and Green Product, requirement 100% EAS guaranteed with full function reliability approved.

TO252 Pin Configuration

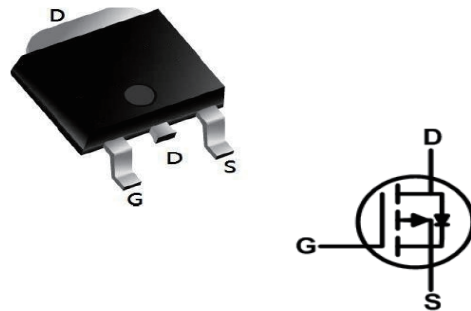

Absolute Maximum Ratings

Symbol	Parameter	Rating	Unit
V _{DS}	Drain-Source Voltage	-60	V
V _{GS}	Gate-Source Voltage	±20	V
I _{D@Tc=25°C}	Continuous Drain Current, -V _{GS} @ -10V ¹	-45	A
I _{D@Tc=100°C}	Continuous Drain Current, -V _{GS} @ -10V ¹	-27	A
I _{DM}	Pulsed Drain Current ²	-70	A
EAS	Single Pulse Avalanche Energy ³	113	mJ
I _{AS}	Avalanche Current	47.6	A
P _{D@Tc=25°C}	Total Power Dissipation ⁴	52.1	W
T _{STG}	Storage Temperature Range	-55 to 150	°C
T _J	Operating Junction Temperature Range	-55 to 150	°C

Thermal Data

Symbol	Parameter	Typ.	Max.	Unit
R _{θJA}	Thermal Resistance Junction-Ambient ¹	---	62	°C/W
R _{θJC}	Thermal Resistance Junction-Case ¹	---	2.4	°C/W

Electrical Characteristics ($T_J = 25^\circ\text{C}$ unless otherwise specified)

Symbol	Parameter	Test condition	Min.	Typ.	Max.	Units
BV_{DSS}	Drain-Source Breakdown Voltage	$V_{GS}=0V, I_D=-250\mu A$	-60	---	---	V
$\Delta BV_{DSS} / \Delta T_J$	BV_{DSS} Temperature Coefficient	Reference to 25°C , $I_D=-$	---	-0.035	---	$V/^\circ\text{C}$
$R_{DS(ON)}$	Static Drain-Source On-Resistance ²	$V_{GS}=-10V, I_D=-18A$	---	20	24	$m\Omega$
		$V_{GS}=-4.5V, I_D=-12A$	---	25	30	
$V_{GS(th)}$	Gate Threshold Voltage	$V_{GS}=V_{DS}, I_D=-250\mu A$	-1	---	-2.5	V
$\Delta V_{GS(th)}$	$V_{GS(th)}$ Temperature Coefficient		---	4.28	---	$mV/^\circ\text{C}$
I_{DSS}	Drain-Source Leakage Current	$V_{DS}=-48V, V_{GS}=0V, T_J=25^\circ\text{C}$	---	---	-1	μA
		$V_{DS}=-48V, V_{GS}=0V, T_J=55^\circ\text{C}$	---	---	-5	
I_{GSS}	Gate-Source Leakage Current	$V_{GS}=\pm 20V, V_{DS}=0V$	---	---	± 100	nA
g_{fs}	Forward Transconductance	$V_{DS}=-10V, I_D=-18A$	---	23	---	S
R_g	Gate Resistance	$V_{DS}=0V, V_{GS}=0V, f=1\text{MHz}$	---	7	---	Ω
Q_g	Total Gate Charge (-4.5V)	$V_{DS}=-20V, V_{GS}=-4.5V, I_D=-12A$	---	25	---	nC
Q_{gs}	Gate-Source Charge		---	6.7	---	
Q_{gd}	Gate-Drain Charge		---	5.5	---	
$T_{d(on)}$	Turn-On Delay Time	$V_{DD}=-15V, V_{GS}=-10V, R_g=3.3\Omega, I_D=-1A$	---	38	---	ns
T_r	Rise Time		---	23.6	---	
$T_{d(off)}$	Turn-Off Delay Time		---	100	---	
T_f	Fall Time		---	6.8	---	
C_{iss}	Input Capacitance	$V_{DS}=-15V, V_{GS}=0V, f=1\text{MHz}$	---	3635	---	pF
C_{oss}	Output Capacitance		---	224	---	
C_{rss}	Reverse Transfer Capacitance		---	141	---	

Diode Characteristics

Symbol	Parameter	Test condition	Min.	Typ.	Max.	Units
I_S	Continuous Source Current ^{1,5}	$V_G=V_b=0V$, Force Current	---	---	-45	A
I_{SM}	Pulsed Source Current ^{2,5}		---	---	-70	A
V_{SD}	Diode Forward Voltage ²	$V_{GS}=0V, I_S=-1A, T_J=25^\circ\text{C}$	---	---	-1	V

Note :

- The data tested by surface mounted on a 1 inch² FR-4 board with 20Z copper.
- The data tested by pulsed, pulse width $\leq 300\mu s$, duty cycle $\leq 2\%$
- The EAS data shows Max. rating. The test condition is $V_{DD}=-25V, V_{GS}=-10V, L=0.1mH, I_{AS}=-47.64A$
- The power dissipation is limited by 150°C junction temperature
- The data is theoretically the same as I_D and I_{DM} , in real applications, should be limited by total power dissipation.

P-Channel Typical Characteristics

Figure 1: Output Characteristics

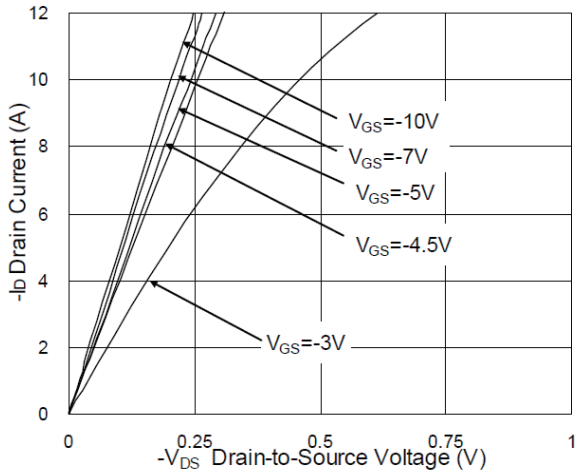

Figure 2: On-Resistance vs. G-S Voltage

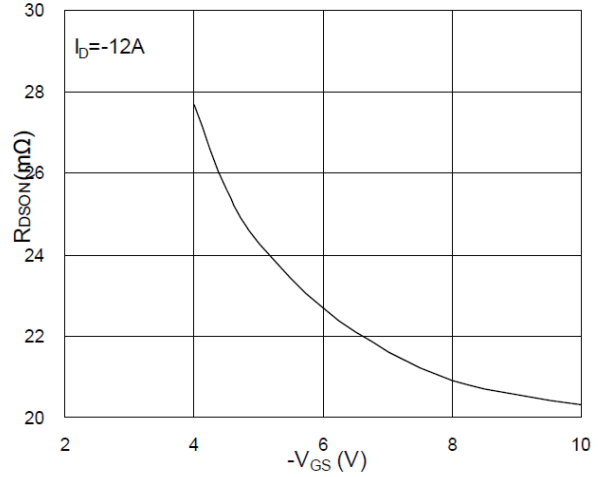

Figure 3: Forward Characteristics Of Reverse

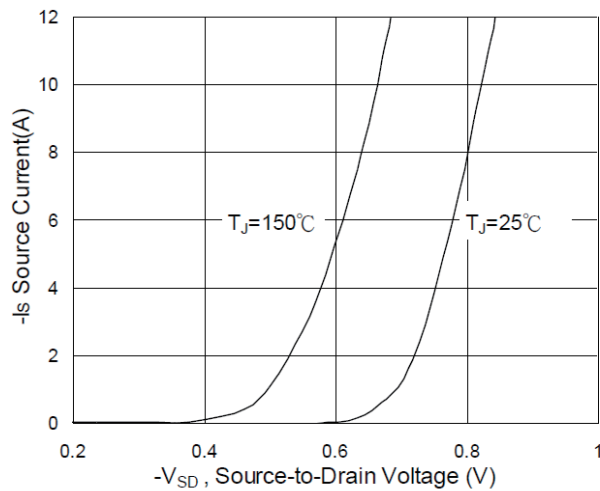

Figure 4: Gate-Charge Characteristics

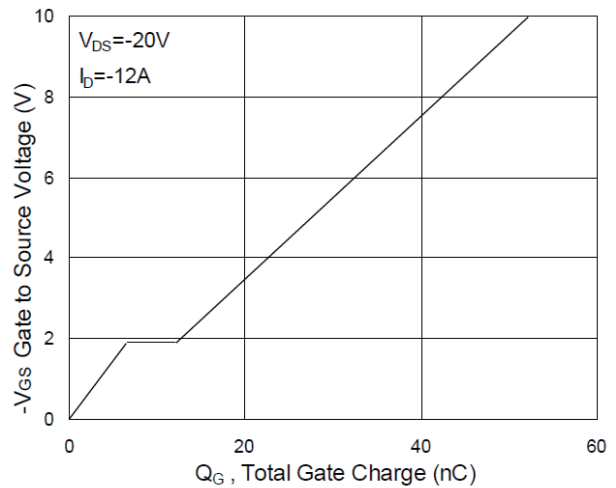

Figure 5: Normalized VGS(th) vs. TJ

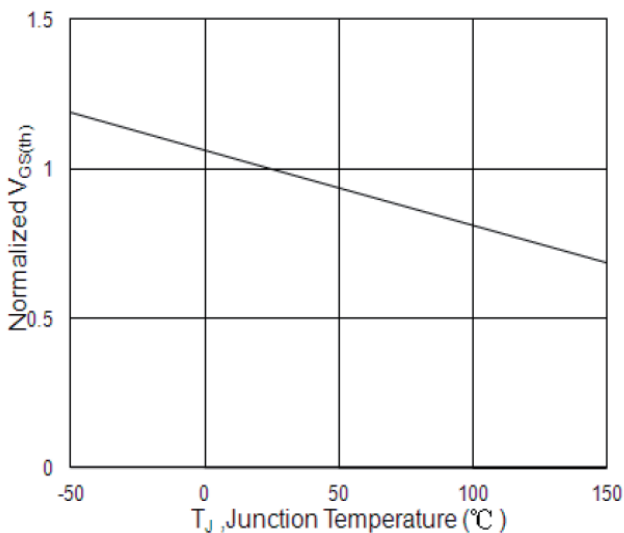
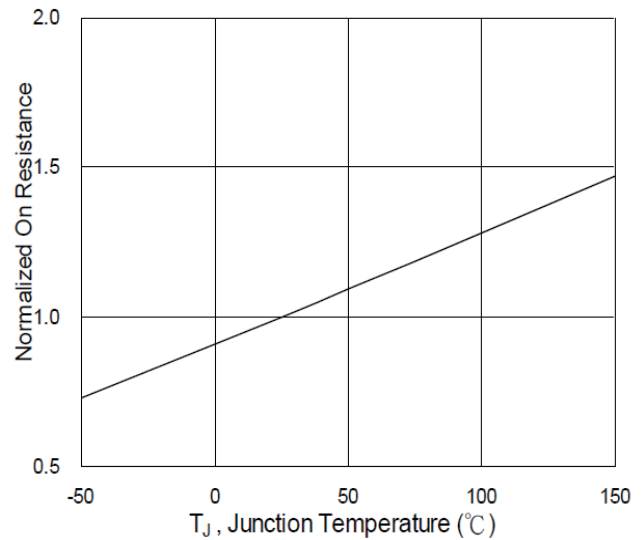

Figure 6: Normalized RDS(on) vs. TJ



Typical Performance Characteristics

Figure 7: Capacitance

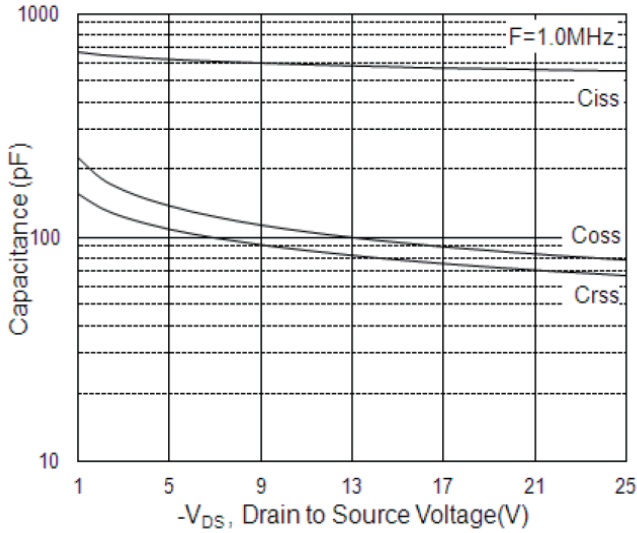

Figure 8: Safe Operating Area

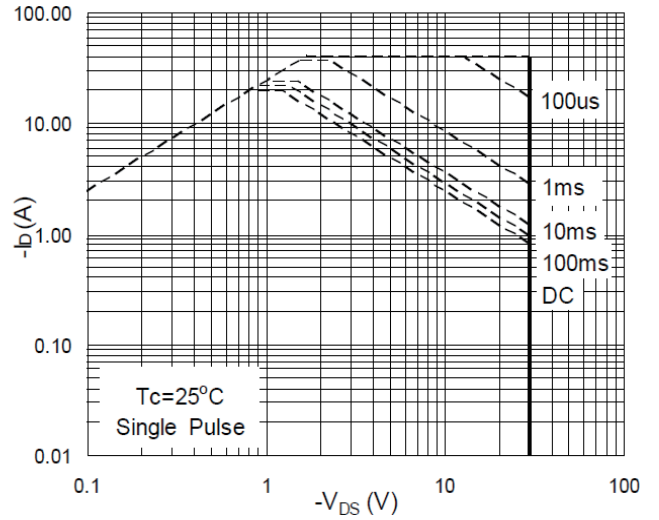

Figure 9: Normalized Maximum Transient Thermal Impedance

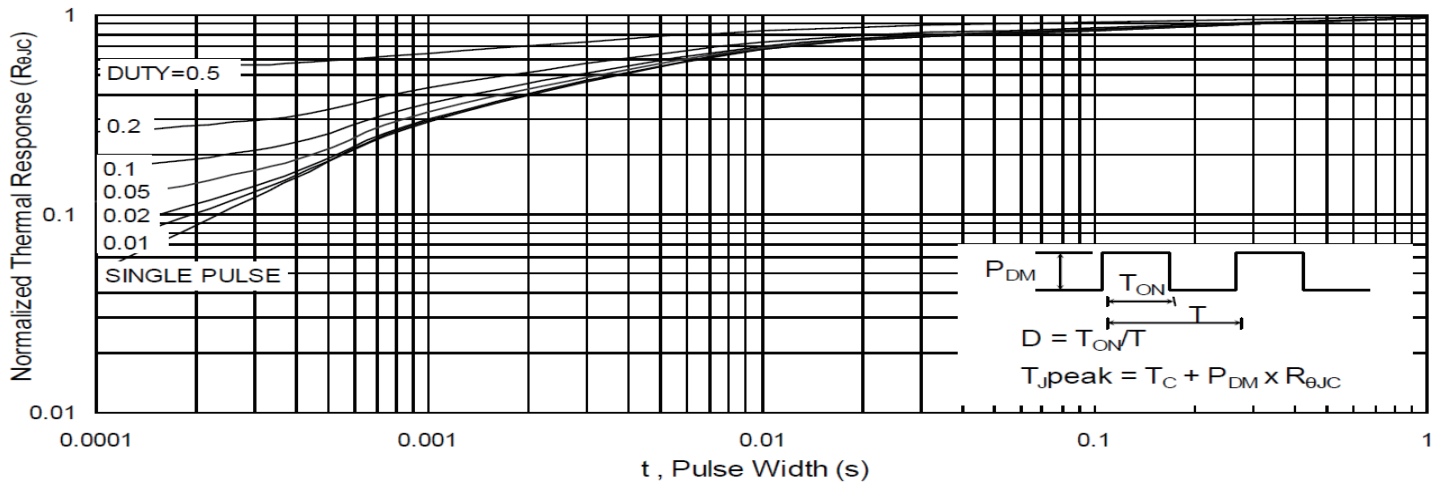

Figure 11: Switching Time Waveform

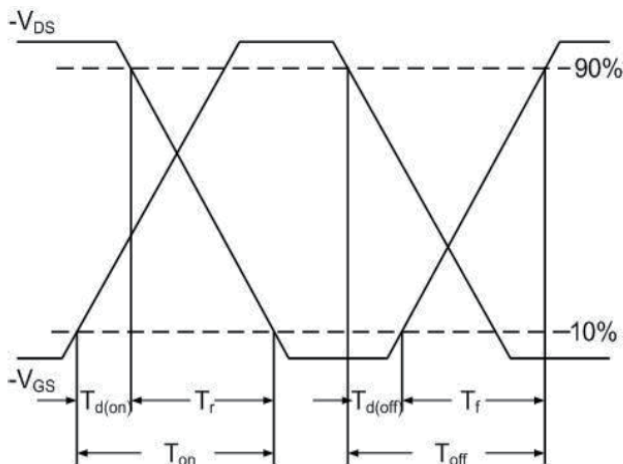
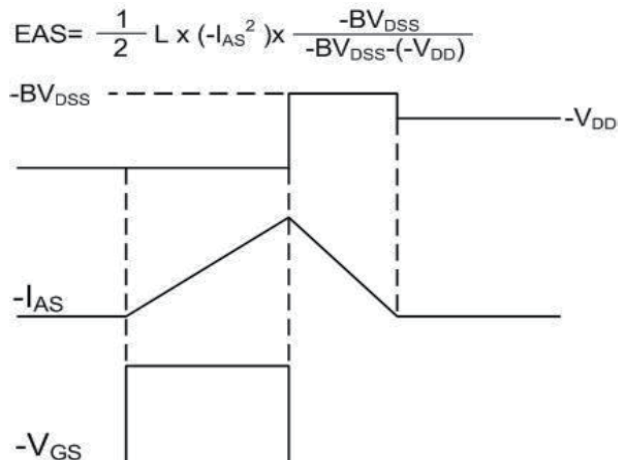
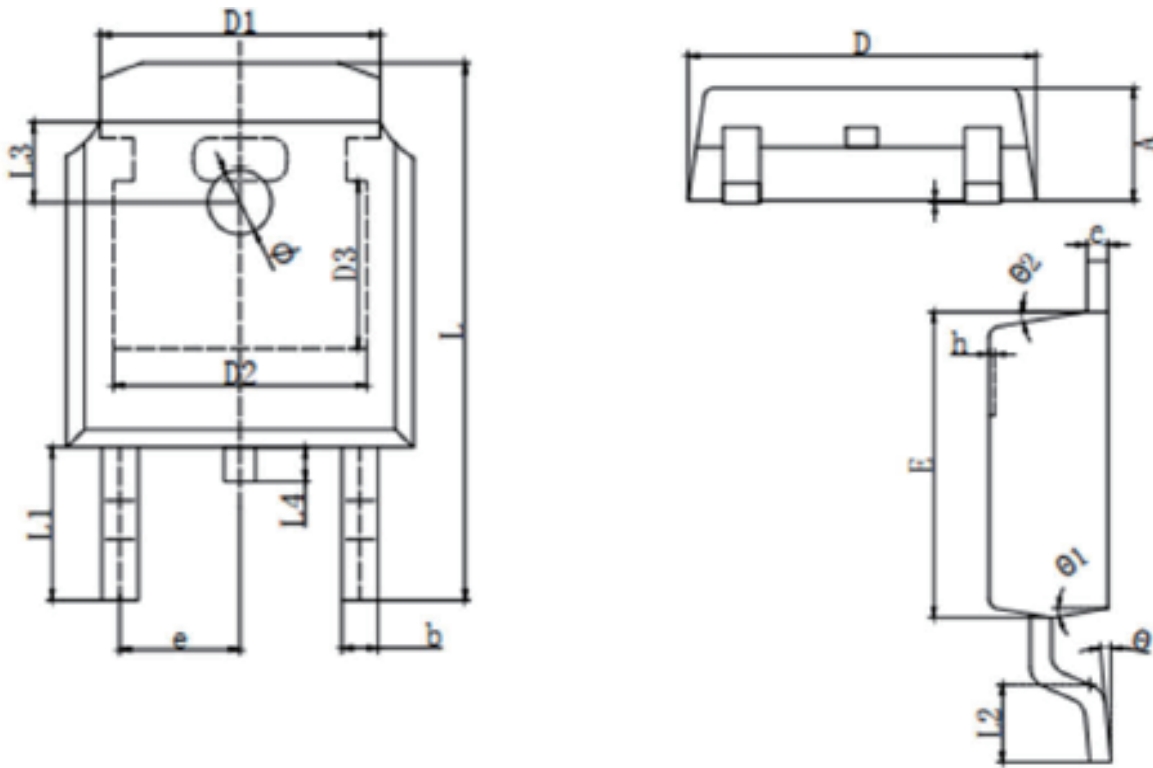

Figure 10: Unclamped Inductive Switching



TO-252 Package outline



SYMBOL	MILLIMETER		SYMBOL	MILLIMETER	
	MIN	MAX		MIN	MAX
A	2.200	2.400	h	0.000	0.200
A1	0.000	0.127	L	9.900	10.30
b	0.640	0.740	L1	2.888 REF	
c	0.460	0.580	L2	1.400	1.700
D	6.500	6.700	L3	1.600 REF	
D1	5.334 REF		L4	0.600	1.000
D2	4.926 REF		ϕ	1.100	1.300
D3	3.166 REF		θ	0°	8°
E	6.000	6.200	$\theta 1$	9° TYP2	
e	2.286 TYP		$\theta 2$	9° TYP	