

1

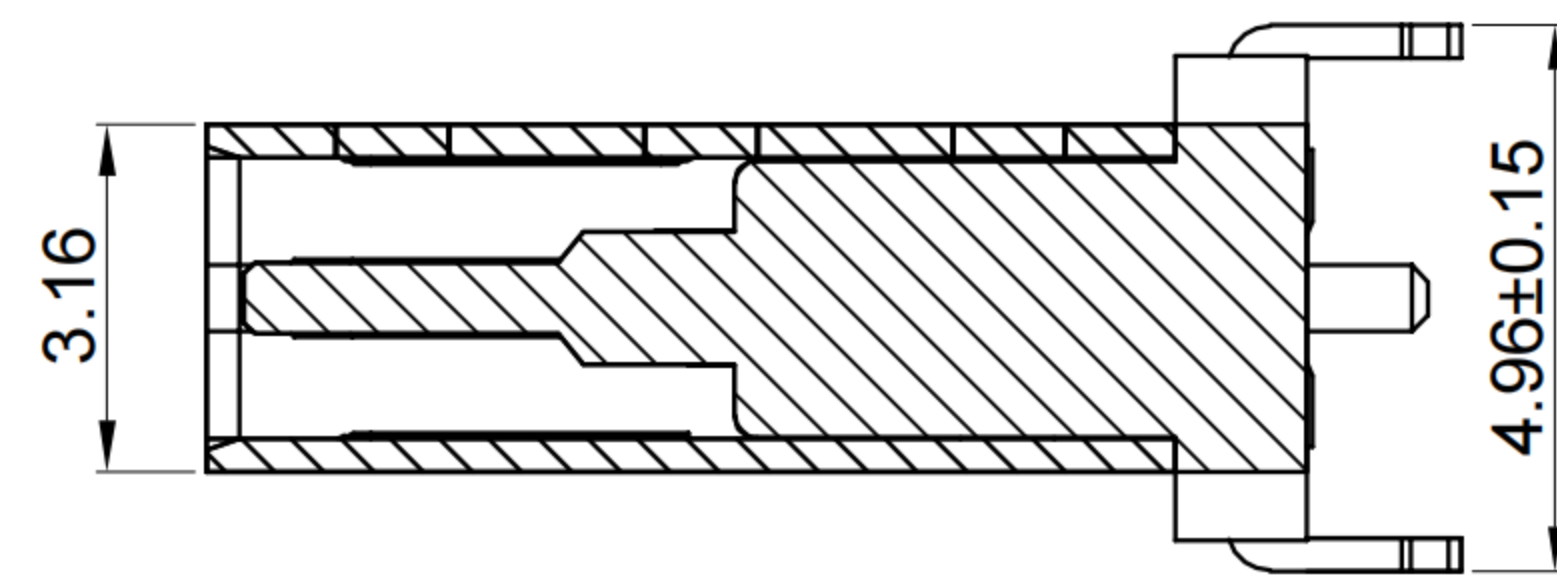

SECTION A-A

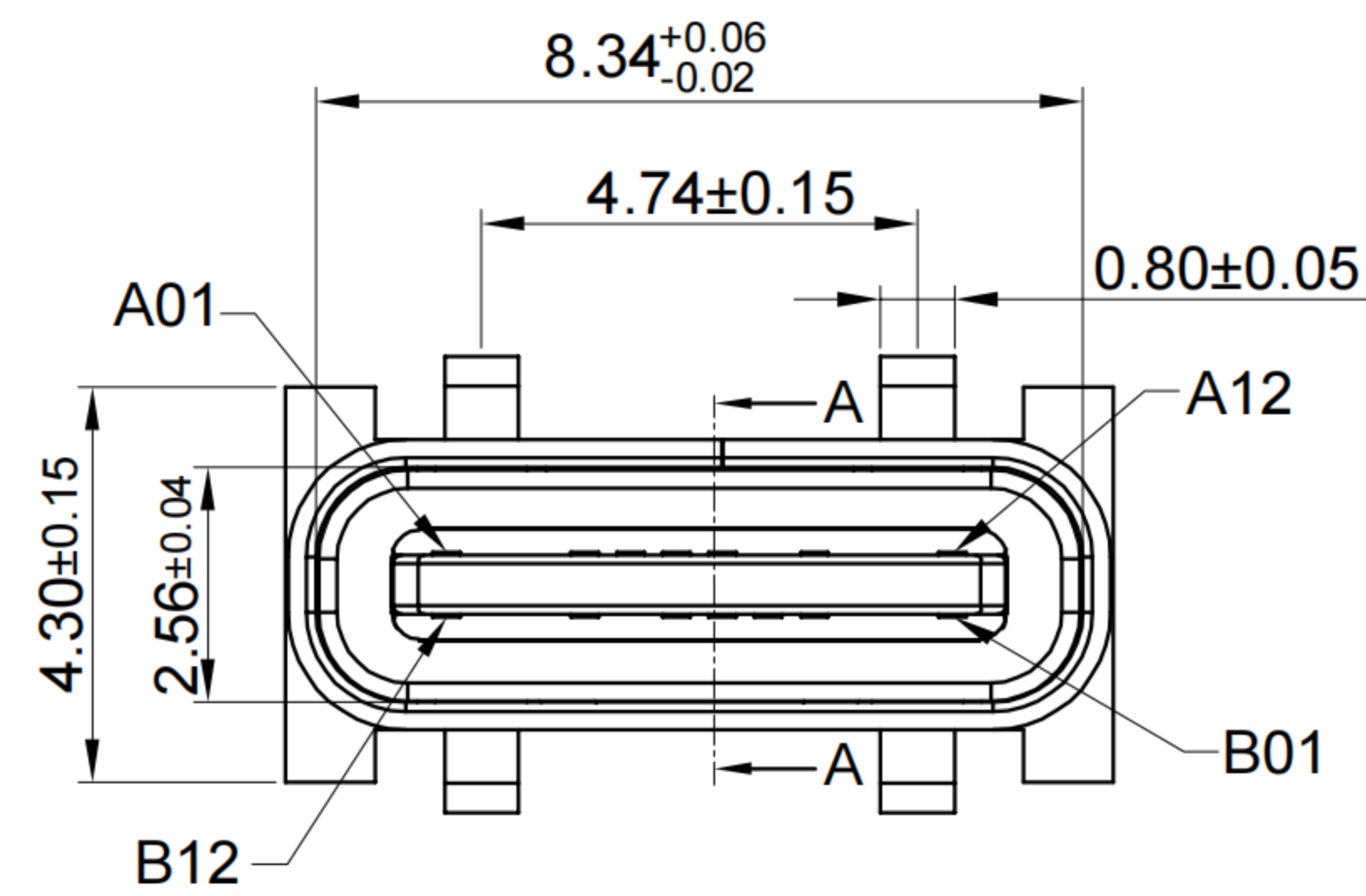
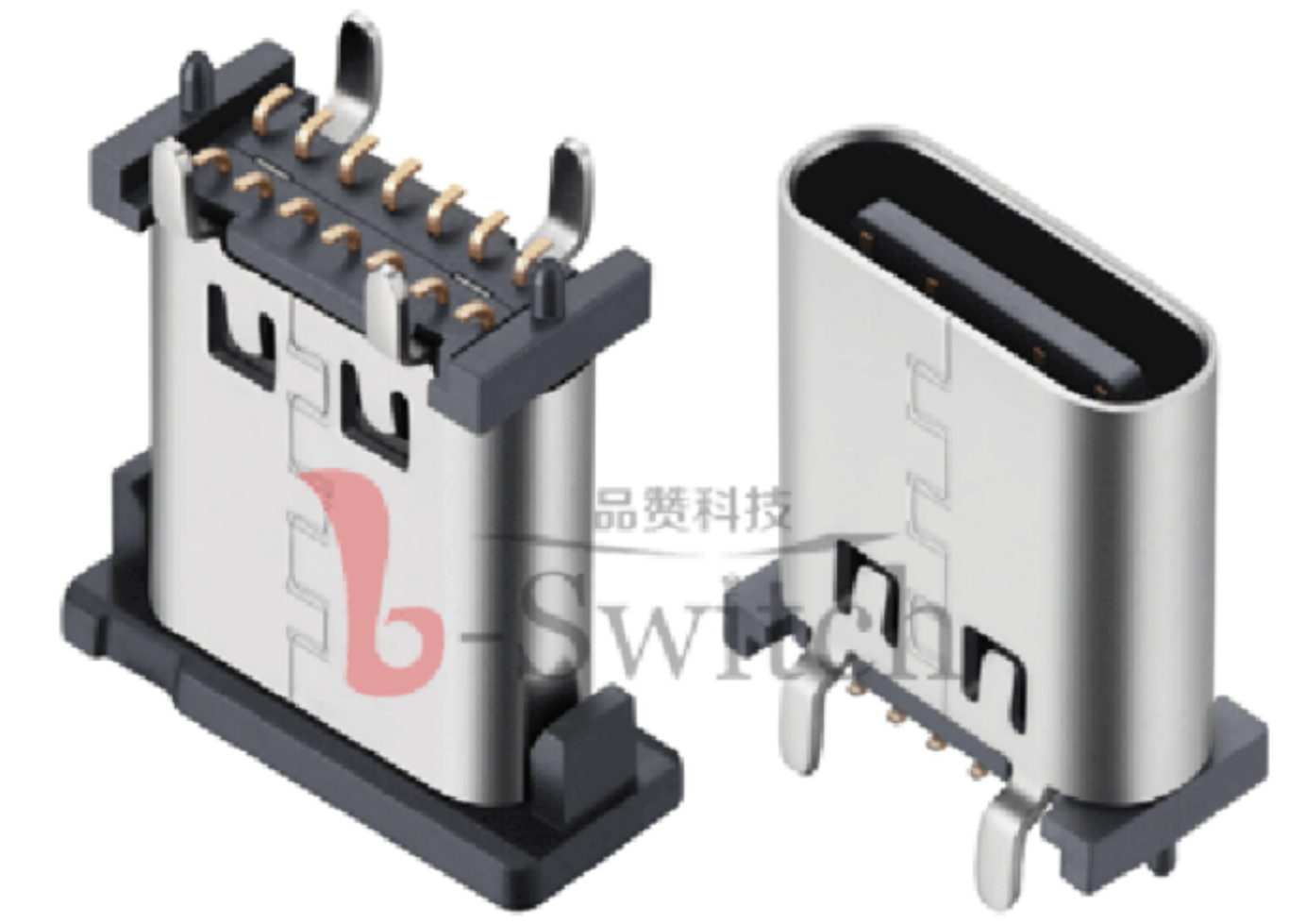
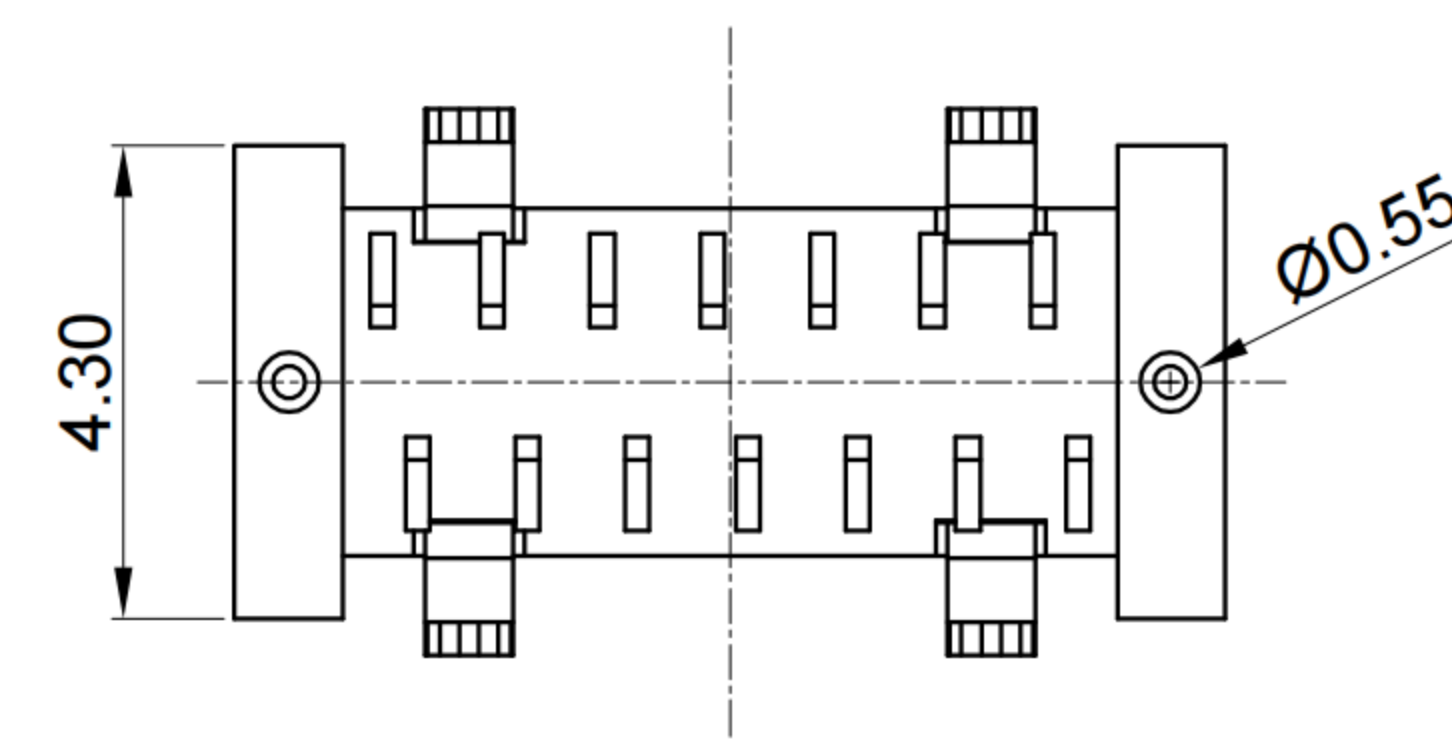

2

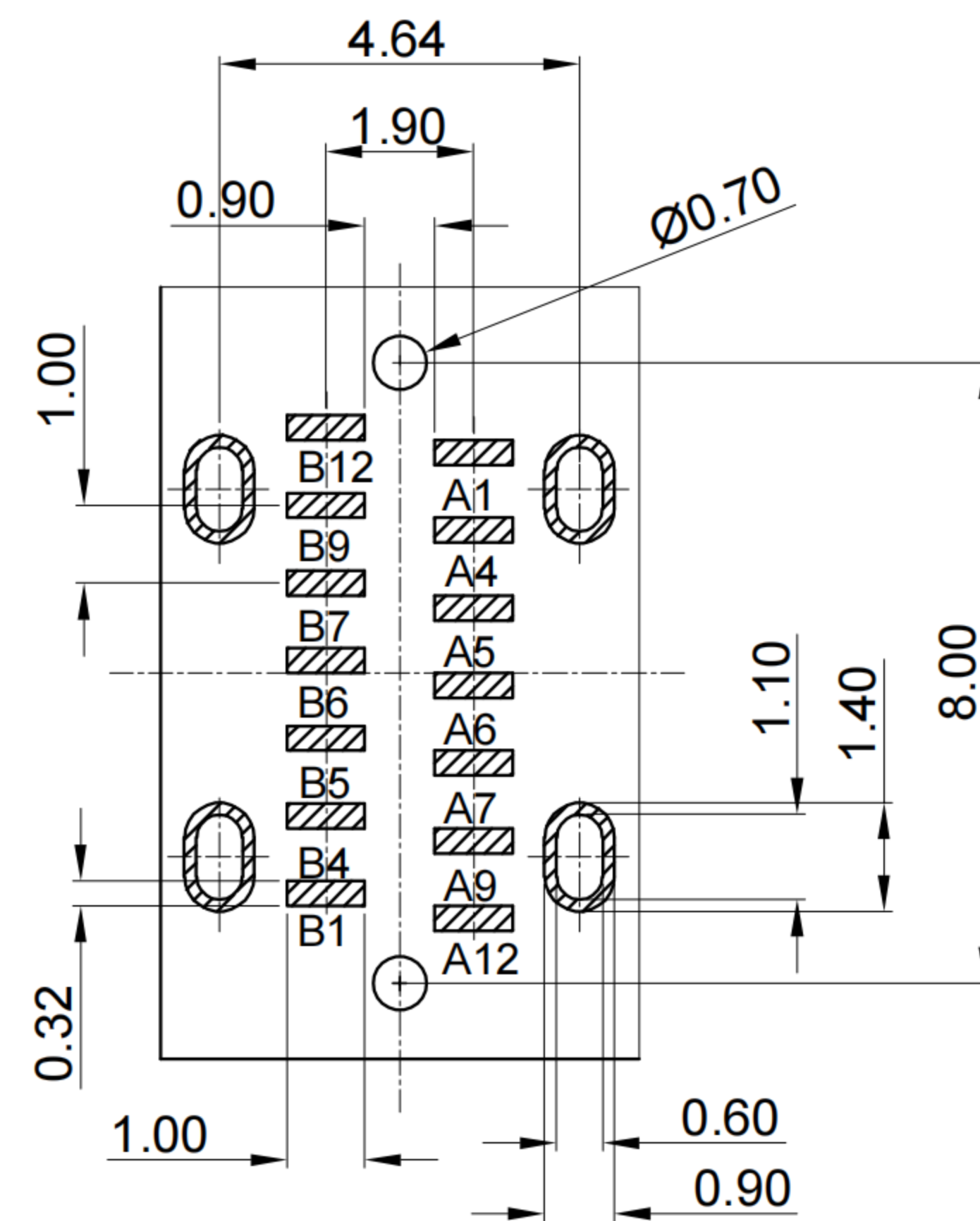
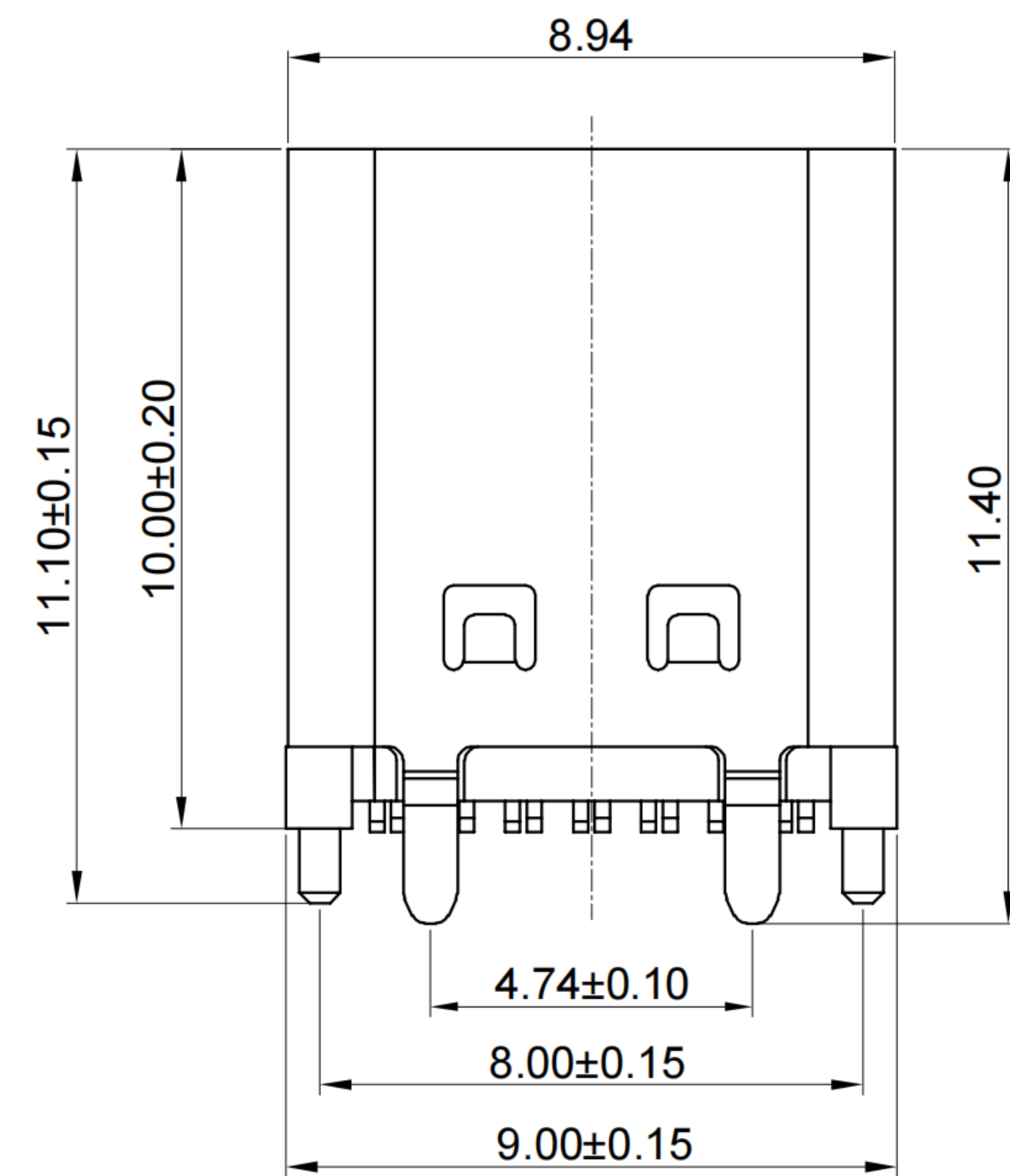

RECOMMENDED PCB LAYOUT
TOLERANCE: ±0.05

G-Switch USB-C Specification:

1. Current rating: 3A on Vbus/1.25A on Vconn/0.25A on other
Voltage rating: 24V AC
2. Dielectric Voltage: 100V AC/minute
3. Contact resistance: 40mΩ Max
4. Insulation resistance: 100MΩ Min
5. Temperature range: -55 °C ~ +85 °C
6. Mating force: 5N~20N
7. Unmating force: 8N~20N
8. Durability: 10,000 Cycles

A1	A2	A3	A4	A5	A6	A7	A8	A9	A10	A11	A12
GND			VBUS	CC1	D+	D-		VBUS			GND
First			First	Second	Second	Second		First			First
B12	B11	B10	B9	B8	B7	B6	B5	B4	B3	B2	B1
GND			VBUS		D-	D+	CC2	VBUS			GND
First			First		Second	Second	Second	First			First

5

1	SHELL	STAINLESS STEEL	NI PLATED
2	HOUSING	HIGH TEMPERATURE PLASTIC	BLACK UL 94 V-0
3	TERMINALS	COPPER ALLOY	Au PLATING ON CONTACT AREA
4	CAP	HIGH TEMPERATURE PLASTIC	BLACK UL 94 V-0
NO.	PARTS	MATERIAL	REMARKS

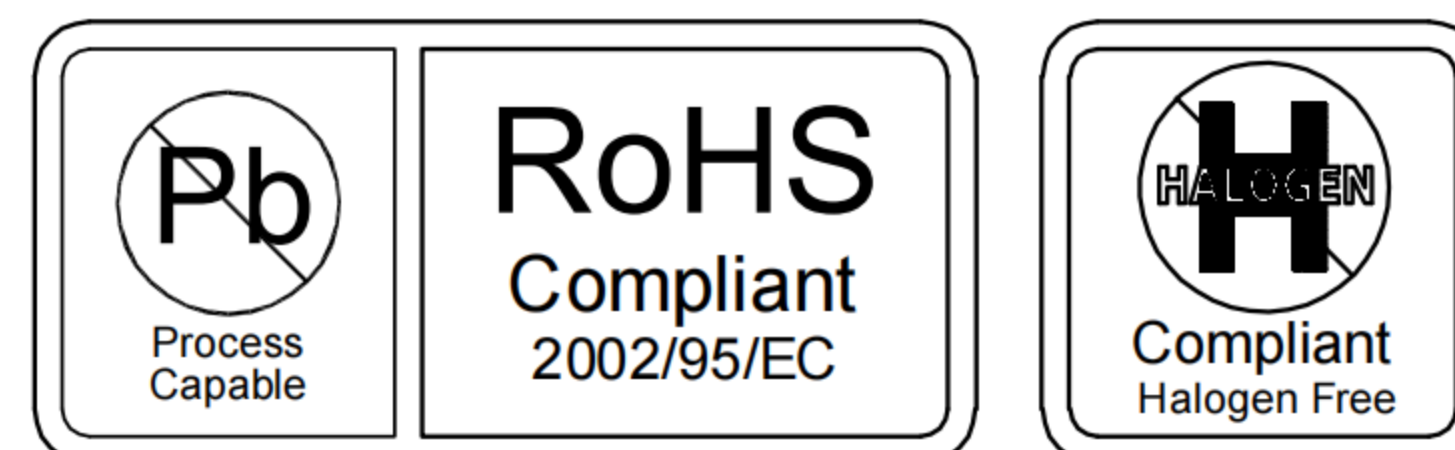

SCALE: 4:1	UNIT: mm	Title: Vertical Type-c 14P Female SMT L=10.0mm			
SIZE: A4		Molde Code: GT-USB-7090B			
Unless otherwise General Tolerance:		DRAWN	CHECKED	APPROVED	DATE
X.	±0.20	Xia	Chen	Chen	2022.11.21
X.x	±0.15				
X.xx	±0.10				
X.xxx	±0.05				
Angles	±3°				
		REV: A0	SHEET: 1/1		

