

## Features

- Adjustable output voltage: 2.5 to 36 V
- Sink current capability: 1 to 100 mA
- Typical output impedance: 0.22  $\Omega$
- 1% and 2% voltage precision
- Automotive temp. range - 40 °C to +125 °C

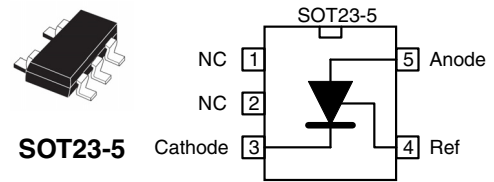

SOT23-5 pin connections (top view)

## Applications

- Power supply
- Industrial
- Automotive

## Description

The TL431AIDBVR are programmable shunt voltage references with guaranteed temperature stability over the entire operating temperature range. The device temperature range is extended for the automotive version from -40 °C up to +125 °C. The output voltage can be set to any value between 2.5 and 36 V with two external resistors. The TL431AIDBVR operate with a wide current range from 1 to 100 mA with a typical dynamic impedance of 0.22  $\Omega$ .

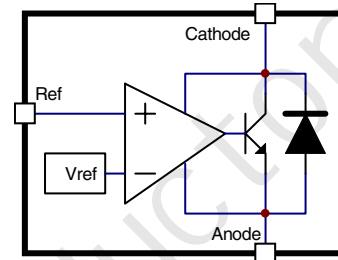

TL431AIDBVR block diagram

## Absolute maximum ratings and operating conditions

### Absolute maximum ratings

Symbol	Parameter	Value	Unit
$V_{KA}$	Cathode to anode voltage	37	V
$I_k$	Continuous cathode current range	-100 to +150	mA
$I_{ref}$	Reference input current range	-0.05 to +10	mA
$R_{thja}$	SOT23-5	157	°C/W
$R_{thjc}$	SOT23-5	67	°C/W
$T_{stg}$	Storage temperature range	-65 to +150	°C
$T_J$	Junction temperature	150	°C
ESD	TL431AIDBVR: HBM (human body model)	3000	V

## Operating conditions

Symbol	Parameter	Value	Unit
$V_{KA}$	Cathode to anode voltage	$V_{ref}$ to 36	V
$I_k$	Cathode current	1 to 100	mA
$T_{oper}$	TL431AIDBVR	-40 to +125	°C

## Electrical characteristics

$T_{amb} = 25^\circ\text{C}$  unless otherwise specified)

Symbol	Parameter	Min.	Typ.	Max.	Unit
$V_{ref}$	Reference input voltage $V_{KA} = V_{ref}$ , $I_k = 10\text{ mA}$ $T_{min} \leq T_{amb} \leq T_{max}$	2.47 2.44	2.495	2.52 2.55	V
$\Delta V_{ref}$	Reference input voltage deviation over temperature range <sup>(1)</sup> $V_{KA} = V_{ref}$ , $I_k = 10\text{ mA}$ , $T_{min} \leq T_{amb} \leq T_{max}$		7	30	mV
$\frac{\Delta V_{ref}}{\Delta V_{ka}}$	Ratio of change in reference input voltage to change in cathode to anode voltage $I_k = 10\text{ mA}$ , $\Delta V_{KA} = 10\text{ V to } V_{ref}$ $I_k = 10\text{ mA}$ , $\Delta V_{KA} = 36\text{ V to } 10\text{ V}$	-2.7 -2	-1.4 -1		mV/V
$I_{ref}$	Reference input current $I_k = 10\text{ mA}$ , $R1 = 10\text{ k}\Omega$ , $R2 = \infty$ $T_{min} \leq T_{amb} \leq T_{max}$		1.8	4 6.5	$\mu\text{A}$
$\Delta I_{ref}$	Reference input current deviation over temperature range $I_k = 10\text{ mA}$ , $R1 = 10\text{ k}\Omega$ , $R2 = \infty$ , $T_{min} \leq T_{amb} \leq T_{max}$		0.8	1.2	$\mu\text{A}$
$I_{min}$	Minimum cathode current for regulation $V_{KA} = V_{ref}$		0.5	0.6	mA
$I_{off}$	Off-state cathode current $T_{min} \leq T_{amb} \leq T_{max}$		2.6	1000 3000	nA
$ ZKA $	Dynamic impedance <sup>(2)</sup> $V_{KA} = V_{ref}$ , $\Delta I_k = 1\text{ to } 100\text{ mA}$ , $F \leq 1\text{ kHz}$		0.22	0.5	$\Omega$

The dynamic impedance is defined as  $|ZKA| = \frac{\Delta V_{KA}}{\Delta I_k}$

### Reference input voltage deviation over temperature range

$\Delta V_{ref}$  is defined as the difference between the maximum and minimum values obtained over the full temperature range.

$$\Delta V_{ref} = V_{ref\ max} - V_{ref\ min}$$

### Reference input voltage deviation over temperature range

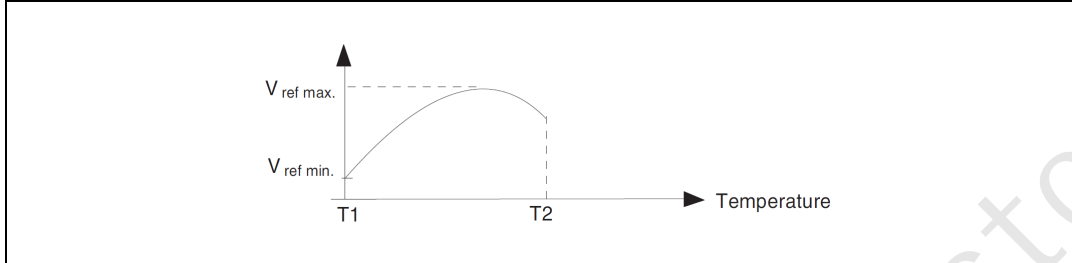

### Test circuit for $V_{KA} = V_{ref}$

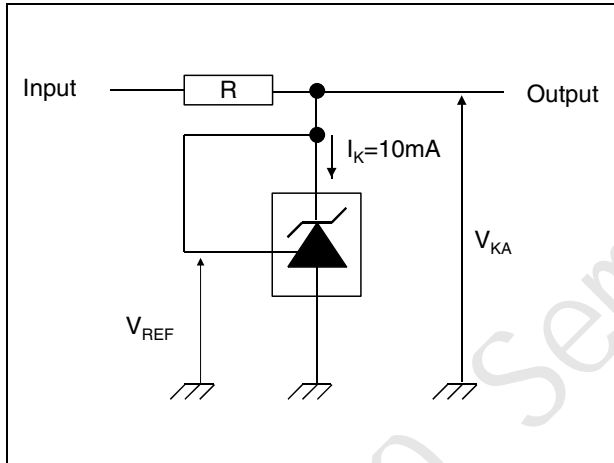

### Test circuit for programming mode

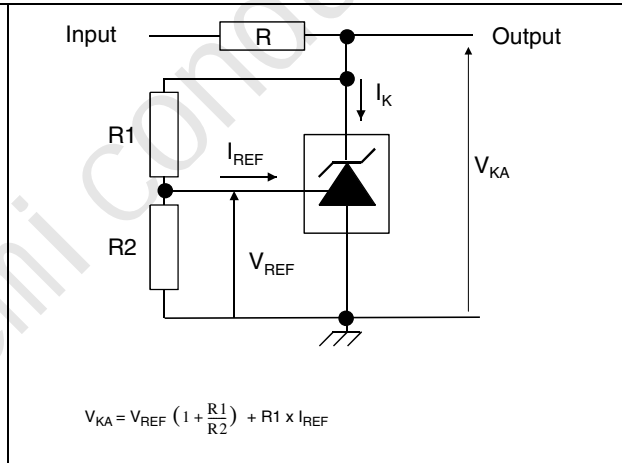

### Test circuit for $I_{off}$

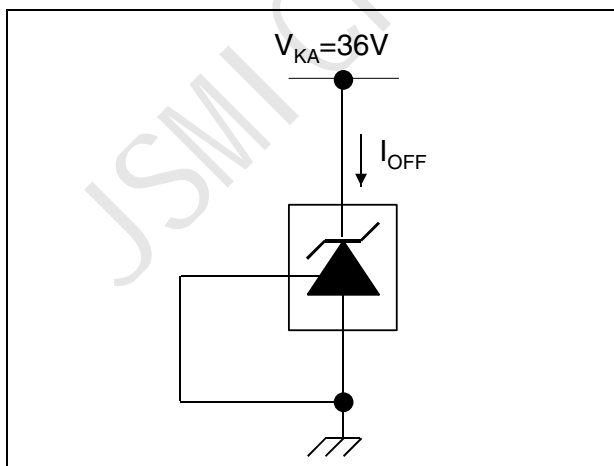

### Test circuit for phase margin and voltage gain

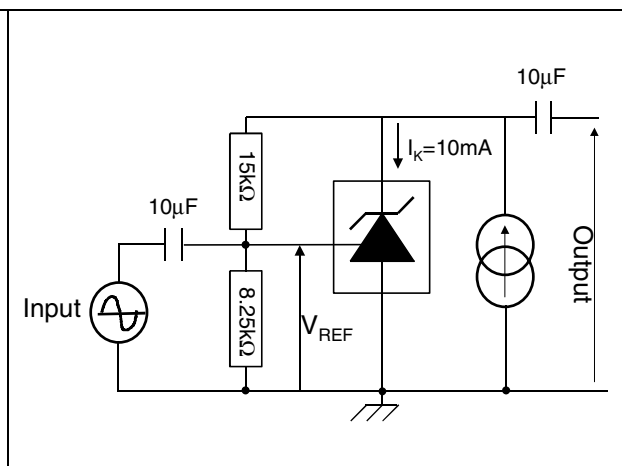

**Test circuit for response time**

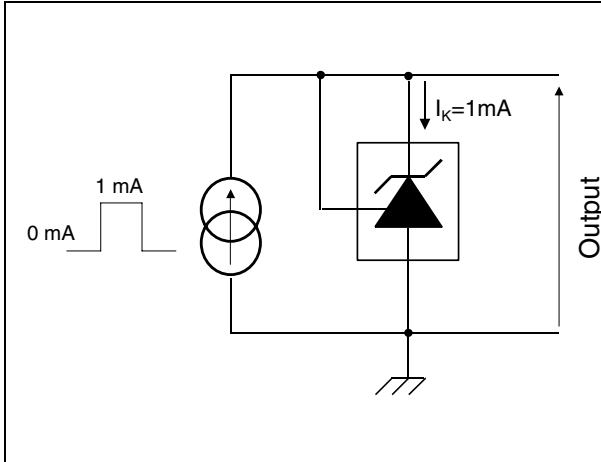

**Reference voltage vs. temperature**

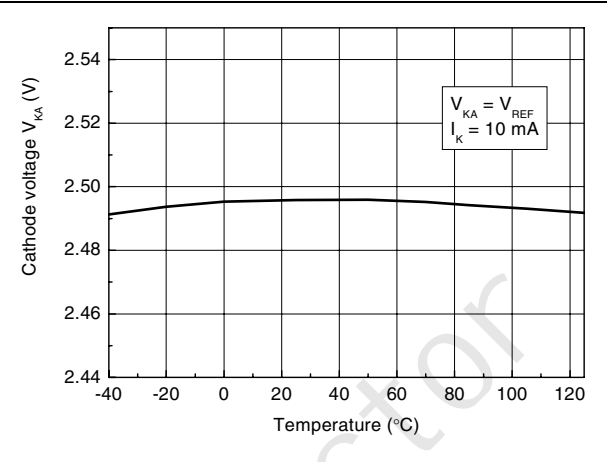

**Reference voltage vs. cathode current**

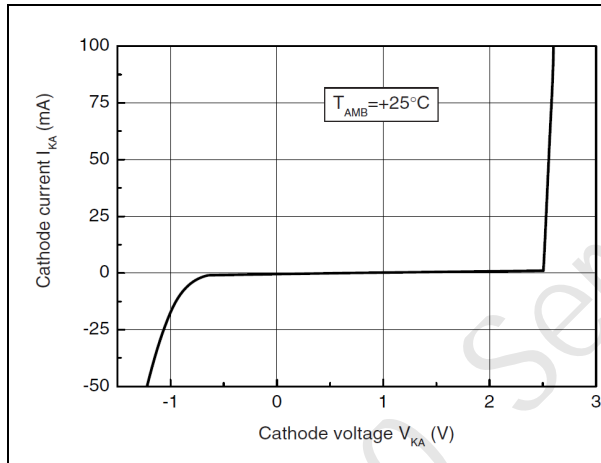

**Zoom on reference voltage vs. cathode current**

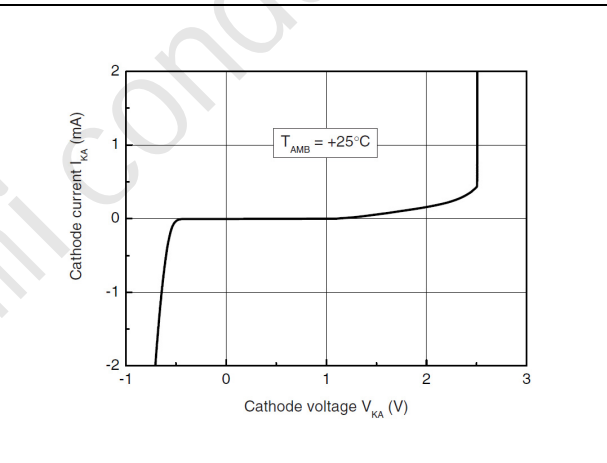

**Reference current vs. temperature**

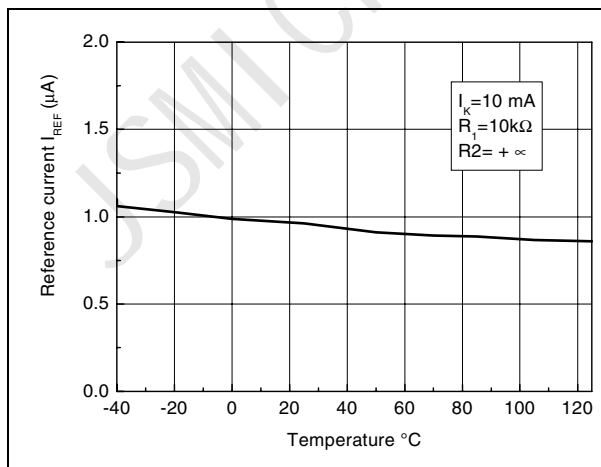

**Off-state cathode current vs. temperature**

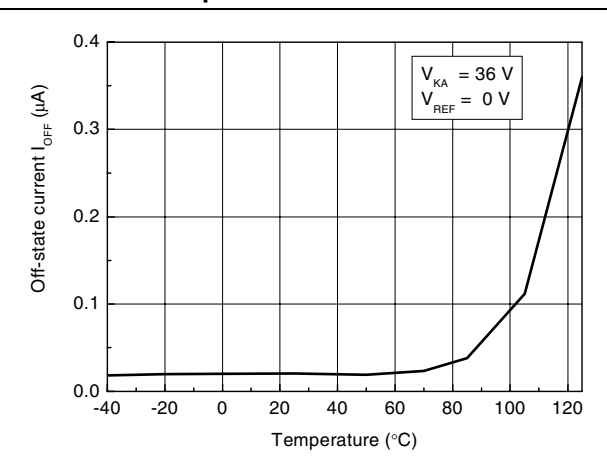

Ratio of change in  $V_{REF}$  to change in  $V_{KA}$  vs. temperature

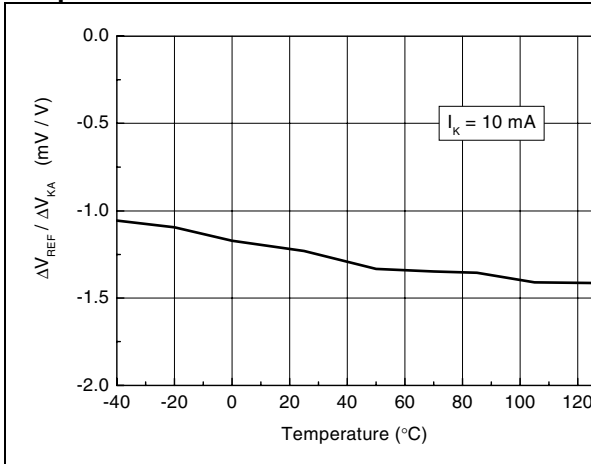

Static impedance  $R_{KA}$  vs. temperature

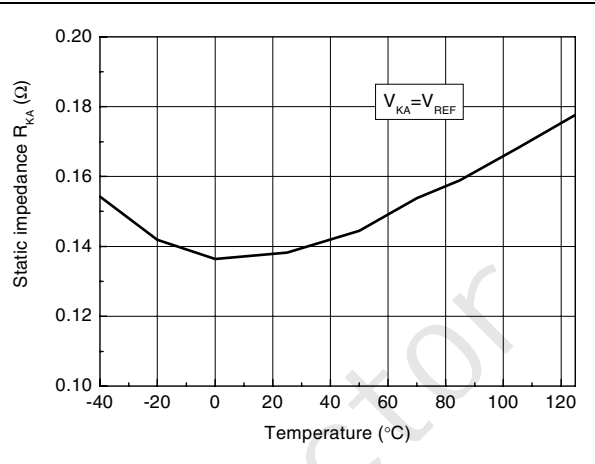

Minimum operating current vs. temperature

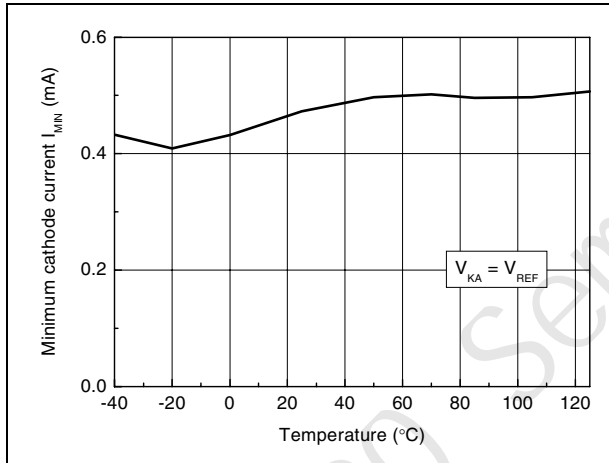

Gain and phase vs. frequency

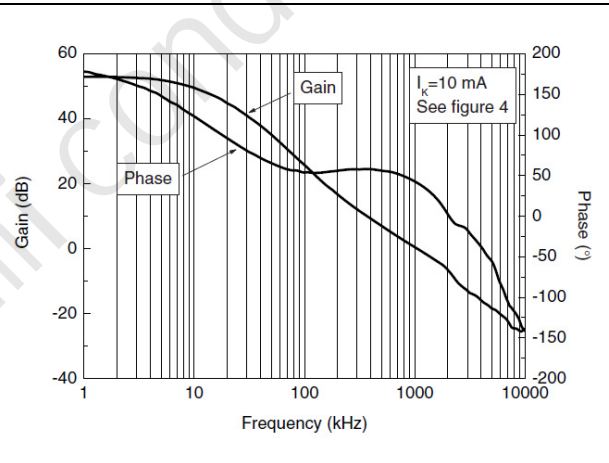

Stability behavior with capacitive loads

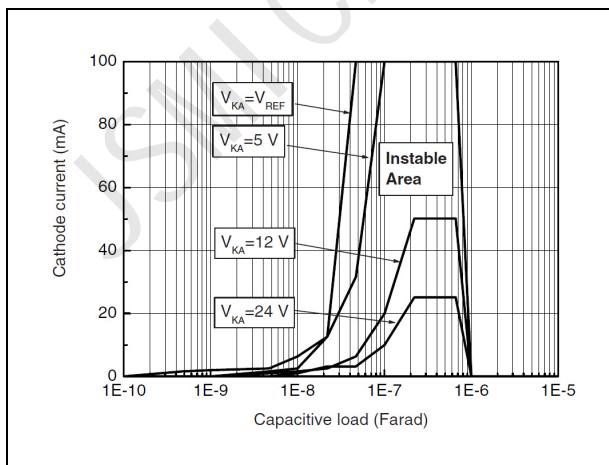

Pulse response for  $I_K = 1$  mA

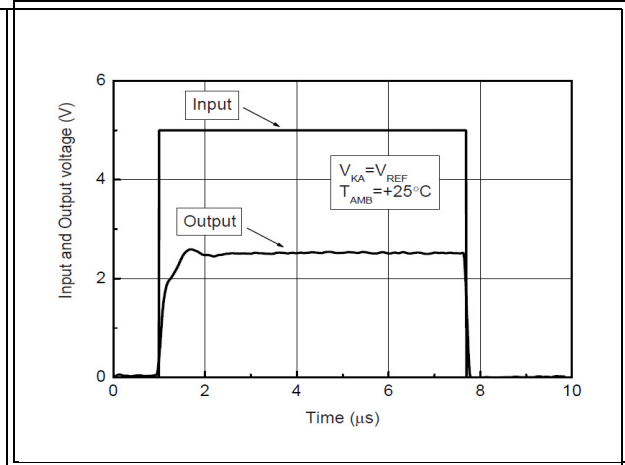

## SOT23-5 package information

SOT23-5 package mechanical drawing

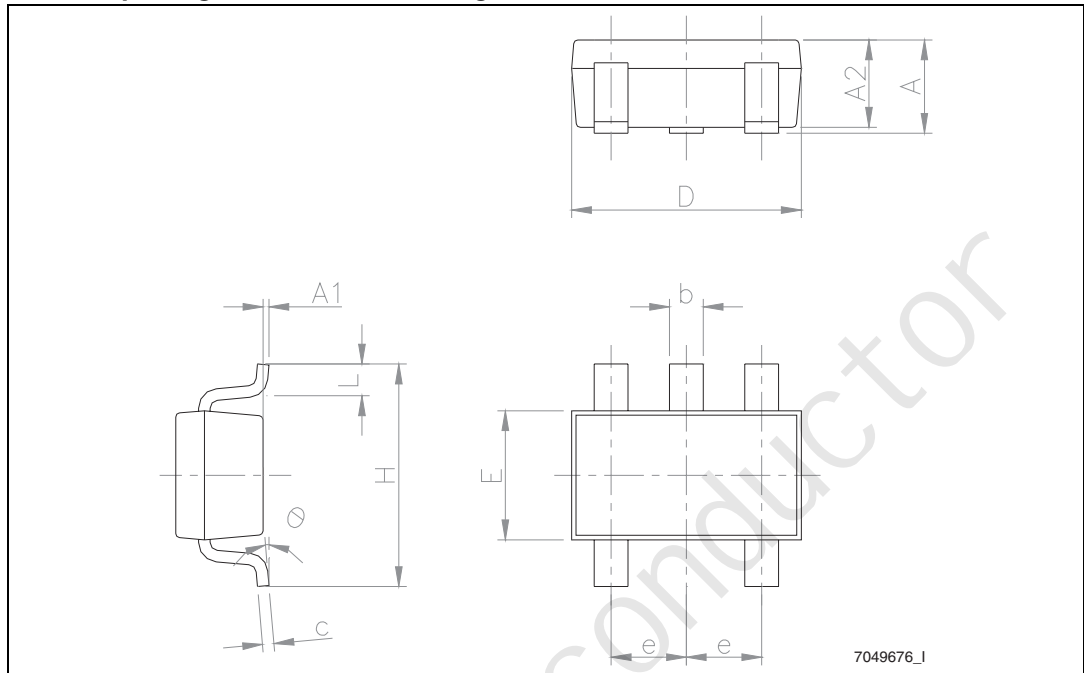

SOT23-5 package mechanical data

Ref.	Dimensions					
	Millimeters			Inches		
	Min.	Typ.	Max.	Min.	Typ.	Max.
A	0.90		1.45	0.035		0.057
A1			0.15			0.006
A2	0.90		1.30	0.035		0.051
b	0.35		0.50	0.014		0.020
c	0.09		0.20	0.004		0.008
D	2.80		3.05	0.110		0.120
E	1.50		1.75	0.059		0.069
e		0.95			0.037	
H	2.60		3.00	0.102		0.118
L	0.10		0.60	0.004		0.024
$\theta$	0 degrees		10 degrees			