



REV.	ECN NO.	REVISED	DATE

NOTE:

- 1.MATERIAL:
 a.HOUSING:ABS BLACK
 b.CONTACT:304 Stainless Steel Spring Temper
 (SURFACE PLATING: Ni-PLATING)
 SEE ORDERING INFORMATION

- 2.ELECTRIC:
 a.CONTACT RESISTANCE: 100 MILLIOHMS MAX
 b.INSULATION RESISTANCE: 100 MEGA OHMS MIN
 c.DIELECTNIC VOLTAGE: 500V AC ONE MINUTE
 d.OPERATING TEMPERATURE: -25° C~ +85° C

ORDERING INFORMATION

BH-21700-A5BJ001

电池盒
 电池型号
 DIP 90° TYPE

PLATING:
 A-Au1U"
 J-Ni-PLATING
 K-Sn-PLATING

MATERIAL:
 1A-PBT BLACK
 1B-PA66 BLACK
 2A-PPA BROWN
 2B-PPA BLACK
 3A-PPS BROWN
 3B-PPS BLACK
 4A-LCP WHITE
 4B-LCP BLACK
 5B-NYLON RESIN BLACK

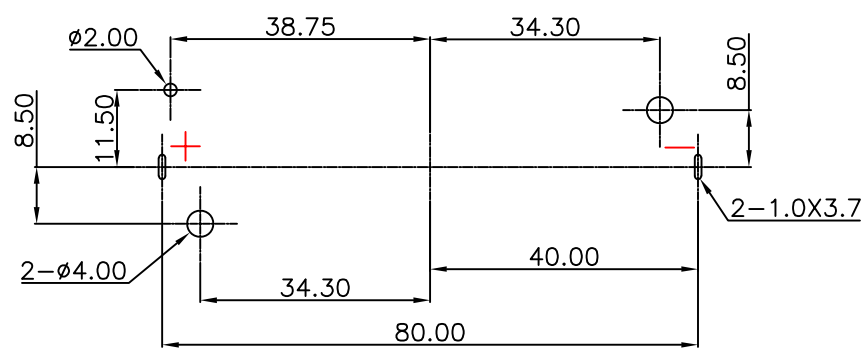
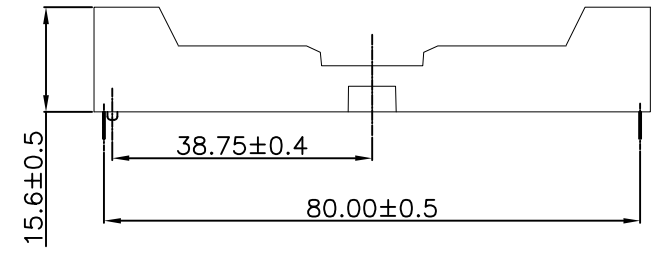
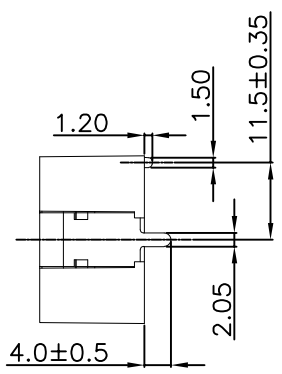
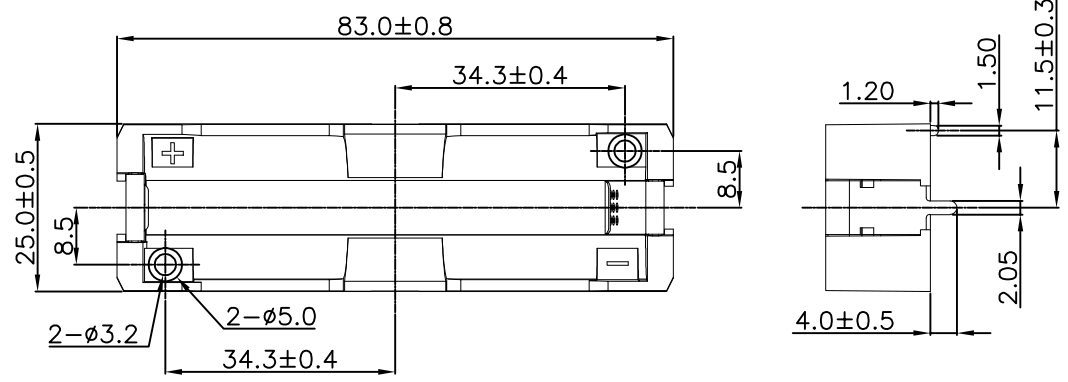

PCB Layout Diagram
TOP View

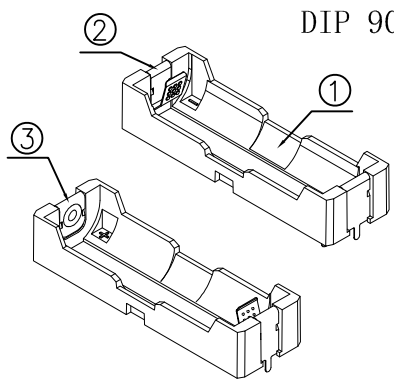

工程部
2023-08-14
H. WANG

3	TERMINAL(+)	1	304 Stainless Steel, T=0.3MM	Ni-Plating
2	TERMINAL(-)	1	304 Stainless Steel, T=0.3MM	Ni-Plating
1	HOUSING	1	NYLON RESIN	BLACK
NO.	PART NAME	Q'TY	MATERIAL	PLATING & COLOR

UNLESS OTHERWISE SPECIFIED TOLERANCES		MYOUNG 美用 www.meiyangdz.com	
DECIMALS: X :±0.30 X.X :±0.25 X.XX :±0.20 X.XXX :±0.10	ANGLES: X :±1° X.X :±0.5°	DSND YangFeng	DATE 2023-08-14
WEIGHT:		CHKD ZhouRuicai	DATE 2023-08-14
SHEET 1 OF 1		APVD XueShunyong	DATE 2023-08-14
SCALE:		SIZE: A4	VIEW:
UNIT: mm		REV.: A/0	OBJECT: MY
TITLE:		TITLE: 电池盒BH-21700-1J Ni DIP	
PART NO.:		PART NO.: BH-21700-A5BJ001	
DRAW NO.:		DRAW NO.:WD-CP-0332	