

HAOYU

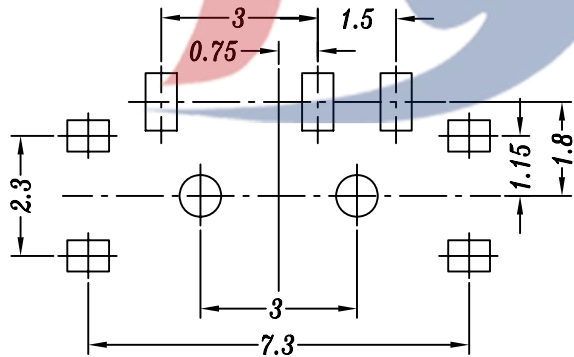

P.C.B LAYOUT

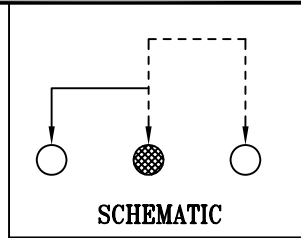
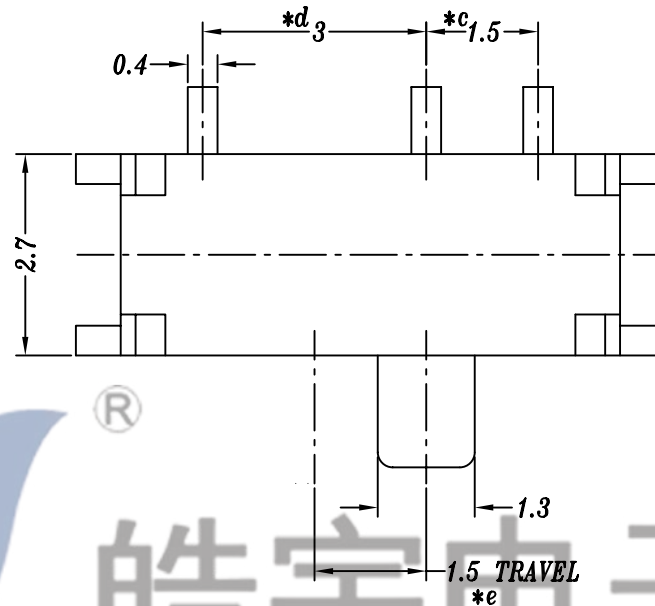
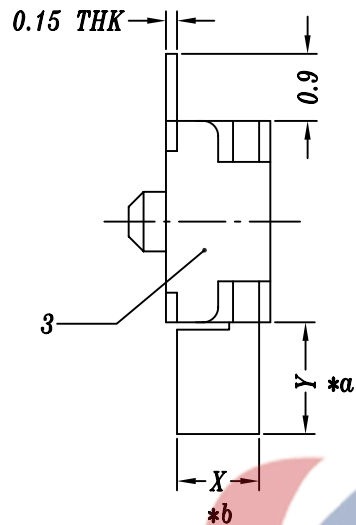
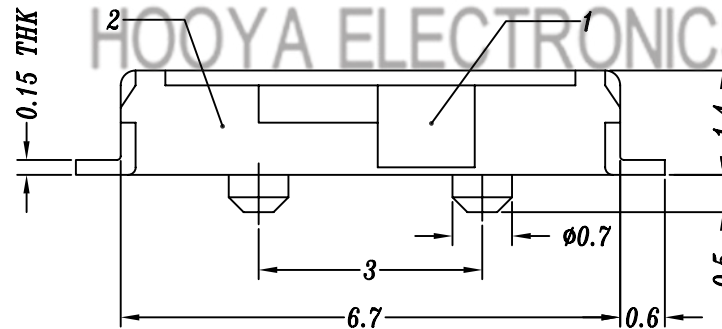

SPECIFICATION

1. Rating: DC 12V 0.3A
2. Travel: 1.5 mm
3. Function: 1P2T
4. Contact Resistance:  $\leq 70\text{m}\Omega\text{MAX}$
5. Operating Force:  $200\pm 80\text{gf}$
6. Life test: 10,000 cycles

电话 : 0769-82320511-867

MODEL NO:	KNOB X
MK12C02EA	0.4
MK12C02EB	1.1

KNOB Y = 1.5, 2.0, 2.3, 2.5mm

				TOLERANCE UNLESS SPECIFIED								
				UP TO 5mm: $\pm 0.1$	ANGULAR	1	2017.4.13	初版			PWJ	
				ABOVE 5mm: $\pm 0.2$	$\pm 1^\circ$	NO	DATE	REVISIONS		BY	APPD	
5	MK12C02 CONTACT	BERYLLIUM/PBS	1	Ag PLATED	TITLE: MINI SLIDE SWITCH			UNIT : MM	ROHS COMPLIANT	DWN		
4	MK12C02 SPRING PLATE	0.15mm SUS	1	NATURAL	MODEL: MK-12C02G1.5-W			SCALE: 10:1	CHK'D			
3	MK12C02 COVER	0.15mm SUS	1	Ag PLATED	<b>HAOYU(HONGKONG)LIMITED</b> 皓宇(香港)有限公司						APPD	
2	MK12C02 CASE	PA6T/LCP/4# BRASS STRIP	1	BLACK/Ag PLATED							PRO.AGL:	
1	MK12C02 KNOB	PA6T/PA66/LCP	1									
NO.	PART NAME	MATERIAL	QTY	FINISHING								