

Features

- For general AF applications
- High collector current
- High current gain
- Low collector-emitter saturation voltage
- Complementary type: GSBCP69 (PNP)

1. BASE
 2. COLLECTOR
 3. EMITTER

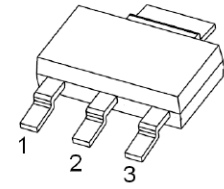

SOT-223

Absolute Maximum Ratings ($T_A=25^\circ\text{C}$ unless otherwise noted)

Parameter	Symbol	Value	Unit
Collector-Base Voltage	V_{CB0}	32	V
Collector-Emitter Voltage	V_{CEO}	20	V
Emitter-Base Voltage	V_{EBO}	5	V
Collector Current – Continuous	I_c	1	A
Collector Power Dissipation	P_C	1	W
Thermal Resistance Junction to Ambient	$R_{\theta JA}$	94	$^\circ\text{C/W}$
Storage Temperature Range	T_{STG}	-65 to +150	$^\circ\text{C}$

Electrical Characteristics ($T_A=25^\circ\text{C}$ unless otherwise noted)

Parameter	Symbol	Test Conditions	Min	Typ	Max	Unit
Collector-Base Breakdown Voltage	$V_{(BR)CBO}$	$I_c=100\mu\text{A}, I_E=0$	32	-	-	V
Collector-Emitter Breakdown Voltage	$V_{(BR)CEO}$	$I_c=1\text{mA}, I_B=0$	20	-	-	V
Emitter-Base Breakdown Voltage	$V_{(BR)EBO}$	$I_E=100\mu\text{A}, I_c=0$	5	-	-	V
Collector Cut-Off Current	I_{CBO}	$V_{CB}=25\text{V}, I_E=0$	-	-	0.1	μA
Emitter Cut-Off Current	I_{EBO}	$V_{EB}=5\text{V}, I_c=0$	-	-	0.1	μA
DC Current Gain	$h_{FE(1)}$	$V_{CE}=1\text{V}, I_c=500\text{mA}$	85	-	375	-
	$h_{FE(2)}$	$V_{CE}=1\text{V}, I_c=1\text{A}$	60	-	-	-
	$h_{FE(3)}$	$V_{CE}=10\text{V}, I_c=5\text{mA}$	50	-	-	-
Collector-Emitter Saturation Voltage	$V_{CE(sat)}$	$I_c=1\text{A}, I_B=100\text{mA}$	-	-	0.5	V
Base-Emitter Voltage	V_{BE1}	$V_{CE}=10\text{V}, I_c=5\text{mA}$	-	-	0.68	V
	V_{BE2}	$V_{CE}=1\text{V}, I_c=1\text{A}$	-	-	1	V
Transition Frequency	f_T	$V_{CE}=5\text{V}, I_c=10\text{mA}, f=100\text{MHz}$	40	-	-	MHz
Collector Output Capacitance	C_{ob}	$V_{CB}=5\text{V}, I_E=0, f=1\text{MHz}$	-	38	-	pF

Classification of $h_{FE(1)}$

Rank	GSBCP68-10	GSBCP68-16	GSBCP68-25
Range	85-160	100-250	160-375

Package Outline Dimensions (SOT-223)

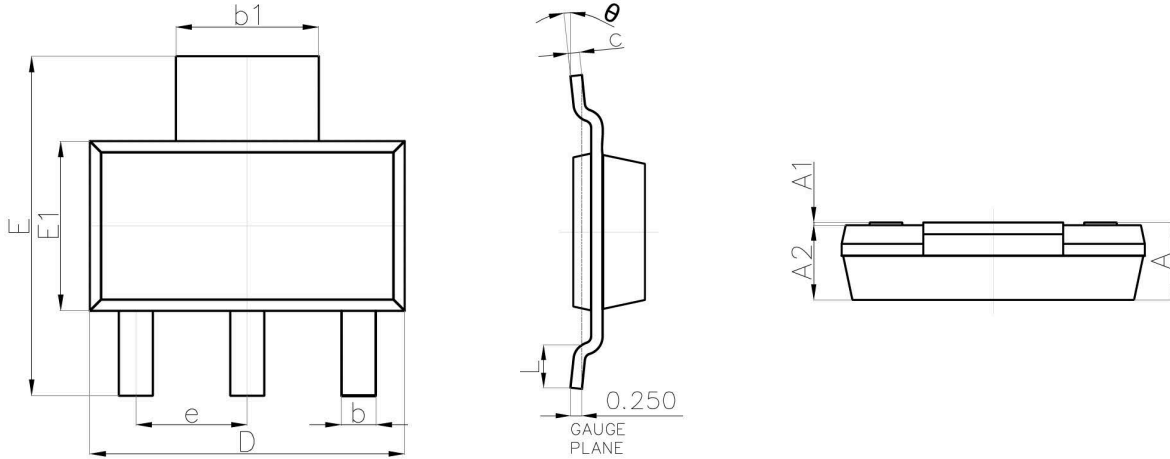

Symbol	Dimensions In Millimeters		Dimensions In Inches	
	Min.	Max.	Min.	Max.
A	-	1.800	-	0.071
A1	0.020	0.100	0.001	0.004
A2	1.500	1.700	0.059	0.067
b	0.660	0.840	0.026	0.033
b1	2.900	3.100	0.114	0.122
c	0.230	0.350	0.009	0.014
D	6.300	6.700	0.248	0.264
E	6.700	7.300	0.264	0.287
E1	3.300	3.700	0.130	0.146
e	2.300 (BSC)		0.091 (BSC)	
L	0.750	-	0.030	-
θ	0°	10°	0°	10°

Recommended Pad Layout

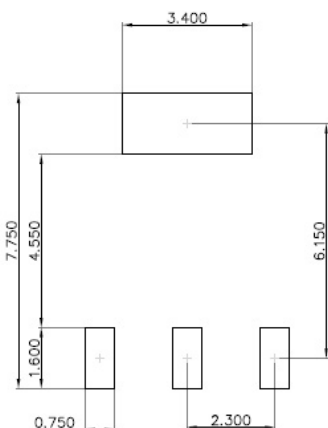

- Note:**
1. Controlling dimension: in millimeters.
 2. General tolerance: ± 0.050 mm.
 3. The pad layout is for reference purposes only.