

Main Product Characteristics

BV_{DSS}	-20V
$R_{DS(ON)}$	17m Ω (Typ.@ $V_{GS}=-4.5V$)
	24m Ω (Typ.@ $V_{GS}=-2.5V$)
	33m Ω (Typ.@ $V_{GS}=-1.8V$)
I_D	-5A

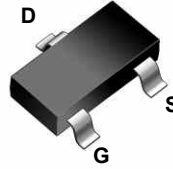

SOT-23-3L

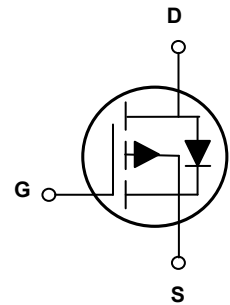

Schematic Diagram

Features and Benefits

- Advanced MOSFET process technology
- Ideal for high efficiency switched mode power supplies
- Low on-resistance with low gate charge
- Fast switching and reverse body recovery



Applications

- Switch switching
- Power management in portable/desktop PCs

Description

The GSFC02A05 utilizes the latest techniques to achieve high cell density and low on-resistance. These features make this device extremely efficient and reliable for use in high efficiency switch mode power supplies and a wide variety of other applications.

Absolute Maximum Ratings ($T_C=25^\circ C$ unless otherwise specified)

Parameter	Symbol	Max.	Unit
Drain-Source Voltage ($V_{GS}=0V$)	V_{DS}	-20	V
Gate-Source Voltage ($V_{GS}=0V$, Static)	V_{GS}	± 12	V
Drain Current-Continuous ($T_C=25^\circ C$)	I_D	-5	A
Drain Current-Continuous ($T_C=100^\circ C$)		-3.5	
Drain Current-Pulsed	I_{DM}	-20	A
Maximum Power Dissipation ($T_C=25^\circ C$)	P_D	1.6	W
Maximum Power Dissipation ($T_C=100^\circ C$)		1.0	
Thermal Resistance, Junction-to-Case	$R_{\theta JC}$	78	$^\circ C/W$
Thermal Resistance, Junction-to-Ambient	$R_{\theta JA}$	100	$^\circ C/W$
Operating Junction Temperature Range	T_J	-55 To +150	$^\circ C$
Storage Temperature Range	T_{STG}	-55 To +150	$^\circ C$

Electrical Characteristics

Parameter	Symbol	Conditions	Min.	Typ.	Max.	Unit
On/Off Characteristics						
Drain-Source Breakdown Voltage	BV_{DSS}	$V_{GS}=0V, I_D=-250\mu A$	-20	-	-	V
Drain-Source Leakage Current	I_{DSS}	$V_{DS}=-16V, V_{GS}=0V$ $T_J=25^\circ C$	-	-	-1	μA
Gate-Source Leakage Current	I_{GSS}	$V_{GS}=\pm 12V, V_{DS}=0V$	-	-	± 100	nA
Static Drain-Source On-Resistance	$R_{DS(on)}$	$V_{GS}=-4.5V, I_D=-5A$	-	17	22	m Ω
		$V_{GS}=-2.5V, I_D=-5A$	-	24	30	
		$V_{GS}=-1.8V, I_D=-5A$	-	33	38	
Gate Threshold Voltage	$V_{GS(th)}$	$V_{GS}=V_{DS}, I_D=-250\mu A$	-0.4	-0.7	-1	V
Dynamic and Switching Characteristics						
Total Gate Charge	Q_g	$V_{DS}=-10V, I_D=-10A,$ $V_{GS}=-4.5V$	-	24	-	nC
Gate-Source Charge	Q_{gs}		-	5.4	-	
Gate-Drain Charge	Q_{gd}		-	6	-	
Turn-One Delay Time	$t_{d(on)}$	$V_{DS}=-10V, R_L=1\Omega,$ $V_{GS}=-4.5V, R_G=3.3\Omega$	-	8	-	nS
Rise Time	t_r		-	40	-	
Turn-off Delay Time	$t_{d(off)}$		-	94	-	
Fall Time	t_f		-	70	-	
Input Capacitance	C_{iss}	$V_{DS}=-10V, V_{GS}=0V,$ $F=1MHz$	-	1930	-	pF
Output Capacitance	C_{oss}		-	243	-	
Reverse Transfer Capacitance	C_{rss}		-	234	-	
Gate Resistance	R_g	$F=1MHz$	-	4.4	-	Ω
Drain-Source Diode Characteristics and Maximum Ratings						
Diode Forward Voltage	V_{SD}	$V_{GS}=0V, I_{SD}=-1A$	-	-0.71	-1	V
Reverse Recovery Time	t_{rr}	$V_{GS}=0V, I_{SD}=-10A$	-	12	-	nS
Reverse Recovery Charge	Q_{rr}	$di/dt=100A/\mu s$	-	5	-	nC

Typical Electrical and Thermal Characteristic Curves

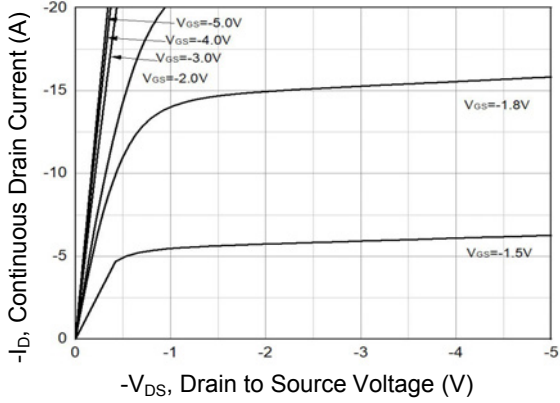

Figure 1. Typical Output Characteristics

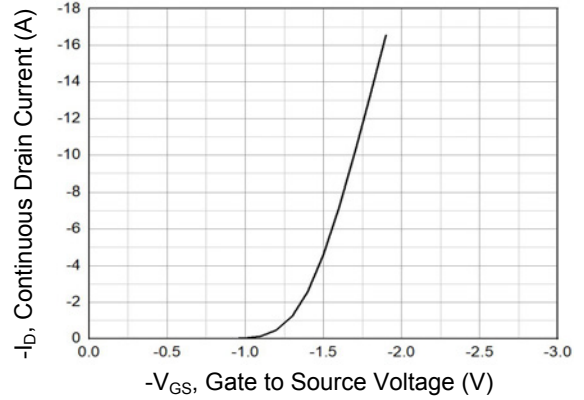

Figure 2. Transfer Characteristics

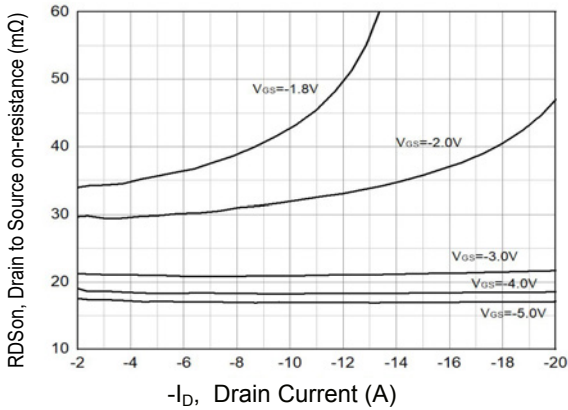

Figure 3. $R_{DS(on)}$ vs. I_D and Gate Voltage

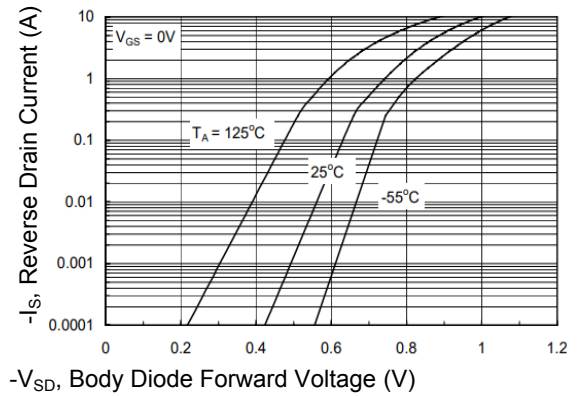

Figure 4. Body-Diode Characteristics

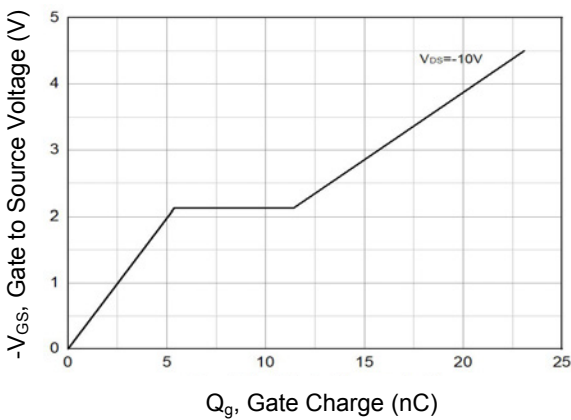

Figure 5. Gate Charge Characteristics

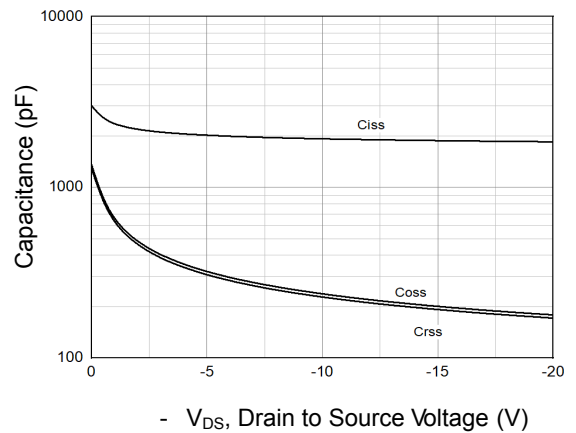
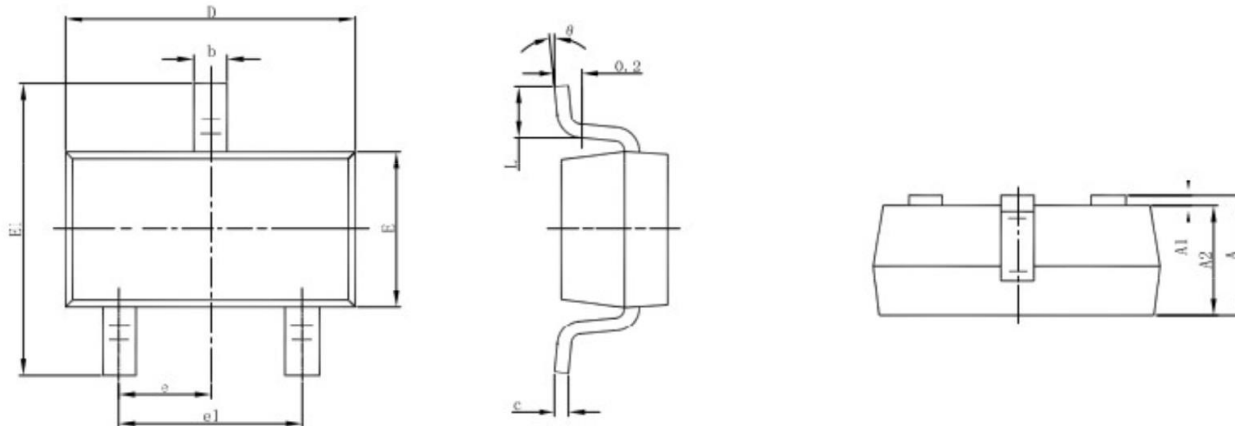

Figure 6. Capacitance Characteristics

Package Outline Dimensions (SOT-23-3L)



Symbol	Dimensions in Millimeters		Dimensions in Inches	
	Min	Max	Min	Max
A	1.050	1.250	0.041	0.049
A1	0.000	0.100	0.000	0.004
A2	1.050	1.150	0.041	0.045
b	0.300	0.500	0.012	0.020
c	0.100	0.200	0.004	0.008
D	2.820	3.020	0.111	0.119
E	1.500	1.700	0.059	0.067
E1	2.650	2.950	0.104	0.116
e	0.950 BSC		0.037 BSC	
e1	1.800	2.000	0.071	0.079
L	0.300	0.600	0.012	0.024
θ4	0°	8°	0°	8°